

USER'S INFORMATION MANUAL

INDEPENDENCE® GAS - FIRED BOILER

WARNING: If the information in this manual is not followed exactly, a fire or explosion may result causing property damage, personal injury or loss of life.

- Do not store or use gasoline or other flammable vapors and liquids in the vicinity of this or any other appliance.

WHAT TO DO IF YOU SMELL GAS

- Do not try to light any appliance.
- Do not touch any electrical switch; do not use any phone in your building.
- Immediately call your gas supplier from a neighbor's phone. Follow the gas supplier's instructions.
- If you cannot reach your gas supplier, call the fire department.
- Installation and service must be performed by a qualified installer, service agency or the gas supplier.

AVERTISSEMENT. Assurez-vous de bien suivre les instructions données dans cette notice pour réduire au minimum le risque d'incendie ou d'explosion ou pour éviter tout dommage matériel, toute blessure ou la mort.

- Ne pas entreposer ni utiliser d'essence ni d'autres vapeurs ou liquides inflammables dans le voisinage de cet appareil ou de tout autre appareil.

QUE FAIRE SI VOUS SENTEZ UNE ODEUR DE GAZ:

- Ne pas tenter d'allumer d'appareils.
- Ne touchez à aucun interrupteur. Ne pas vous servir des téléphones dans le bâtiment où vous vous trouvez.
- Appelez immédiatement votre fournisseur de gaz depuis un voisin. Suivez les instructions du fournisseur.
- Si vous ne pouvez rejoindre le fournisseur de gaz, appelez le service des incendies.
- L'installation et l'entretien doivent être assurés par un installateur ou un service d'entretien qualifié ou par le fournisseur de gaz.



U.S. Boiler Company

The following terms are used throughout this manual to bring attention to the presence of hazards of various risk levels.

WARNING

Indicates a potentially hazardous situation which, if not avoided, could result in death, serious injury or substantial property damage.

CAUTION

Indicates a potentially hazardous situation which, if not avoided, may result in moderate or minor injury or property damage.

Basic Operation

CAUTION

Should overheating occur or the gas supply fail to shut off, do not turn off or disconnect the electrical supply to the pump. Instead, shut off the gas supply at a location external to the appliance.
En cas de surchauffe ou si l'admission de gaz ne peut être coupée, ne pas couper ni débrancher l'alimentation électrique de la pompe. Fermer plutôt le robinet d'admission de gaz à l'extérieur de l'appareil.

Do not use this boiler if any part has been under water. Immediately call a qualified service technician to inspect the boiler and to replace any part of the control system and any gas control which has been under water.

A. General This boiler is equipped with controls for proper operation. All controls must be in proper working order. Contact a qualified service agency to provide annual maintenance as specified in the Installation, Operating and Service Instructions.

WARNING

Service on this boiler should be undertaken only by trained and skilled personnel from a qualified service agency.

1. **Limit** A device which automatically interrupts boiler operation when the steam pressure (or water temperature for water boilers) exceeds the set point.

Steam See Figure 1. Maximum allowable pressure is 15 psi. Steam pressure can be read on the Pressure Gauge.

Water Maximum allowable temperature is 250°F. Water temperature can be read on the Temperature-Pressure Gauge on the left side of boiler.

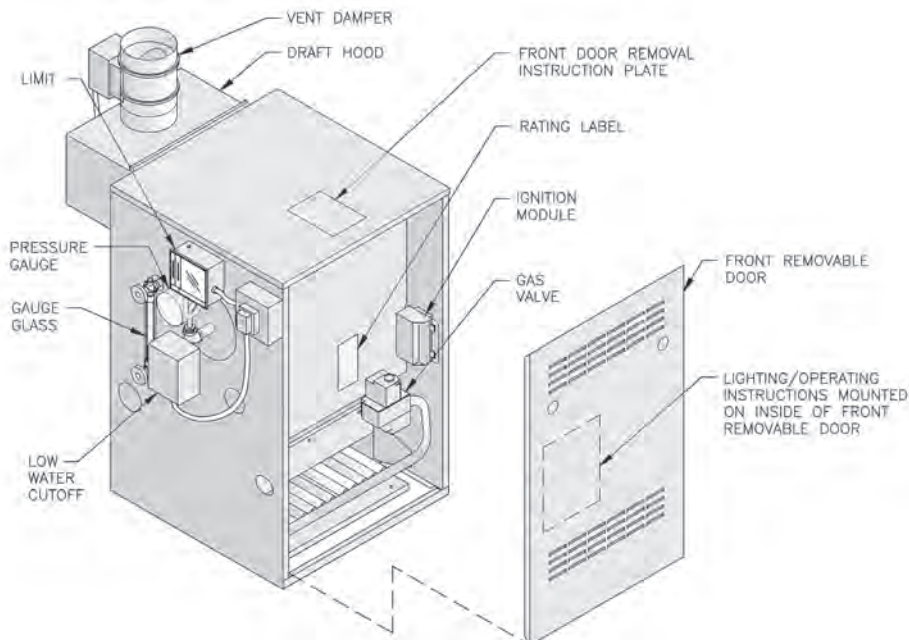

Figure 1: Control Locations

2. **Low Water Cutoff** A device which automatically interrupts boiler operation when the surface of the boiler water falls to the lowest permissible operating level.

Steam (standard equipment). See Figure 1. The lowest permissible operating level is indicated on a plate adjacent to the gauge glass. The low water cutoff automatically resets when water returns to its normal level. Boiler operation resumes with a call for heat.

Water (Required when boiler is installed above radiation. May also be required by local code. Provided by installing contractor). If the control was activated to interrupt boiler operation, do not attempt to place boiler in operation. Contact a qualified service agency.

3. **Blocked Vent Switch** See Figure 8. A device which automatically interrupts boiler operation when excessive vent system blockage occurs. If the control was activated to interrupt boiler operation, do not attempt to place boiler in operation. Contact a qualified service agency.

CAUTION

Do not reset Blocked Vent Switch unless a qualified service agency has determined and corrected the cause of any blockage in the vent system or chimney.

4. **Flame Rollout Switch** See Figure 2. A device which automatically interrupts boiler operation when flames or excessive heat are present in the vestibule. The control is a single use device. If the control was activated to interrupt boiler operation, do not attempt to place boiler in operation. Contact a qualified service agency.

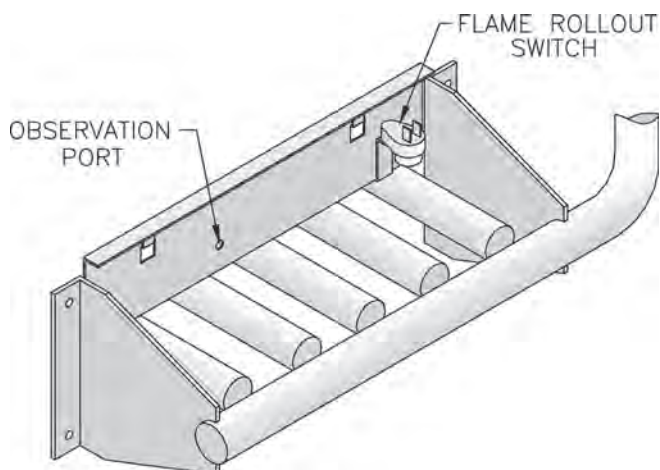

Figure 2: Flame Rollout Switch

5. **Continuous Ignition System (Standing Pilot)** See Figure 1. The Continuous Ignition System consists of:

- a. a combination (VR8200, VR8300 or 7000ERHC) gas valve to regulate gas flow to burners.
- b. a constant burning pilot burner to provide the ignition source for main burners.
- c. a thermocouple to sense pilot burner flame and cause combination gas valve to turn off main burner and pilot burner gas flow should pilot burner flame extinguish.

6. **Intermittent Ignition System** See Figure 1. The Electronic Ignition (EI) System consists of:

- a. an ignition module to initiate, monitor and stop burner operation.
- b. a combination (VR8204 or VR8304) gas valve to regulate gas flow to burners.
- c. a pilot burner to provide the ignition source for main burners.

B. Instructions to place boiler in operation and to turn off boiler are shown on the Lighting or Operating Instruction label posted on the inside of the front removable door. See Figure 3 for front door removal instructions. The Lighting/Operating Instructions are also shown in Figures 4, 5, 6, 7 and 8. The boiler model number is printed on the rating label (see Figure 1).

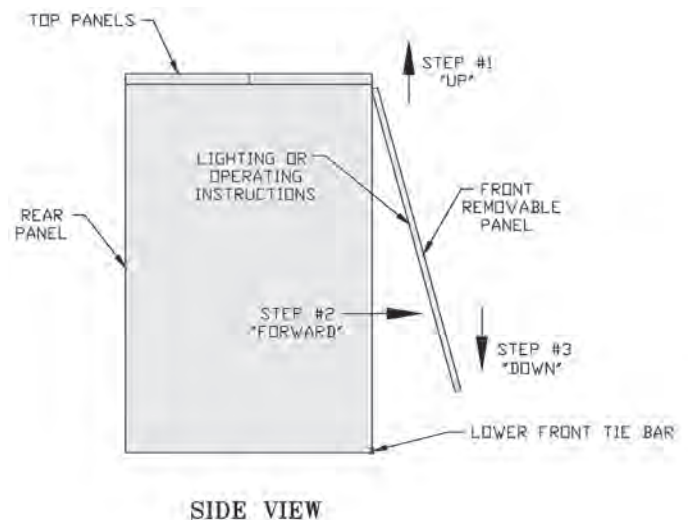

Figure 3: Jacket Front Panel Removal

FOR YOUR SAFETY READ BEFORE LIGHTING

WARNING: If you do not follow these instructions exactly, a fire or explosion may result causing property damage, personal injury, or loss of life.

- A. This appliance has a pilot which must be lighted by hand. When lighting the pilot, follow these instructions exactly.
- B. BEFORE LIGHTING smell all around the appliance for gas. Be sure to smell next to the floor because some gas is heavier than air and will settle on the floor.
- WHAT TO DO IF YOU SMELL GAS**
- Do not try to light any appliance.
 - Do not touch any electric switch; do not use any phone in your building.
 - Immediately call your gas supplier from a neighbor's phone. Follow the gas supplier's instructions.
- C. Use only your hand to push in or turn the gas control knob. Never use tools. If the knob will not push in or turn by hand, don't try to repair it, call a qualified service technician. Force or attempted repair may result in a fire or explosion.
- D. Do not use this appliance if any part has been under water. Immediately call a qualified service technician to inspect the appliance and to replace any part of the control system and any gas control which has been under water.

LIGHTING INSTRUCTIONS

1. STOP! Read the safety information above.
2. Read the lighting instructions all the way through before starting the procedure.
3. If equipped with a vent damper, set the room thermostat to highest setting and wait two (2) minutes for the damper to open.
4. Turn off all electric power to the appliance.
5. Set the room thermostat to lowest setting.
6. Remove front door.
7. Locate the gas control valve at the end of the gas supply pipe going into the boiler. The gas control knob is the blue or brown plastic knob located on top of the gas control valve.
8. Rotate gas control knob clockwise from "ON" position to "OFF" position.
9. Wait five (5) minutes to clear out any gas. Then smell for gas, including near the floor. If you smell gas, STOP! Follow "B" in the safety information above on this label. If you do not smell gas, go to the next step. NOTE: Vent damper must be open during this five (5) minute wait period.
10. Remove the burner access panel located above the burners.
11. Find the pilot by following the aluminum tube from the gas control valve to the pilot located between the steel tube burners.
12. Turn gas control knob counterclockwise to "PILOT" position.
13. Push in red reset button and hold in. Immediately light the pilot with a match. Continue to hold the red reset button for about one (1) minute after the pilot is lit. Release button and it will pop back up. Pilot should remain lit. If it goes out, repeat Steps 8 - 13.
14. Replace burner access panel.
15. Turn gas control knob counterclockwise to "ON" position. Knob can be turned to "ON" only if red reset button is up.
16. Replace front door.
17. Turn on all electric power to the appliance.
18. Set room thermostat to desired setting.

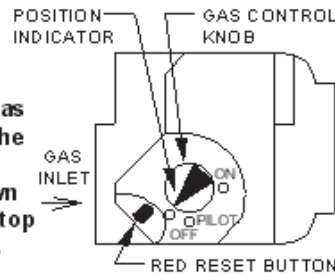
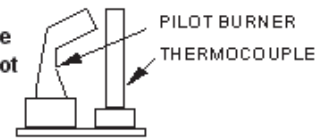

TO TURN OFF GAS TO APPLIANCE

1. Set the thermostat to lowest setting.
2. Turn off all electric power to the appliance if service is to be performed.
3. Remove front door.
4. Turn gas control knob clockwise to "OFF". Do not force.
5. Replace front door.

Figure 4: Lighting Instructions, Continuous Ignition System, VR8200/VR8300 Gas Valves

THIS PAGE LEFT INTENTIONALLY BLANK

FOR YOUR SAFETY READ BEFORE LIGHTING

WARNING: If you do not follow these instructions exactly, a fire or explosion may result causing property damage, personal injury, or loss of life.

A. This appliance has a pilot which must be lighted by hand. When lighting the pilot, follow these instructions exactly.

B. **BEFORE LIGHTING** smell all around the appliance area for gas. Be sure to smell next to the floor because some gas is heavier than air and will settle on the floor.

WHAT TO DO IF YOU SMELL GAS:

- Do not try to light any appliance.
- Do not touch any electric switch; do not use any phone in your building.
- Immediately call your gas supplier from a neighbor's phone. Follow the gas supplier's instructions.

- If you cannot reach your gas supplier, call the fire department.

C. Use only your hand to push in or turn the gas control knob. Never use tools. If the knob will not push in or turn by hand, don't try to repair it, call a qualified service technician. Force or attempted repair may result in a fire or explosion.

D. Do not use this appliance if any part has been under water. Immediately call a qualified service technician to inspect the appliance and to replace any part of the control system and any gas control which has been under water.

LIGHTING INSTRUCTIONS

1. STOP! Read the safety information above on this label.
2. Read the lighting instructions all the way through before starting the procedure.
3. If equipped with vent damper, set the room thermostat to highest setting and wait two (2) minutes for the damper to open.
4. Turn off all electric power to the appliance.
5. Set the room thermostat to lowest setting.
6. Remove front door.

7. Locate the gas control valve at the end of the gas supply pipe going into the boiler. The gas control knob is the gray or brown plastic knob located on top of the gas control valve.

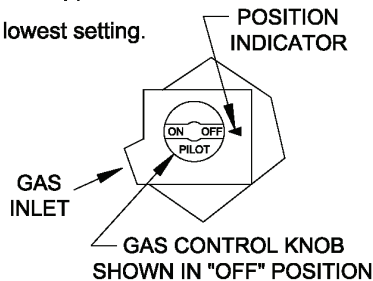

8. Push in gas control knob slightly and turn clockwise to "OFF". NOTE: Knob cannot be turned from "PILOT" to "OFF" unless knob is pushed in slightly. Do not force.
9. Wait five (5) minutes to clear out any gas. Then smell for gas, including near the floor. If you smell gas, STOP! Follow "B" in the safety information above on this label. If you do not smell gas, go to the next step. NOTE: Vent damper must be open during this five (5) minute wait period.

10. Remove burner access panel.

11. Find the pilot by following the aluminum tube from the gas control valve to the pilot located between the steel tube burners.

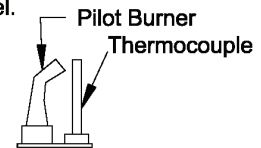

12. Turn gas control knob counterclockwise to "PILOT" position.

13. Push in control knob all the way and hold in. Immediately light the pilot with a match. Continue to hold the control knob for about one (1) minute after the pilot is lit. Release knob and it will pop back up. Pilot should remain lit. If it goes out, repeat steps 8-13.

- If knob does not pop up when released, stop and immediately call your service technician or gas supplier.
- If the pilot will not stay lit after several tries, turn gas control knob to "OFF" and call your service technician or gas supplier.

14. Replace burner access panel.

15. Turn gas control knob counterclockwise to "ON" position.

16. Replace front door.

17. Turn on all electric power to the appliance.

18. Set room thermostat to desired setting.

TO TURN OFF GAS TO APPLIANCE

1. Set the thermostat to the lowest setting.
2. Turn off all electric power to the appliance if service is to be performed.
3. Remove front door.

4. Push in gas control knob slightly and turn clockwise to "OFF". Do not force.
5. Replace front door.

Figure 5: Lighting Instructions, Continuous Ignition System, 7000 ERHC Gas Valve

THIS PAGE LEFT INTENTIONALLY BLANK

FOR YOUR SAFETY READ BEFORE OPERATING

WARNING: If you do not follow these instructions exactly, a fire or explosion may result causing property damage, personal injury, or loss of life.

- A. This appliance is equipped with an ignition device which automatically lights the pilot. Do not try to light the pilot by hand.
- B. **BEFORE OPERATING** smell all around the appliance area for gas. Be sure to smell next to the floor because some gas is heavier than air and will settle on the floor.

WHAT TO DO IF YOU SMELL GAS

- Do not try to light any appliance.
- Do not touch any electric switch; do not use any phone in your building.
- Immediately call your gas supplier from a neighbor's phone. Follow the gas supplier's instructions.

➤ If you cannot reach your gas supplier, call the fire department.

- C. Use only your hand to push in or turn the gas control knob. Never use tools. If the knob will not push in or turn by hand, don't try to repair it, call a qualified service technician. Force or attempted repair may result in a fire or explosion.
- D. Do not use this appliance if any part has been under water. Immediately call a qualified service technician to inspect the appliance and to replace any part of the control system and any gas control which has been under water.

OPERATING INSTRUCTIONS

1. **STOP!** Read the safety information above on this label.
2. Set the thermostat to lowest setting.
3. Turn off all electric power to the appliance.
4. This appliance is equipped with an ignition device which automatically lights the pilot. Do not try to light the pilot by hand.
5. Remove front door.
6. Locate the gas control valve at the end of the gas supply pipe going into the boiler. The gas control knob is the brown or blue plastic knob located on top of the gas control valve.

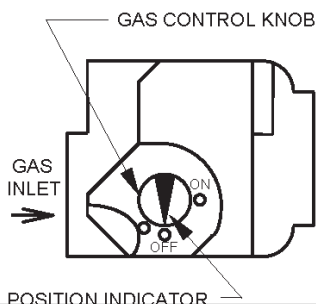

7. Rotate gas control knob clockwise from "ON" position to "OFF". Make sure knob rests against stop.
8. Wait five (5) minutes to clear out any gas. Then smell for gas, including near the floor. If you smell gas, **STOP!** Follow "B" in the safety information above on this label. If you do not smell gas, go to the next step.
9. Rotate gas control knob counterclockwise from "OFF" to "ON". Make sure knob rest against stop. Do not force.
10. Replace front door.
11. Turn on all electric power to the appliance.
12. Set thermostat to desired setting.
13. If the appliance will not operate, follow the instructions "TO TURN OFF GAS TO APPLIANCE" and call your service technician or gas supplier.

TO TURN OFF GAS TO APPLIANCE

1. Set the thermostat to lowest setting.
2. Turn off all electric power to the appliance if service is to be performed.
3. Remove front door.
4. Rotate gas control knob clockwise from "ON" position to "OFF". Make sure knob rests against stop.
5. Replace front door.

Figure 6: Operating Instructions, Intermittent Ignition System, VR8204 and VR8304 (except Model _IN12_ _ I) Gas Valves

FOR YOUR SAFETY READ BEFORE OPERATING

WARNING: If you do not follow these instructions exactly, a fire or explosion may result causing property damage, personal injury, or loss of life.

A. This appliance is equipped with an ignition device which automatically lights the pilot. Do not try to light the pilot by hand.

B. BEFORE OPERATING smell all around the appliance area for gas. Be sure to smell next to the floor because some gas is heavier than air and will settle on the floor.

WHAT TO DO IF YOU SMELL GAS

- Do not try to light any appliance.
- Do not touch any electric switch; do not use any phone in your building.
- Immediately call your gas supplier from a neighbor's phone. Follow the gas supplier's instructions.

➤ If you cannot reach your gas supplier, call the fire department.

C. Use only your hand to push in or turn the gas control knob. Never use tools. If the knob will not push in or turn by hand, don't try to repair it, call a qualified service technician. Force or attempted repair may result in a fire or explosion.

D. Do not use this appliance if any part has been under water. Immediately call a qualified service technician to inspect the appliance and to replace any part of the control system and any gas control which has been under water.

OPERATING INSTRUCTIONS

1. STOP! Read the safety information above on this label.

2. Set the thermostat to lowest setting.

3. Turn off all electric power to the appliance.

4. This appliance is equipped with an ignition device which automatically lights the pilot. Do not try to light the pilot by hand.

5. Remove front door.

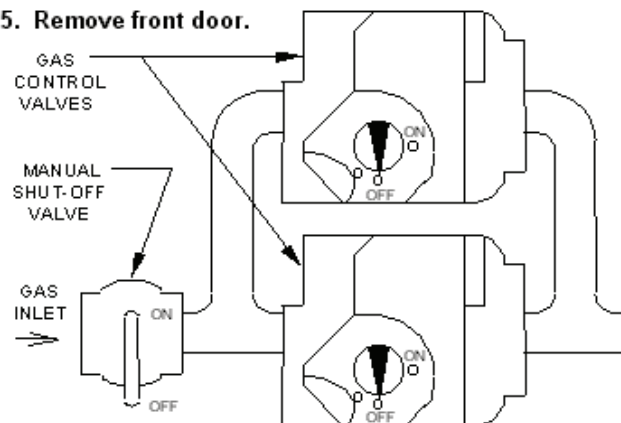

6. Locate manual shut-off valve and both gas control valves at the end of the gas supply pipe going into the boiler.

7. Rotate handle on manual shut-off valve clockwise from "ON" position to "OFF".

8. Rotate gas control knob on BOTH gas valves clockwise from "ON" position to "OFF".

9. Wait five (5) minutes to clear out any gas. Then smell for gas, including near the floor. If you smell gas, STOP! Follow "B" in the safety information above on this label. If you do not smell gas, go to the next step.

10. Rotate gas control knob on BOTH gas valves counterclockwise from "OFF" position to "ON". Do not force.

11. Rotate handle on manual shut-off valve counterclockwise from "OFF" position to "ON". Do not force.

12. Replace front door.

13. Turn on all electric power to the appliance.

14. Set thermostat to desired setting.

15. If the appliance will not operate, follow the instructions "TO TURN OFF GAS TO APPLIANCE" and call your service technician or gas supplier.

TO TURN OFF GAS TO APPLIANCE

1. Set the thermostat to lowest setting.

2. Turn off all electric power to the appliance if service is to be performed.

3. Remove front door.

4. Rotate handle on manual shut-off valve clockwise from "ON" position to "OFF".

5. Rotate gas control knob on BOTH gas valves clockwise from "ON" position to "OFF".

6. Replace front door.

(DUAL VR8304)

WARNING

Service on this boiler should be undertaken only by trained and skilled personnel from a qualified service agency. Inspections should be performed at intervals specified in Installation, Operating and Service Instructions and this manual. Maintain manuals in a legible condition.

Keep boiler area clear and free of combustible materials, gasoline and other flammable vapors and liquids.

Do not place any obstructions in boiler room that will hinder flow of combustion and ventilation air.

A. General Housekeeping (Continuous)

1. Keep boiler area clear and free of combustible materials and obstructions to the free flow of combustion and ventilation air to the boiler.
2. Do not store or use gasoline or other flammable vapors or liquids in the vicinity of the boiler or any other appliance.
3. Do not store or use sources of hydrocarbons in the vicinity of the boiler. Sources of hydrocarbons include bleaches, cleaners, chemicals, sprays, paint removers, fabric softeners, cat litter and refrigerants.

B. Flush Low Water Cutoff (Weekly, or more frequently if needed). Applicable to McDonnell & Miller 67 float low water cutoff only. Follow instructions on Blow-Down Card affixed to Jacket adjacent to low water cutoff.

C. Inspect Vent System (Monthly). See Figure 8. Follow instructions TO TURN OFF GAS TO APPLIANCE (see Figure 4, 5, 6 or 7) and contact a qualified service agency if any of the following conditions are found:

1. Collapsed vent pipe

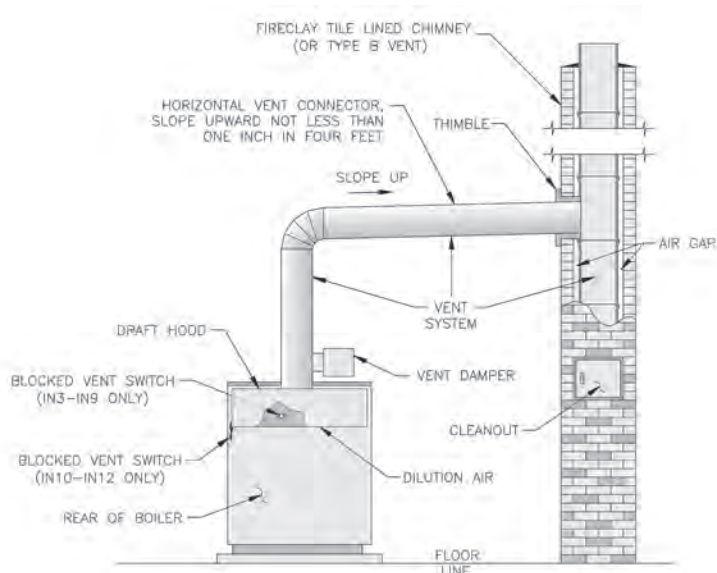

Figure 8: Typical Vent System Installation

2. Disconnected or loose joints
3. Sags in horizontal runs
4. Corrosion or other deterioration
5. Broken or loose supports
6. Blocked vent switch not attached to draft hood.

D. Inspect Pilot and Main Burner Flame (Monthly).

1. Adjust thermostat to lowest setting.
2. Remove front removable panel. See Figure 3.
3. Locate Pilot Observation Port. See Figure 2.
4. Check pilot burner flame.
 - a. Continuous Ignition (Standing Pilot), Models IN3_C through IN7_C. See Figure 9. Pilot burner produces a single flame. The flame should be steady, medium hard blue enveloping 3/8 to 1/2 inch of thermocouple. If flame is yellow and lazy, follow instructions TO TURN OFF GAS TO APPLIANCE (see Figure 4) and contact a qualified service agency.

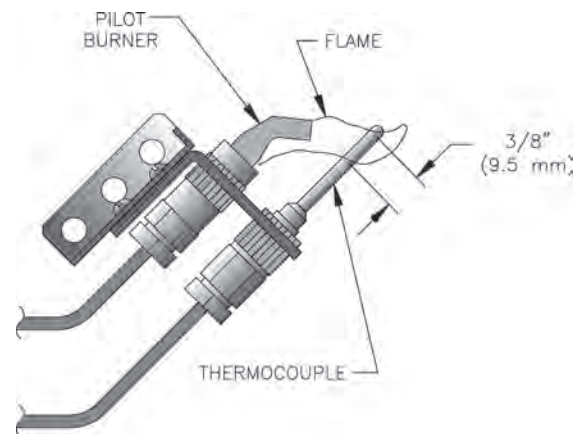

Figure 9: Pilot Burner Flame, Continuous Ignition System, Honeywell Q350 Pilot

- b. Continuous Ignition (Standing Pilot), Models IN8_C through IN12_C. See Figure 10. Pilot burner produces three (3) flames. The center flame should be steady, medium hard blue enveloping 3/8 to 1/2 inch of thermocouple. If flames are yellow and lazy, follow instructions TO TURN OFF GAS TO APPLIANCE (see Figure 4 for Models IN8_C and IN9_C or

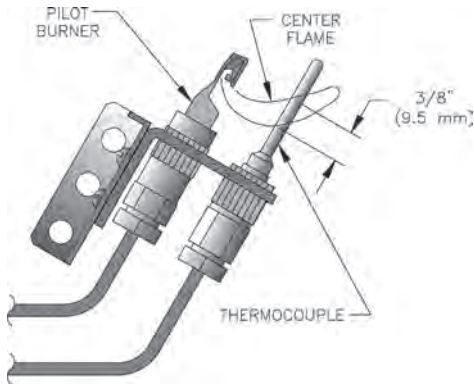

Figure 10: Pilot Burner Flame, Continuous Ignition System, Honeywell Q327 Pilot

Figure 5 for Models IN10_C through IN12_C) and contact a qualified service agency.

- c. Intermittent Ignition (EI), Models IN3_I through IN12_I. See Figure 11. The pilot burner produces three (3) flames. The center flame should be steady, medium hard blue enveloping 3/8 to 1/2 inch of sensing probe. If flames are yellow and lazy, follow instructions TO TURN OFF GAS TO APPLIANCE (see Figure 6 for Models IN3_I through IN11_I or Figure 7 for Model IN12_I) and contact a qualified service agency.

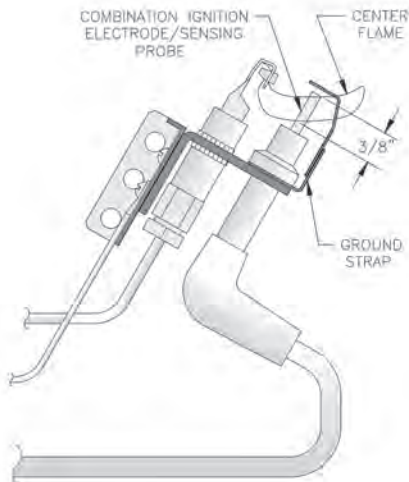

Figure 11: Pilot Burner Flame, Intermittent Ignition System (EI), Honeywell Q348 Pilot

- 5. Adjust thermostat to highest setting.
- 6. Check main burner flames. See Figure 12 or 13. Flame should have clearly defined inner cones with no yellow tipping. Orange-yellow streaks caused by dust should not be confused with true yellow tipping. If yellow flames are observed, follow instructions TO TURN OFF GAS TO APPLIANCE (see Figure 4, 5, 6 or 7) and contact a qualified service agency.
- 7. Adjust thermostat to normal setting.

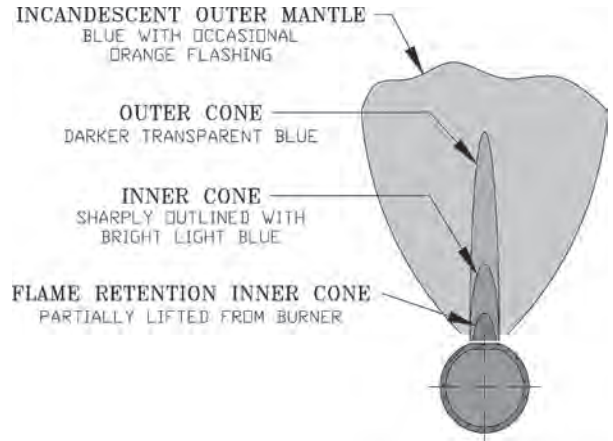

Figure 12: 1 Inch Main Burner Flame

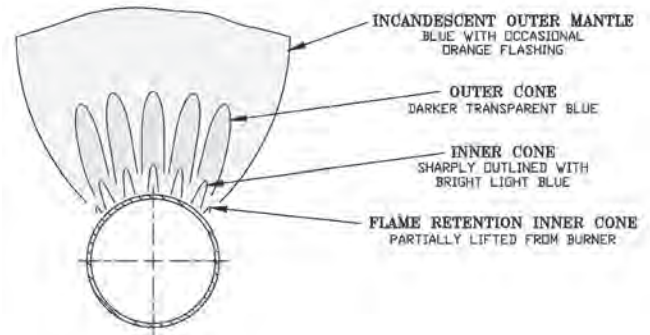

Figure 13: 40mm Main Burner Flame

- E. Schedule Inspection by Qualified Service Agency (Annual or at Beginning of Heating Season).** For continued safe operation a qualified service agency must provide a more detailed inspection of burners, heat exchanger and vent system, and provide maintenance as specified in Installation, Operating and Service Instructions.

Important Product Safety Information **Refractory Ceramic Fiber Product**

Warning:

The Repair Parts list designates parts that contain refractory ceramic fibers (RCF). RCF has been classified as a possible human carcinogen. When exposed to temperatures about 1805°F, such as during direct flame contact, RCF changes into crystalline silica, a known carcinogen. When disturbed as a result of servicing or repair, these substances become airborne and, if inhaled, may be hazardous to your health.

AVOID Breathing Fiber Particulates and Dust

Precautionary Measures:

Do not remove or replace RCF parts or attempt any service or repair work involving RCF without wearing the following protective gear:

1. A National Institute for Occupational Safety and Health (NIOSH) approved respirator
 2. Long sleeved, loose fitting clothing
 3. Gloves
 4. Eye Protection
- Take steps to assure adequate ventilation.
 - Wash all exposed body areas gently with soap and water after contact.
 - Wash work clothes separately from other laundry and rinse washing machine after use to avoid contaminating other clothes.
 - Discard used RCF components by sealing in an airtight plastic bag. RCF and crystalline silica are not classified as hazardous wastes in the United States and Canada.

First Aid Procedures:

- If contact with eyes: Flush with water for at least 15 minutes. Seek immediate medical attention if irritation persists.
- If contact with skin: Wash affected area gently with soap and water. Seek immediate medical attention if irritation persists.
- If breathing difficulty develops: Leave the area and move to a location with clean fresh air. Seek immediate medical attention if breathing difficulties persist.
- Ingestion: Do not induce vomiting. Drink plenty of water. Seek immediate medical attention.

CAUTION

This boiler contains controls which may cause the boiler to shut down and not restart without service. If damage due to frozen pipes is a possibility, the heating system should not be left unattended in cold weather; or appropriate safeguards and alarms should be installed on the heating system to prevent damage if the boiler is inoperative.

All Independence® Series Repair Parts may be obtained through your local Burnham product distributor. Should you require assistance in locating a Burnham product distributor in your area, or have questions regarding the availability of Burnham brand products or repair parts, please contact U.S. Boiler Company Customer Service at (717) 481-8400 or Fax (717) 481-8408.