

# SQ, SQE, SQE-NE, CU 321

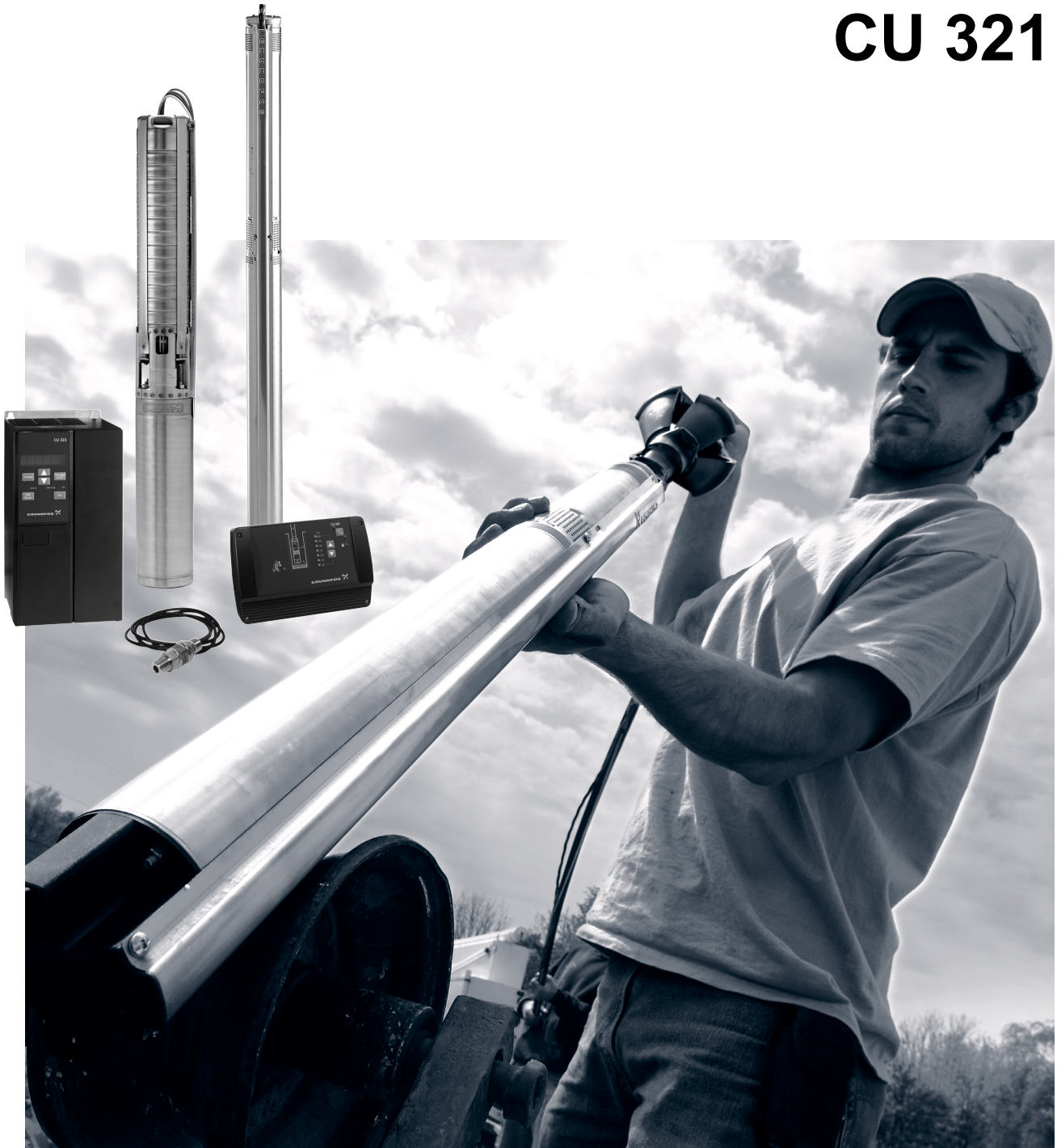

# Contents

## Product introduction

Introduction	4
Features and benefits	4
Identification	6

## Applications

SQ with pressure switch and pressure tank	7
Constant-pressure control with CU 301 - residential water supply	8
Constant-pressure control with CU 301 - irrigation	9
Maintaining a constant water table	10
Emptying or filling a tank	11
Pumping from one tank to another	12
Setting of operating parameters	13
SQE with manual speed control	14

## Product overview

Performance range	15
-------------------	----

## Installation

Installation	16
--------------	----

## Sizing and selection

System sizing guide	17
---------------------	----

## Cable sizing

SQ, SQE, SQE-NE cable sizing chart	18
------------------------------------	----

## Curve charts

5 SQ, SQE	19
10 SQ, SQE	20
15 SQ, SQE	21
22 SQ, SQE	22
30 SQ, SQE	23
10 SQE-NE	24
22 SQE, SQE-NE	25

## Technical data

Electrical data	26
Operating conditions	26
Storage conditions	26
SQ, SQE motor data	27
SQ, SQE and SQE-NE dimensions and weights	28
Materials of construction	29
Material specification	30

## Control units

CU 301	31
R100 menu structure for CU 301 control unit	32
R100 menus for CU 301	33
CU 300	34
R100 menu structure for the CU 300	35
R100 menus for CU 300	36
Examples of R100 displays	37

## CU 321 variable frequency drive

Features	38
Applications	38
Components	38
Sizing	38
Performance curves - CU 321 variable speed	39

## Accessories

CU 321 variable frequency drive	41
CU 301 Constant Pressure System	41
CU 300 Status Box & R100	41
SQ, SQE flow sleeves	41

## Further product documentation

WebCAPS	42
WinCAPS	43

- It is our mission - the basis of our existence - to successfully develop, produce and sell high-quality pumps and pumping systems world-wide, contributing to a better quality of life and a healthy environment



Bjerringbro, Denmark



Fresno, California



Olathe, Kansas



Monterrey, Mexico



Allentown, Pennsylvania



Oakville, Ontario

- One of the 3 largest pump companies in the world
- The second largest manufacturer of submersible motors in the world
- World headquarters in Denmark
- North American headquarters in Kansas City - Manufacturing in Fresno, California
- 80 companies in 45 countries
- More than 16 million motors and pumps produced annually worldwide
- North American companies operating in USA, Canada and Mexico
- Continuous reinvestment in growth and development enables the company to **BE** responsible, **THINK** ahead, and **INNOVATE**

## Introduction

### 3-inch SQ, SQE submersible well pumps for 3-inch and larger wells

SQ, SQE pumps are suitable for both continuous and intermittent operation for a variety of applications:

- Domestic water supply
- light commercial
- irrigation
- tank applications.

## Features and benefits

SQ, SQE pumps offer these features:

- Dry-run protection
- high efficiency pump and motor
- protection against up-thrust
- soft-start
- over-voltage and under-voltage protection
- over-temperature protection
- high starting torque.

Additionally, SQE pumps offer these advantages:

- Constant pressure control
- variable speed
- electronic control and communication.

### SQ, SQE innovative motor technology

SQ, SQE pumps feature an innovative motor design incorporating permanent-magnet technology. By combining permanent-magnet motors and a Grundfos micro-frequency converter, we are able to deliver unmatched performance and the ability to control and communicate with the pump in ways never before possible. A few of the features that result from this combined technology are Constant Pressure Control, Soft-Start, and Integrated Dry-Run Protection, but these are just a few of the features these pumps offer.

SQ pump models operate at a constant speed much like today's conventional pumps. The difference is that SQ delivers the benefits of an electronically controlled permanent-magnet motor that cannot be achieved with a conventional induction motor.

SQ pumps are available for single-phase power; a simple 2-wire design makes installation easy.

SQE pumps are equipped with a Grundfos "Smart Motor." Like the SQ models, SQ pumps have a high efficiency permanent-magnet motor — but we add the ability to communicate.

The "Smart Motor" communicates via the CU301 status box through the power leads.

It is not necessary to run any additional wires down the well. Communication with the pump provides Constant Pressure Control and the highly useful ability to change the pump performance while the pump is installed in the well. Like the SQ motor, this is also a 2-wire motor designed for single-phase operation.

### Dry-running protection

The pumps are protected against dry running. A value of  $P_{\text{cut-out}}$  ensures cut-out of the pump in case of lack of water in the borehole thus preventing a burnout of the motor.

$P_{\text{cut-out}}$  is factory-set both for the SQ and SQE, SQE-NE pumps.

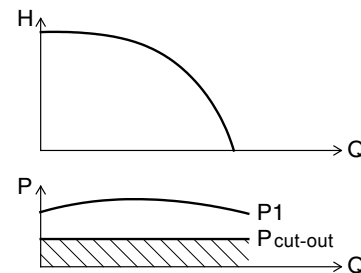

Fig. 1  $P_{\text{cut-out}}$  curve

### High pump efficiency

The hydraulic pump components are polyamide reinforced with 30 % glass fiber. The hydraulic design provides for high pump efficiency resulting in low energy consumption and therefore low energy costs.

TM01 2751 2298

## High motor efficiency

The motors are based on a permanent magnet rotor (PM motor) featuring high efficiency within a wide load range.

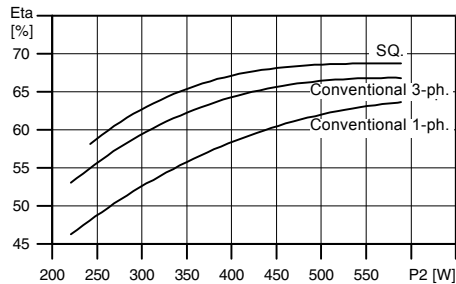

**Fig. 2** Efficiency curves of Grundfos SQ motor versus conventional motors

## Wear resistance

The pump design features "floating" impellers (not fastened to the shaft). Each impeller has its own tungsten carbide/ceramic bearing. The construction and materials ensure high wear resistance to sand for long product life.



**Fig. 3** Example of Grundfos floating impeller

## Protection against upthrust

Starting up a pump with a very low counter pressure involves the risk of the entire impeller stack being lifted, also called upthrust. Upthrust may cause breakdown of both pump and motor.

SQ, SQE, SQE-NE motors are fitted with a top bearing protecting both pump and motor against upthrust, thus preventing breakdown during the critical start-up phase.

## Excellent starting capabilities

The integrated electronic unit of the motor features soft starting. Soft start reduces the starting current and thus gives the pump a smooth and steady acceleration.

The soft starter minimizes the risk of wear on the pump and prevents overloading of the mains during start-up.

The excellent starting capabilities are a result of the high locked-rotor torque of the permanent magnet motor together with the few pump stages. The high starting reliability also applies in case of low voltage supply.

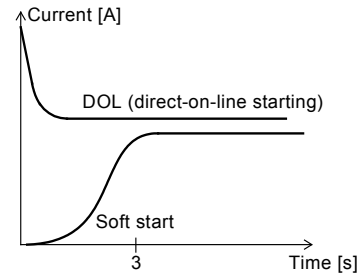

**Fig. 4** Soft-start feature

## Overvoltage and undervoltage protection

Overvoltage and undervoltage may occur in case of unstable voltage supply.

The integrated protection of all motors prevents damage to the motor in case the voltage moves outside the permissible voltage range.

The pump will cut out if the voltage falls below 150 V or rises above 315 V. The motor is automatically cut in again when the voltage again falls within the permissible voltage range. Therefore no extra protection relay is needed.

## Overload protection

Exposure of the pump to heavy load causes the current consumption to rise. The motor will automatically compensate for this by reducing the speed to 3000 rpm. Further overload will lead to stop.

If the rotor is being prevented from rotating, this will automatically be detected and the power supply will be cut out. Consequently, no extra motor protection is needed.

## Overtemperature protection

A permanent magnet motor gives off very little heat to its surroundings. In combination with an efficient internal circulation system leading the heat away from the rotor, stator and bearings, this ensures optimum operating conditions for the motor.

As an extra protection, the electronic unit has a built-in temperature sensor. When the temperature rises too high, the motor is cut out; when the temperature has dropped, the motor is automatically cut in again.

## Reliability

The motors are built for high reliability and feature:

- Tungsten carbide / ceramic bearings
- thrust bearings protecting against downthrust
- product life time equal to conventional AC motors.

## Variable speed

The SQE motor enables continuously variable speed control from 3,000 to 10,700 rpm. The pump can be set to operate in any duty point in the range between the 3,000 and 10,700 rpm performance curves of the pump. Consequently, the pump performance can be adapted to any specific requirement.

The variable speed control facility requires the use of the CU 300 or CU 301 control unit.

For the calculation of pump speed, the program "SQE Speed Calculation" is available on CD-ROM as an accessory.

## Identification

### Type key example SQ, SQE, SQE-NE

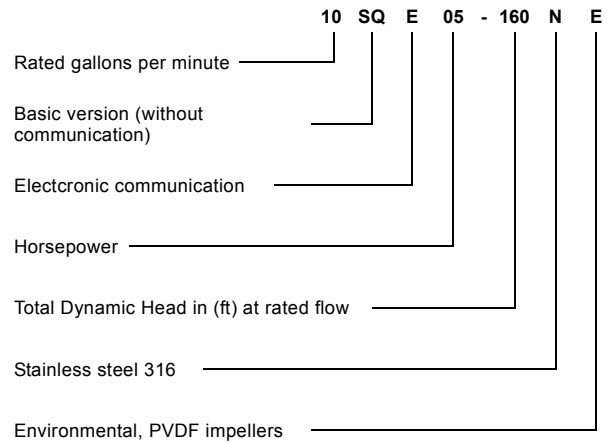

## SQ with pressure switch and pressure tank

SQ is ideally suited for domestic water supply in single-family dwellings or summer homes which are not connected to municipal waterworks. SQ is easy to install and operate.

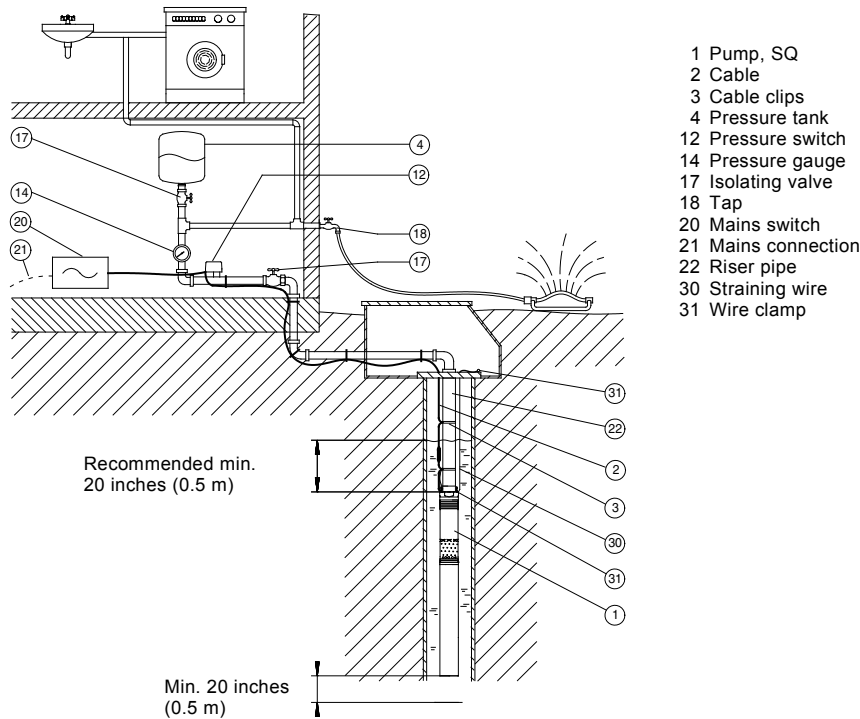

TM01 2447 1798

Fig. 5 Application example: SQ with pressure switch and pressure tank

## SQ with pressure switch and pressure tank

Pos.	Part	Type	No. of units	Product number	Unit price	Total price
1	Pump	SQ				
2	Cable					
3	Cable clips					
4	Pressure tank					
12	Pressure switch					
14	Pressure gauge					
20	Mains switch					
30	Straining wire					
31	Wire clamp					

## Constant-pressure control with CU 301 - residential water supply

### Features and benefits

The system maintains a constant pressure within the maximum pump performance in spite of a varying water consumption.

The pressure is registered by the pressure sensor and transmitted to the CU 301. The CU 301 adjusts the pump performance accordingly.

### Function

When a tap is opened the pressure in the tank will start to drop. At a flow lower than approximately 1 gpm (0.18 m<sup>3</sup>/h), the pressure will drop slowly.

When the pressure in the tank is 7 psi (0.5 bar) below setpoint, the pump will start. The pump will run until the pressure is 7 psi (0.5 bar) above setpoint. This way of operation is called on/off operation.

At a flow higher than approximately 1 gpm (0.18 m<sup>3</sup>/h), the pressure will drop quickly and the pump will start immediately and maintain a constant pressure.

During operation, the CU 301 will regulate the pump speed to maintain a constant pressure. If there is no consumption, the pump will boost the pressure to 7 psi (0.5 bar) above setpoint and stop after a few seconds.

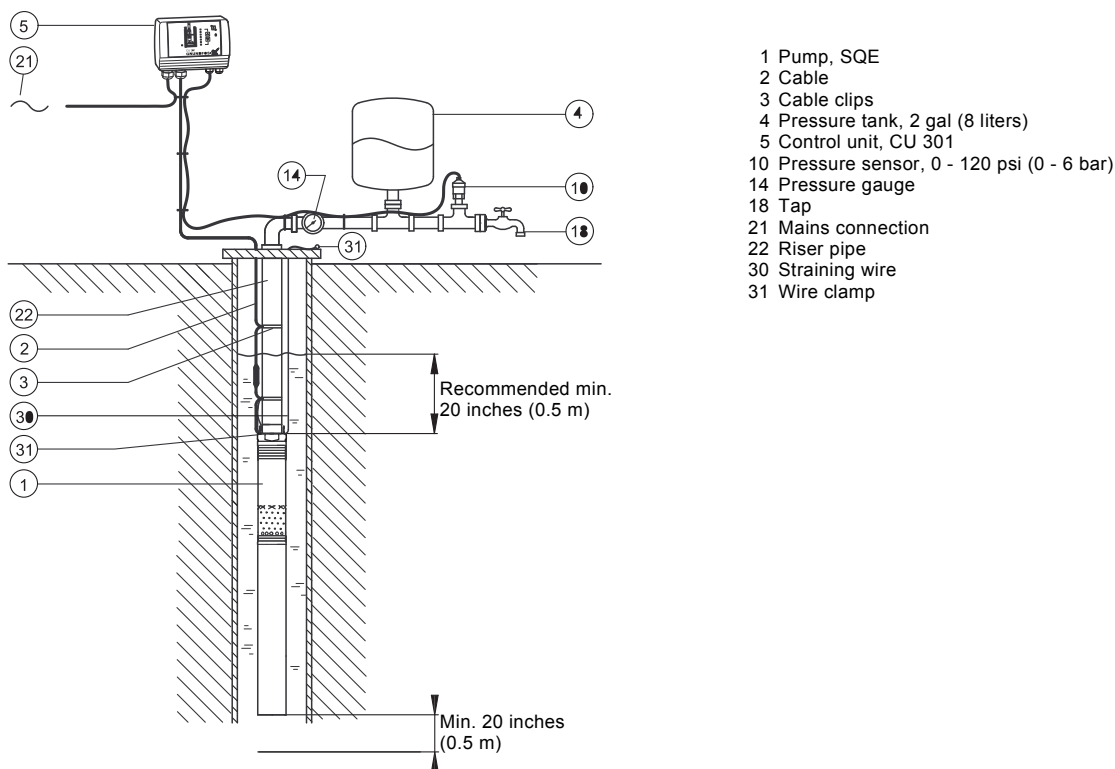

Fig. 6 Application example: Constant-pressure control with CU 301 - residential water supply

TM03 3429 0406

## Constant-pressure control with CU 301 - residential water supply

Pos.	Part	Type	No. of units	Product number	Unit price	Total price
1	Pump	SQE				
2	Cable					
3	Cable clips					
4	Pressure tank	2 gal (8 liters)				
5	Control unit	CU 301				
10	Pressure sensor	0 - 120 psi (0 - 6 bar)				
14	Pressure gauge					
30	Straining wire					
31	Wire clamp					

## Constant-pressure control with CU 301 - irrigation

### Features and benefits

The system maintains a constant pressure within the maximum pump performance in spite of a varying water consumption.

The pressure is registered by means of the pressure sensor and transmitted to the CU 301. The CU 301 adjusts the pump performance accordingly.

### Function

When the sprinkler system is started, the pressure in the tank will start to drop.

At a flow lower than approximately 1 gpm (0.18 m<sup>3</sup>/h),

the pressure will drop slowly. When the pressure in the tank is 7 psi (0.5 bar) below setpoint, the pump will start. The pump will run until the pressure is 7 psi (0.5 bar) above setpoint. This way of operation is called on/off operation.

At a flow higher than approximately 1 gpm (0.18 m<sup>3</sup>/h), the pressure will drop quickly and the pump will start immediately and maintain a constant pressure.

During operation, the CU 301 will regulate the pump speed to maintain a constant pressure. If there is no consumption, the pump will boost the pressure to 7 psi (0.5 bar) above setpoint and stop after a few seconds.

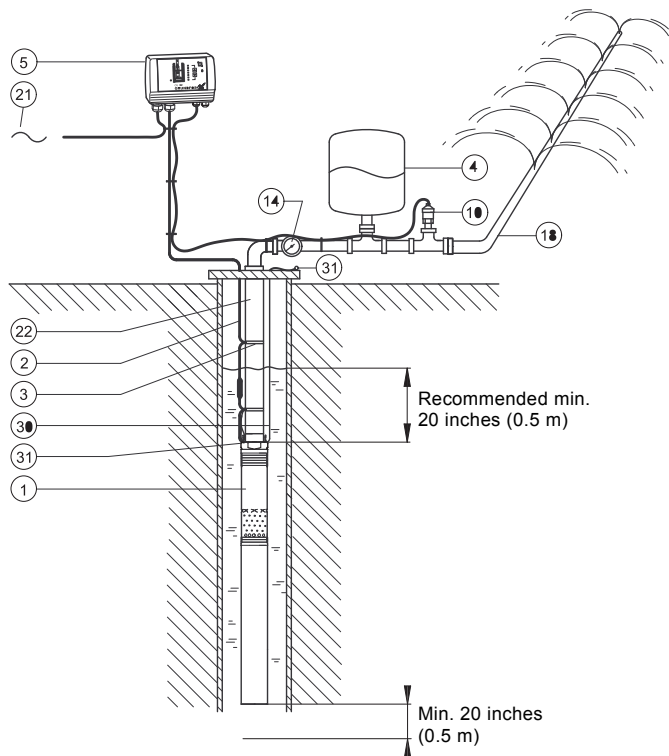

- 1 Pump, SQE
- 2 Cable
- 3 Cable clips
- 4 Pressure tank 2 gal (8 liter)
- 5 Control unit, CU 301
- 10 Pressure sensor, 0 - 120 psi (0-6 bar)
- 14 Pressure gauge
- 18 Sprinkler system
- 21 Mains connection
- 22 Riser pipe
- 30 Straining wire
- 31 Wire clamp

Fig. 7 Application example: Constant-pressure control with CU 301 - irrigation

TM03 3428 0406

## Constant-pressure control with CU 301 - irrigation

Pos.	Part	Type	No. of units	Product number	Unit price	Total price
1	Pump	SQE				
2	Cable					
3	Cable clips					
4	Pressure tank	2 gal (8 liter)				
5	Control unit	CU 301				
10	Pressure sensor	0 - 120 psi (0 - 6 bar)				
14	Pressure gauge					
30	Straining wire					
31	Wire clamp					

## Maintaining a constant water table

### Functioning and benefits

A constant water table can be maintained by adjusting pump performance. It may be important to maintain a constant water table, e.g. in connection with keeping out the groundwater on a building site or water remediation projects.

The example shows how to maintain a constant water table by adjusting pump performance.

### Sensors

Level	Description	Reaction
<b>Level sensor (pos. 11)</b>		
Warning (max.)	Too high water level. Possible cause: Insufficient pump capacity.	Alarm relay operates.
Desired level	The water level which should be maintained.	
Warning (min.)	Too low water level. Possible cause: Too high pump capacity.	Alarm relay operates.

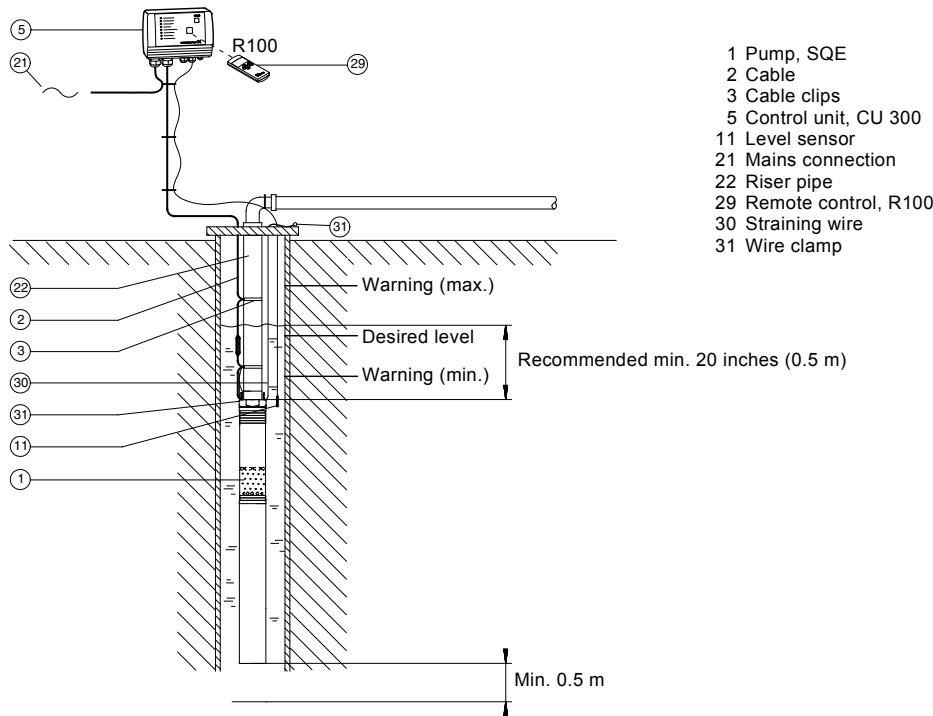

Fig. 8 Application example: Maintaining a constant water table

TMO1 2459 4801

## Maintaining a constant water table

Pos.	Part	Type	No. of units	Product number	Unit price	Total price
1	Pump	SQE				
2	Cable					
3	Cable clips					
5	Control unit	CU 300				
11	Level sensor					
29	Remote control	R100				
30	Straining wire					
31	Wire clamp					

## Emptying or filling a tank

The SQE pump with CU 300 is ideal for emptying or filling a tank.

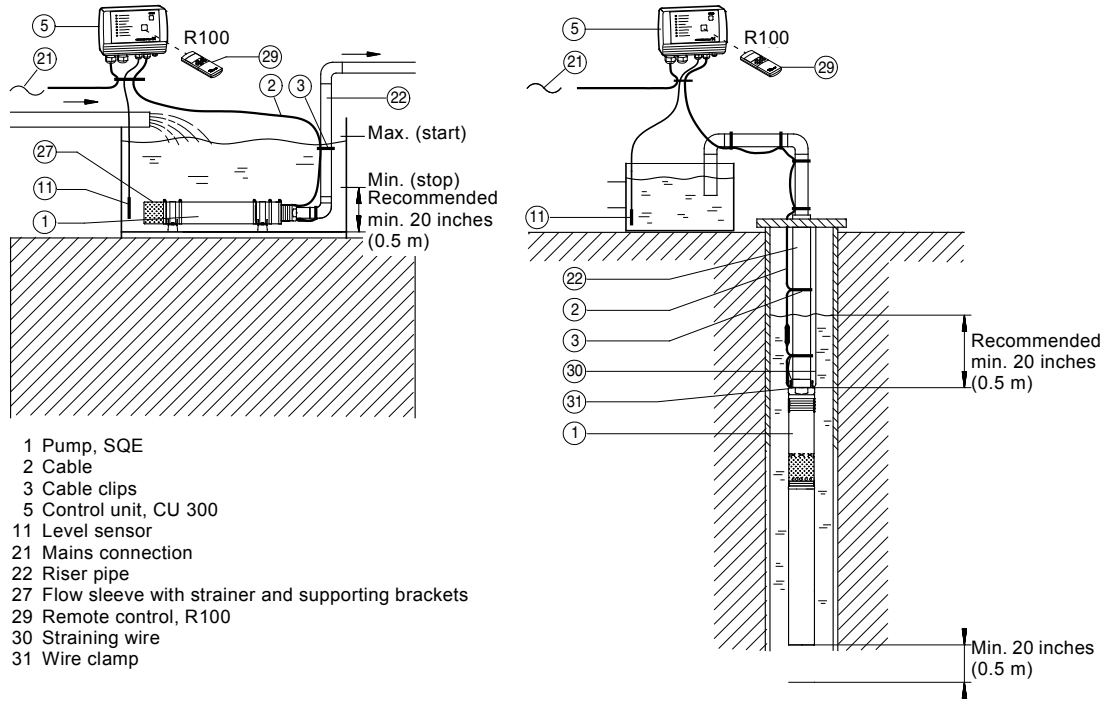

Fig. 9 Application example: Emptying or filling a tank

## Emptying or filling a tank

Pos.	Part	Type	No. of units	Product number	Unit price	Total price
1	Pump	SQE				
2	Cable					
3	Cable clips					
5	Control unit	CU 300				
11	Level sensor					
22	Riser pipe					
27	Flow sleeve with strainer and supporting brackets					
29	Remote control	R100				
30	Straining wire					
31	Wire clamp					

## Pumping from one tank to another

### Functioning and benefits

The SQE pump is ideal for pumping water from one tank to another.

### Sensors

Level	Description	Light indication on CU 300
<b>Level sensor (pos. 11, tank at top)</b>		
Max. (stop)	When the water has reached this level, the pump stops.	Green indicator light in on/off button is flashing.
Min. (start)	When the water has dropped to this level, the pump starts.	Green indicator light in on/off button is permanently on.
<b>Level sensor (pos. 11, tank at bottom)</b>		
Max. (start)	When the water has reached this level, the pump starts.	Green indicator light in on/off button is on.
Min. (stop)	When the water has dropped to this level, the pump stops.	Green indicator light in on/off button is flashing.

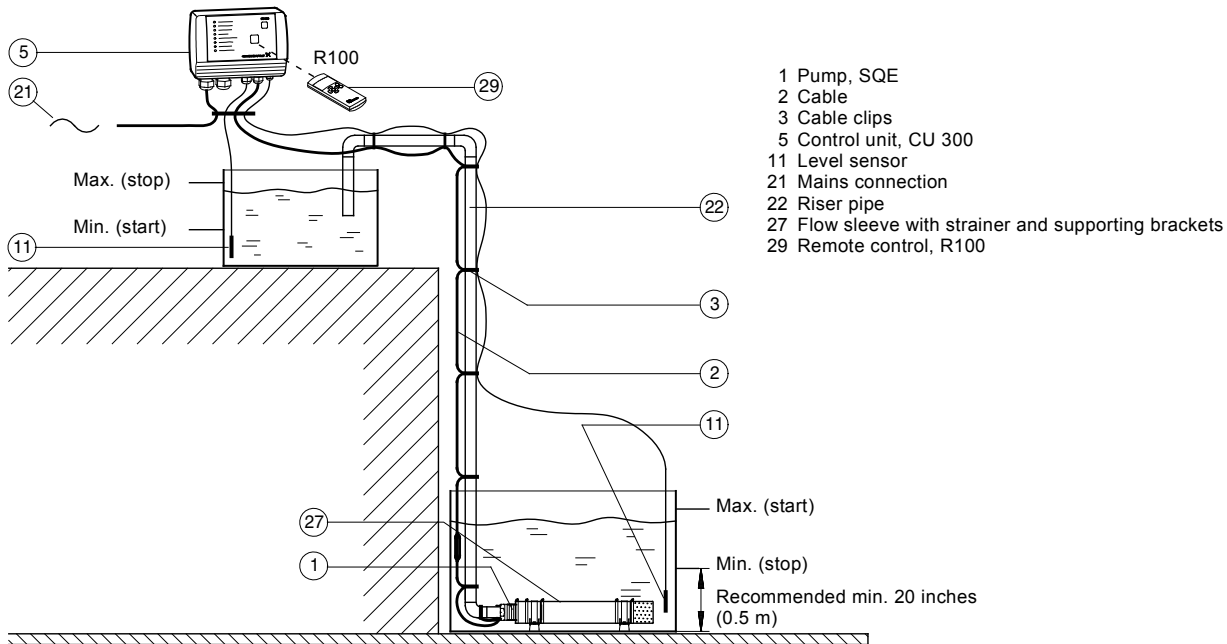

Fig. 10 Application example: Pumping from one tank to another

TM01 2454 4801

## Pumping from one tank to another

Pos.	Part	Type	No. of units	Product number	Unit price	Total price
1	Pump	SQE				
2	Cable					
3	Cable clips					
5	Control unit	CU 300				
11	Level sensor					
27	Flow sleeve with strainer and supporting brackets					
29	Remote control	R100				

## Setting of operating parameters

Using the R100 and the CU 300 enables change of the motor speed and thereby setting of the pump to a specific performance.

The software program "SQE Speed Calculation" has been developed for the calculation of the speed in order to obtain the required flow rate and head.

## Dry-running protection

The value  $P_{\text{cut-out}}$ , ensuring dry-running protection, is factory-set for the SQE pump.

If the speed of the SQE pump is reduced by more than 1000 rpm, the  $P_{\text{cut-out}}$  value must be readjusted by means of the CU 300 and R100.

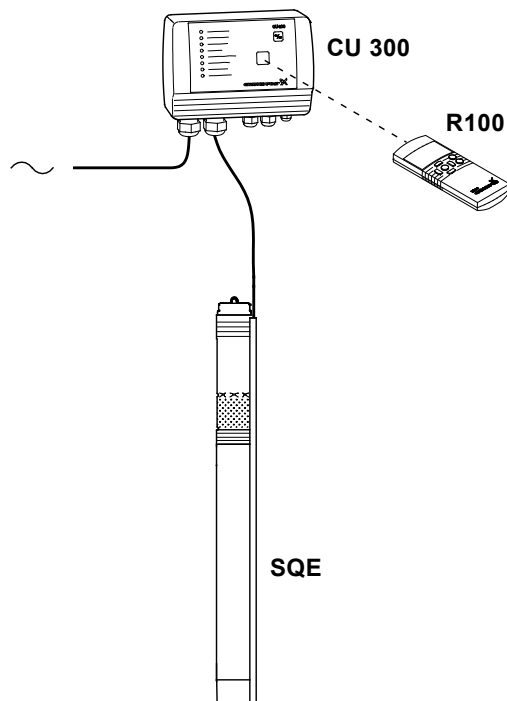

**Note:** The SQE pump must not be started until the pump has been completely submerged below the water table. However, the change of the motor speed can be made even if the pump is not submerged.

Fig. 11 Application example: Workshop setting of operating parameters

TMO1 8650 4801

## Setting of operating parameters

Part	Type	No. of units	Product number	Unit price	Total price
Pump	SQE				
Remote control	R100				
Control unit	CU 300				
SQE Speed Calculation program					

## SQE with manual speed control

### Functioning and benefits

Manual speed control of the SQE pumps is possible by means of R100 and an SPP 1 potentiometer.

This application is especially suitable for sampling from groundwater monitoring wells. The monitoring well is purged at high speed and the sample is taken at a low speed (quiet flow). For contaminated groundwater the SQE-NE type range is recommended.

In case frequent sampling is required, dedicated installation of the pump is recommended, thus eliminating wear caused by frequent assembly and dismantling the installation.

Furthermore, dedicated installations saves the costs of assembling and dismantling the installation.

**Important:** Through dedicated installation the transfer of contamination from one monitoring well to another is avoided.

### Dry-running protection

The value  $P_{cut\ out}$ , ensuring dry-running protection, is factory-set for the SQE pump. If the speed of the pump is reduced more than 1,000 rpm, the value of  $P_{cut\ out}$  must be readjusted by means of CU 300 and R100.

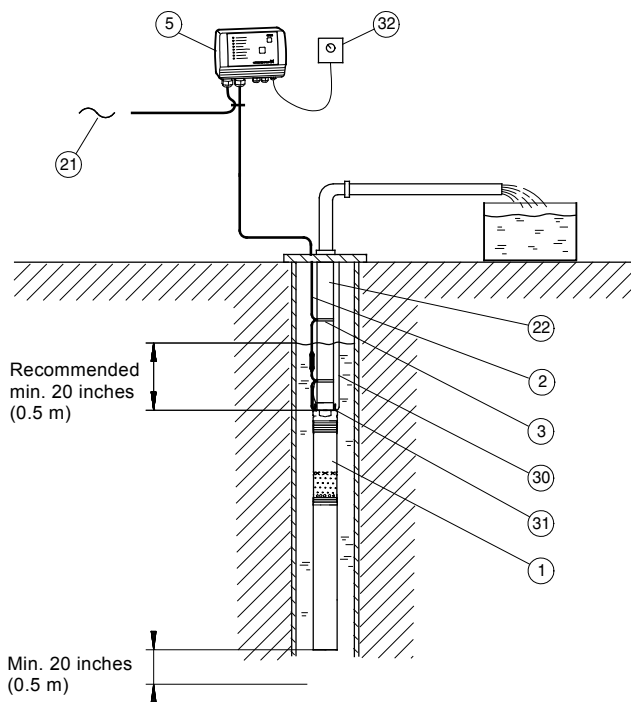

- 1 SQE pump
- 2 Cable
- 3 Cable clips
- 5 Control unit, CU 300
- 21 Mains connection
- 22 Riser pipe
- 30 Stainless-steel straining wire
- 31 Stainless-steel wire clamps, 2 per lifting eye
- 32 Potentiometer, SPP 1

Fig. 12 Application example: Sampling/manual speed control of SQE

TM01 9028 4801

## Sampling/manual speed control of SQE

Pos.	Part	Type	No. of units	Product number	Unit price	Total price
1	Pump	SQE				
2	Cable					
3	Cable clips					
5	Control unit	CU 300				
22	Riser pipe					
30	Stainless-steel straining wire					
31	Wire clamps		2 per lifting eye			
32	Potentiometer	SPP 1				

## Performance range

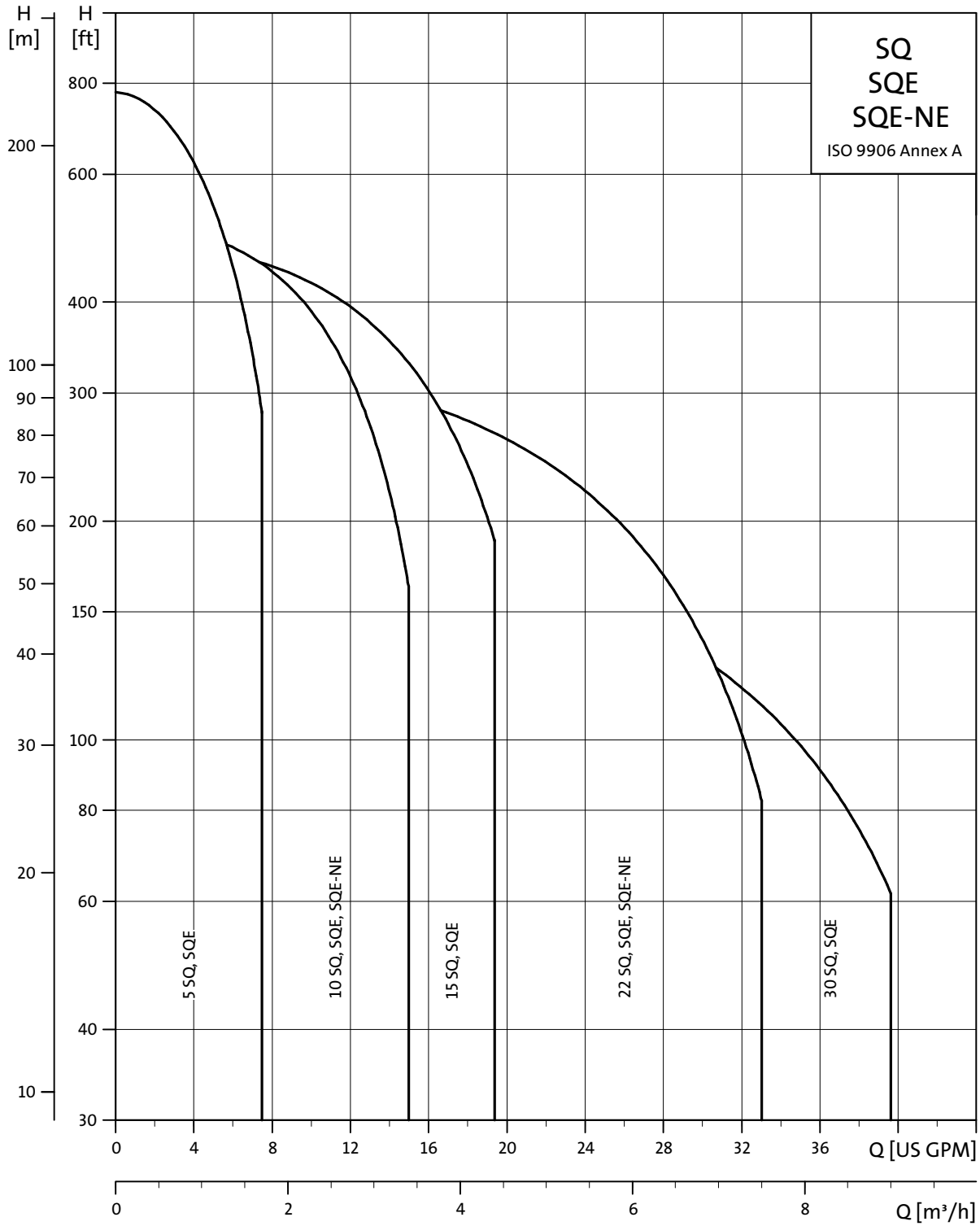

## Installation

The SQ and SQE, SQE-NE may be installed vertically, horizontally or in any position in between.

**Note:** The pump must not fall below the horizontal level in relation to the motor.

The following features ensure simple installation of the pump:

- Built-in check valve with spring
- low weight ensuring user-friendly handling
- installation in 3" or larger boreholes
- only on/off switch is needed, which means that no extra motor starter / starter box is necessary.

For horizontal installation a flow sleeve is recommended in order to:

- ensure sufficient flow velocity past the motor and thus provide sufficient cooling
- prevent motor and electronic unit from being buried in sand or mud.

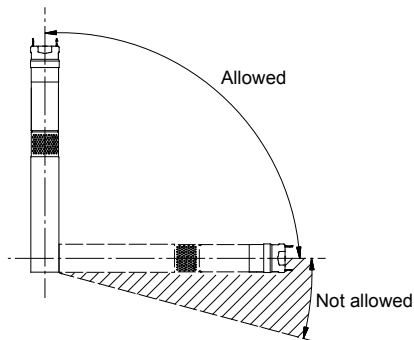

TM01 1375 1498

Fig. 13 SQE installation

## System sizing guide

### Step 1

Calculate minimum head requirements at no flow conditions:

$$H_{\max} \text{ (required)} = \text{dynamic head} + \text{system pressure (in feet)} + \text{above grade elevation} + \text{friction loss}$$

### Step 2

Select pump from chart as follows:

- Choose model family based on the desired flow rate (i.e. 15SQE for a flow rate of 15 gpm)
- Select the first model with a value in Column 2 greater than the  $H_{\max}$  calculated in Step 1 (For example: the choice for a 22 gpm model with an  $H_{\max}$  of 140 ft would be the 22SQE-160).
- Double check your selection in the performance curves; see *Curve charts* on p. 19.

System sizing matrix		
Pump type Model B	Column 1	Column 2
	Shutoff head (0 gpm) @ 3000 rpm min. speed	Head @ rated gpm @ 10700 rpm max. speed
	TDH [feet]	TDH [feet]
5SQE-90	11	86
5SQE-140	17	131
5SQE-180	22	177
5SQE-230	28	222
5SQE-270	34	270
5SQE-320	39	315
5SQE-360	45	360
5SQE-410	51	405
5SQE-450	56	450
10SQE-110	12	105
10SQE-160	17	164
10SQE-200	23	215
10SQE-240	29	267
10SQE-290	34	328
10SQE-330	40	390
15SQE-70	10	75
15SQE-110	14	123
15SQE-150	19	164
15SQE-180	24	205
15SQE-220	29	246
15SQE-250	33	287
15SQE-290	38	328
22SQE-40	5	36
22SQE-80	9	77
22SQE-120	14	117
22SQE-160	18	159
22SQE-190	23	200
22SQE-220	27	240
30SQE-40	5	33
30SQE-90	11	82
30SQE-130	16	126

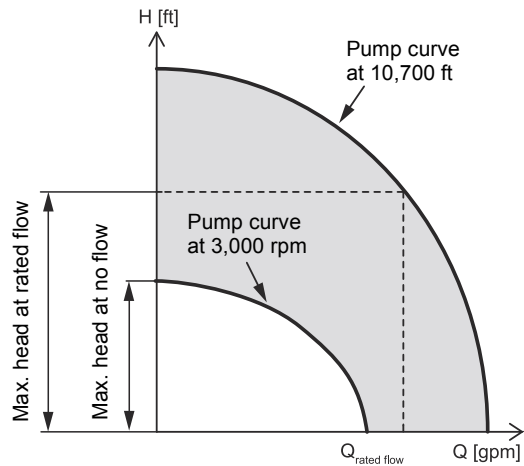

TM01 8547 0400

**Fig. 14** Recommended sizing

Note: All calculated head requirements must lie between the selected pump models minimum and maximum speed curves.

## SQ, SQE, SQE-NE cable sizing chart

Motor rating			Copper wire size (AWG)						
Volts	Hp	Amps	14	12	10	8	6	4	2
115	0.5	12	140	220	360	550	880	1390	2260
230	0.5	5.2	640	1000	1660	2250	4060	—	—
230	0.75	8.4	400	620	1030	1580	2510	3970	—
230	1	11.2	300	460	770	1190	1890	2980	4850
230	1.5	12	280	430	720	1110	1760	2780	4530

Cable length in feet.

Note: shaded values do not apply when using a CU 301 as its max. recommended cable length is 650 ft.

## 5 SQ, SQE

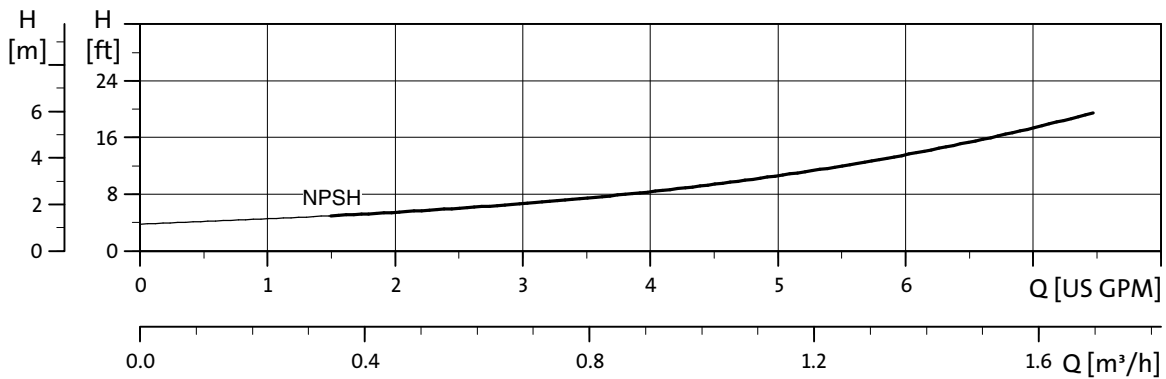
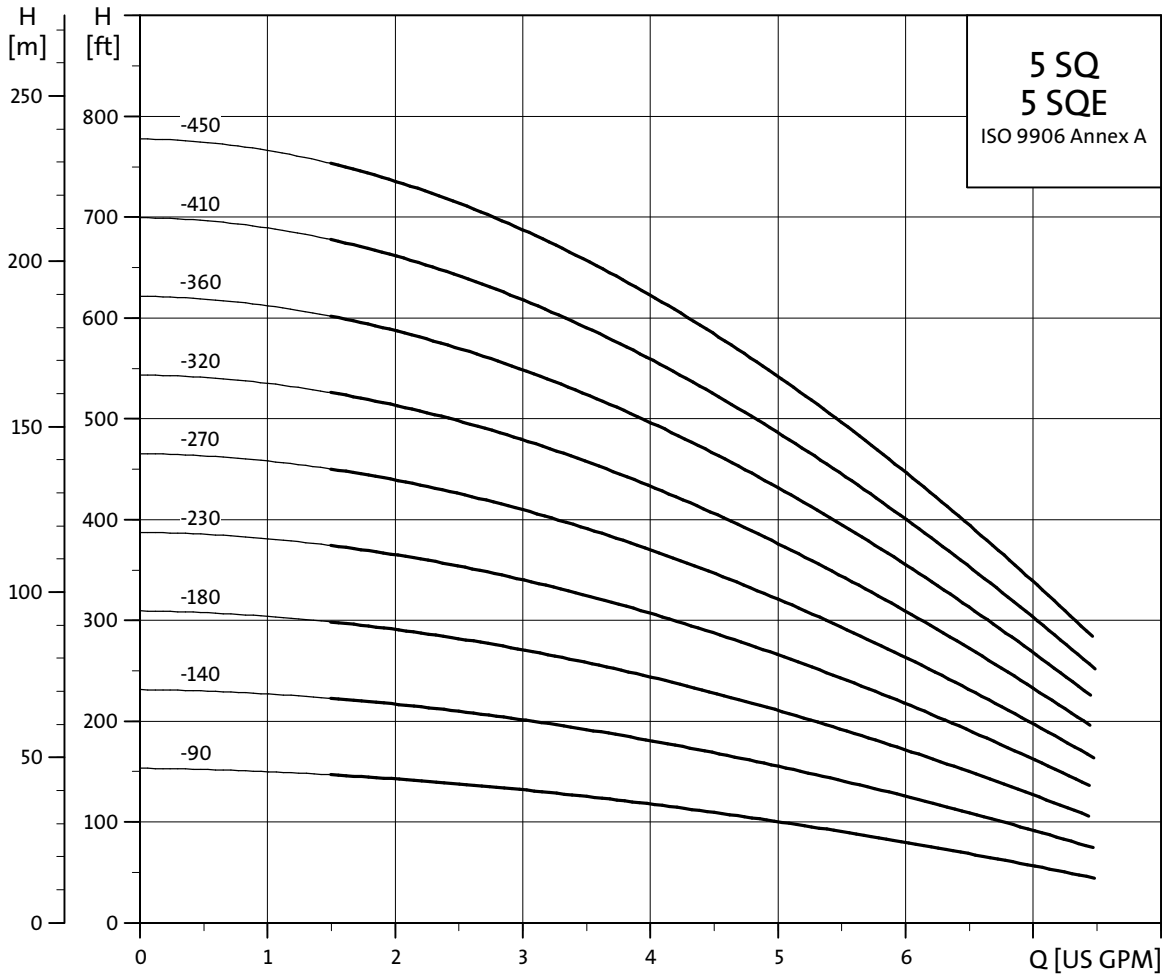

TM04 7463 2010

## 10 SQ, SQE

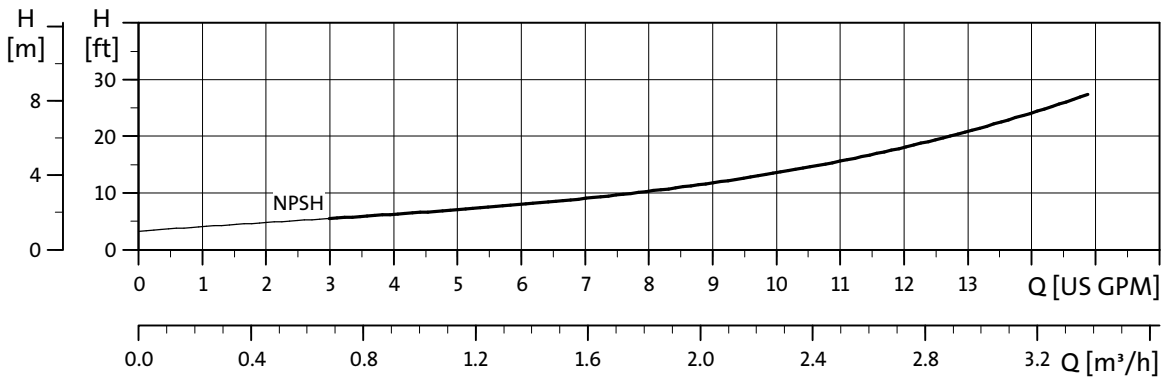
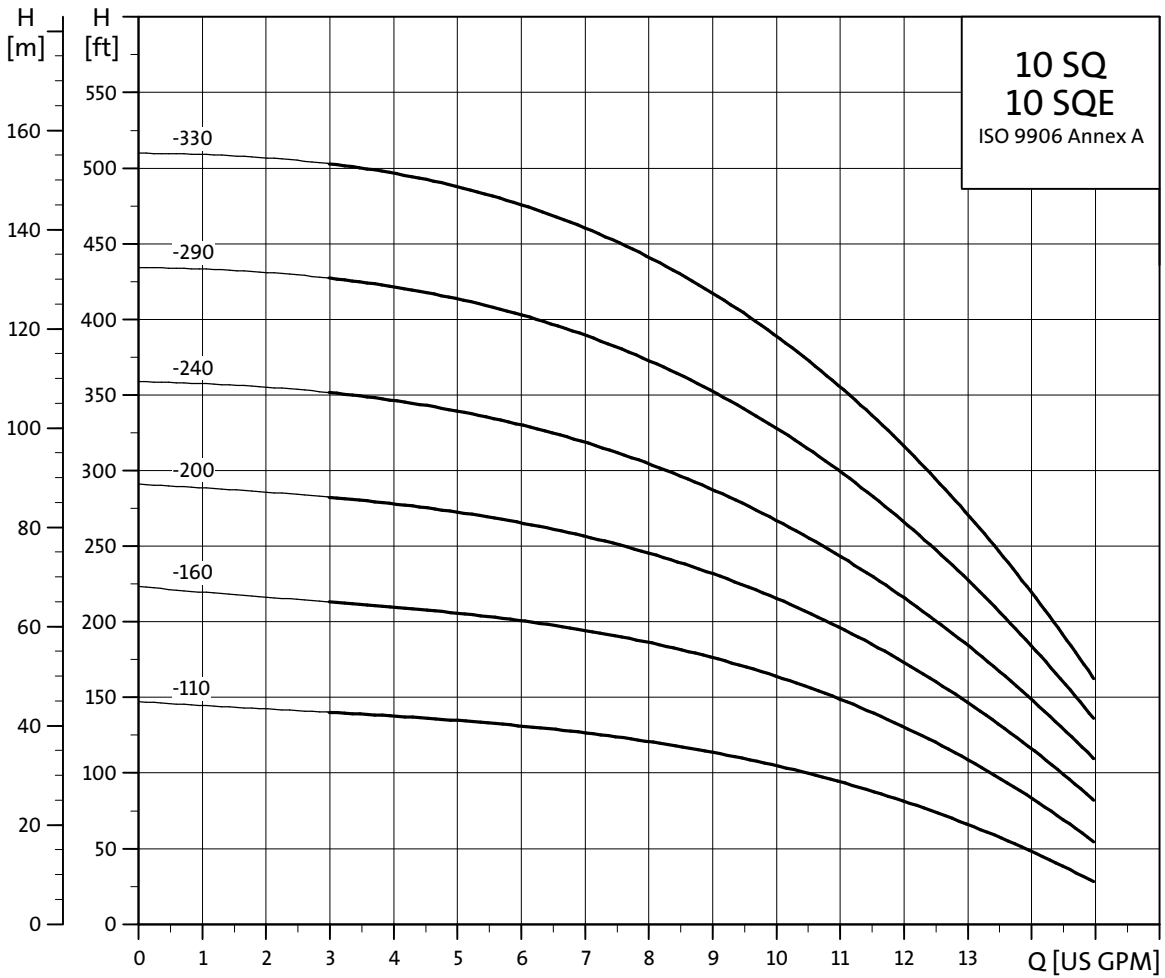

TM04 7464 2010

## 15 SQ, SQE

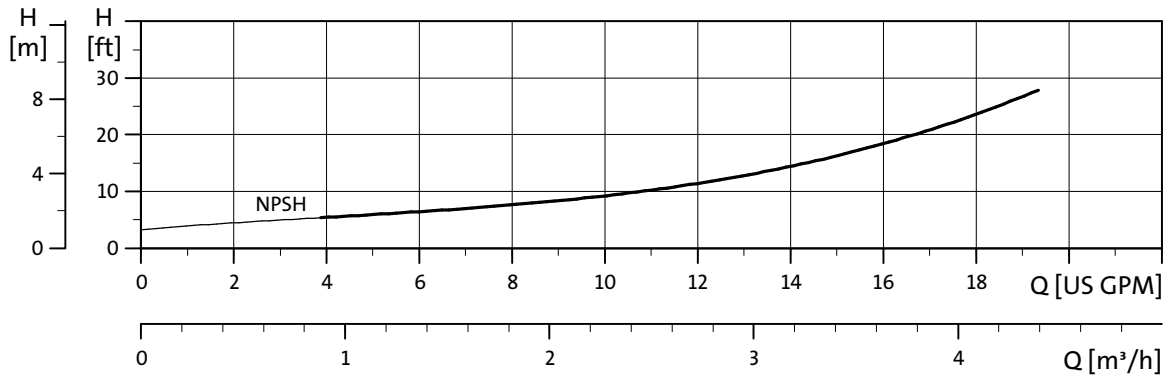
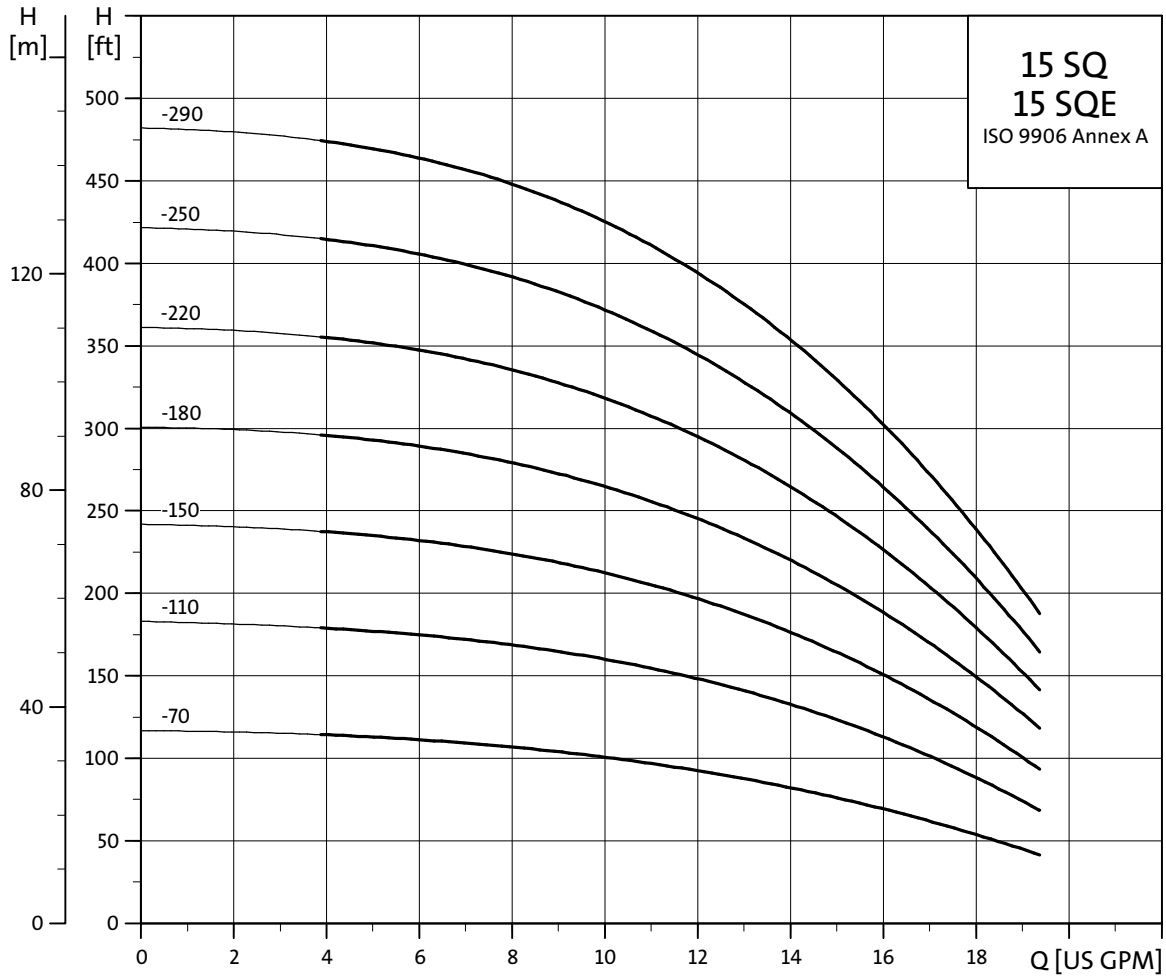

TM04 7465 2010

## 22 SQ, SQE

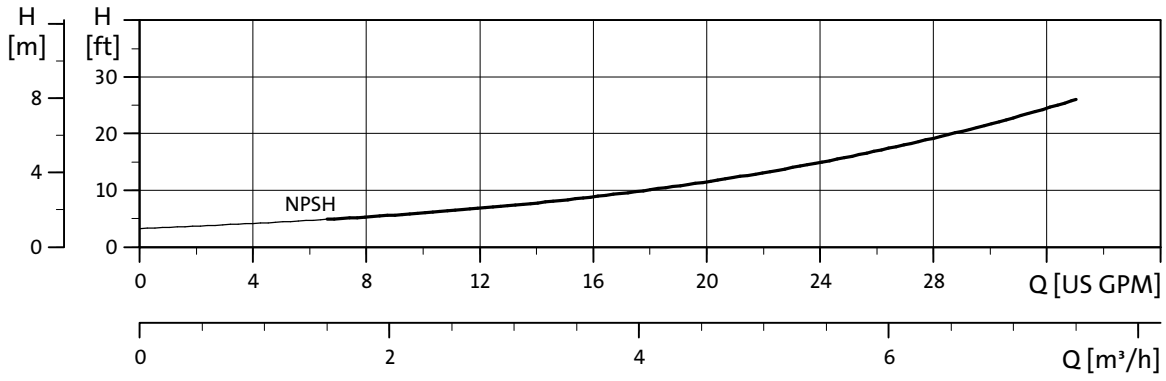
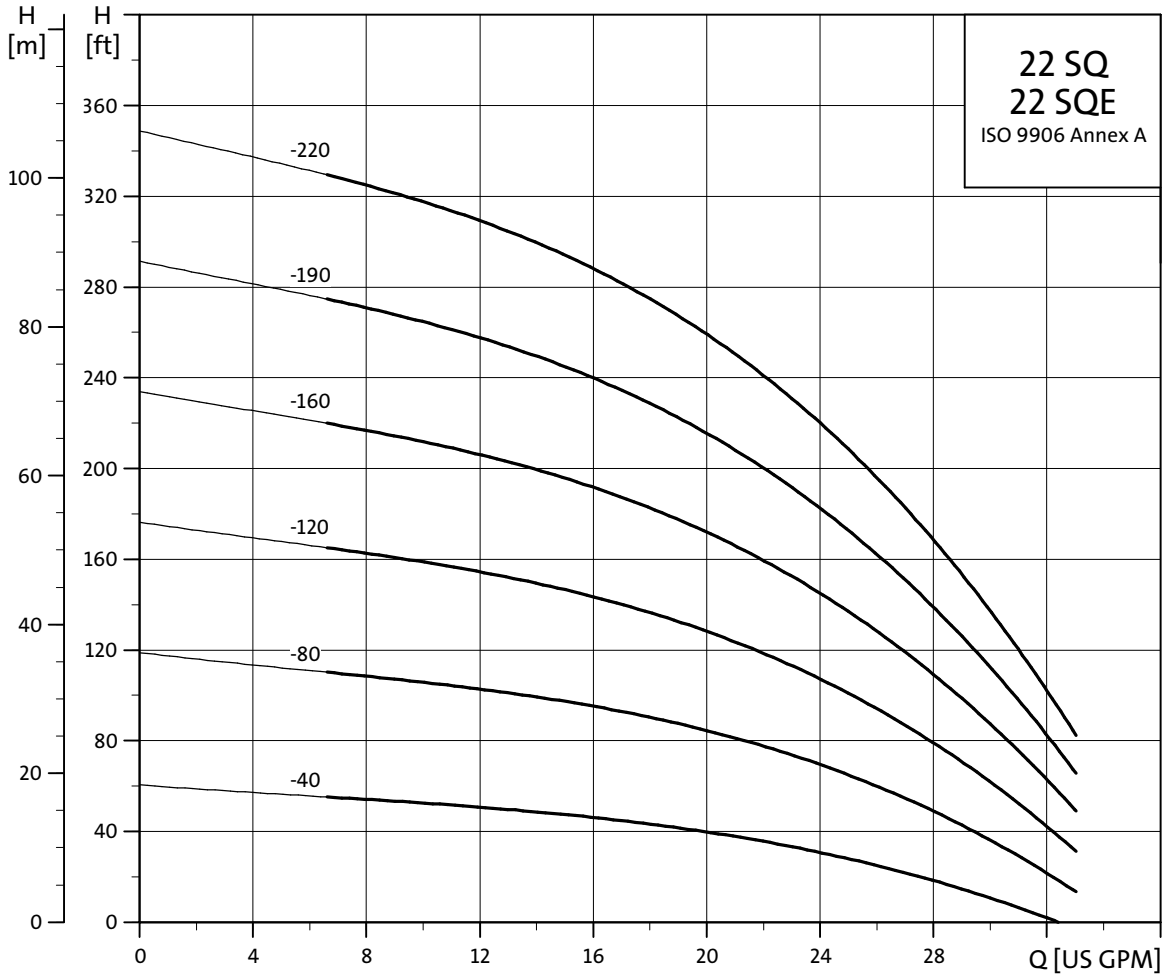

TM04 7466 2010

## 30 SQ, SQE

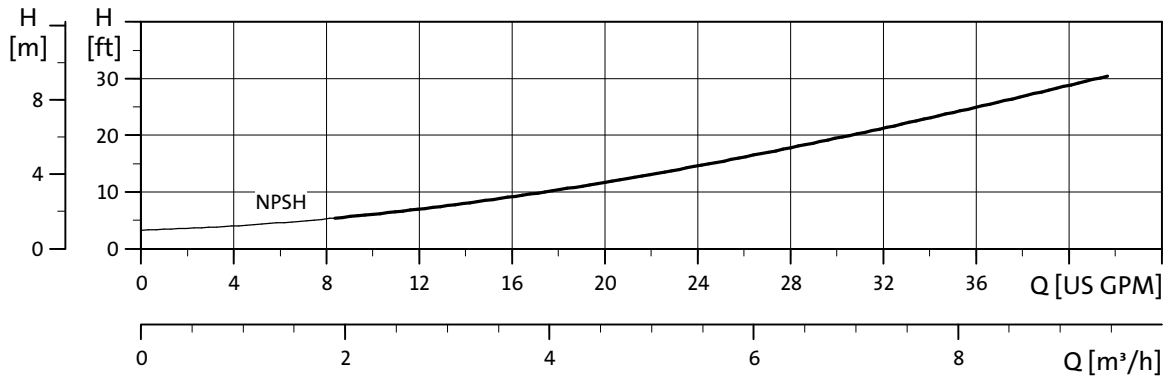
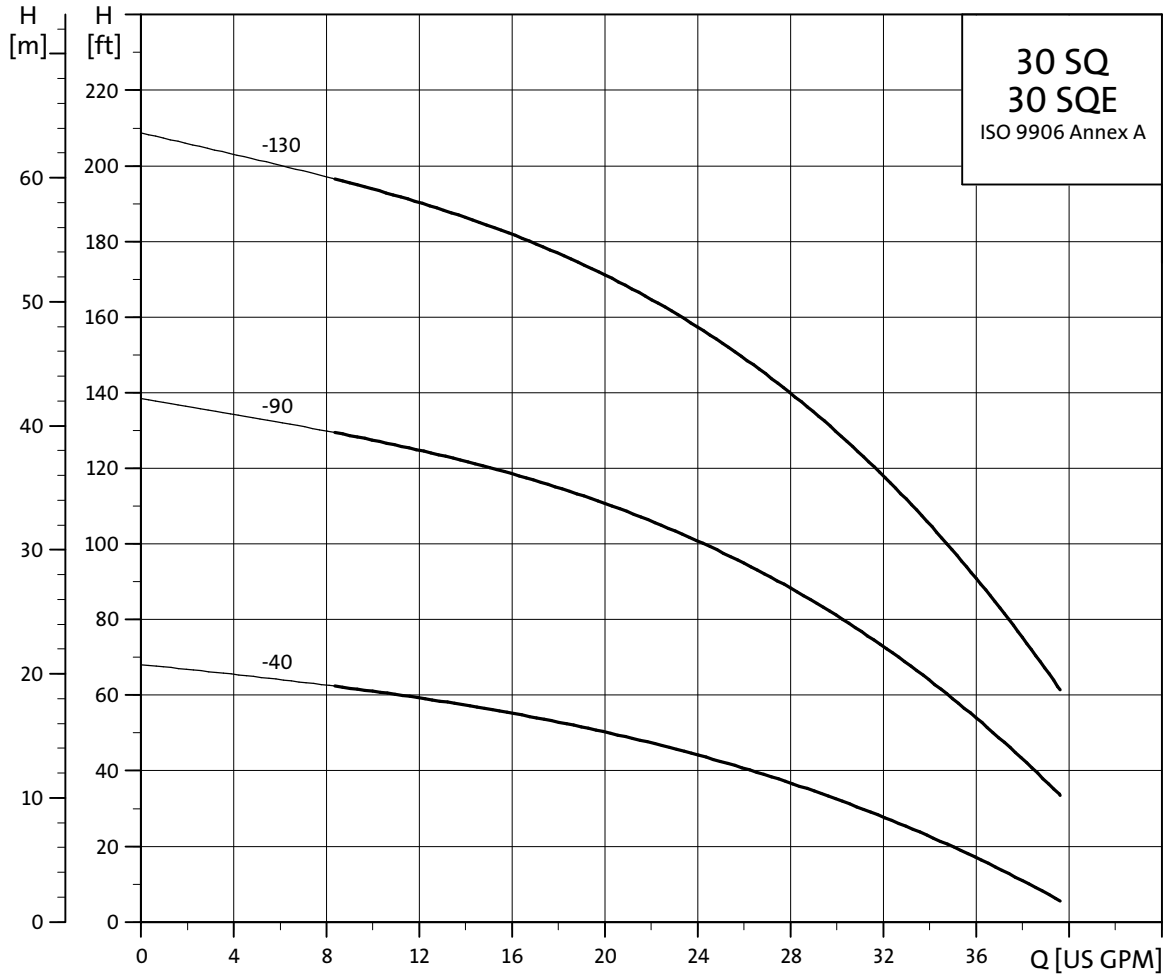

TM04 7467 2010

## 10 SQE-NE

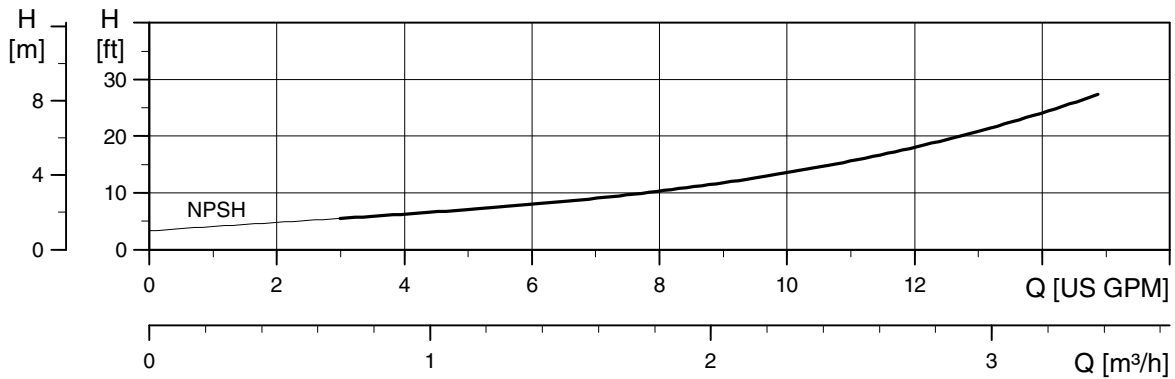
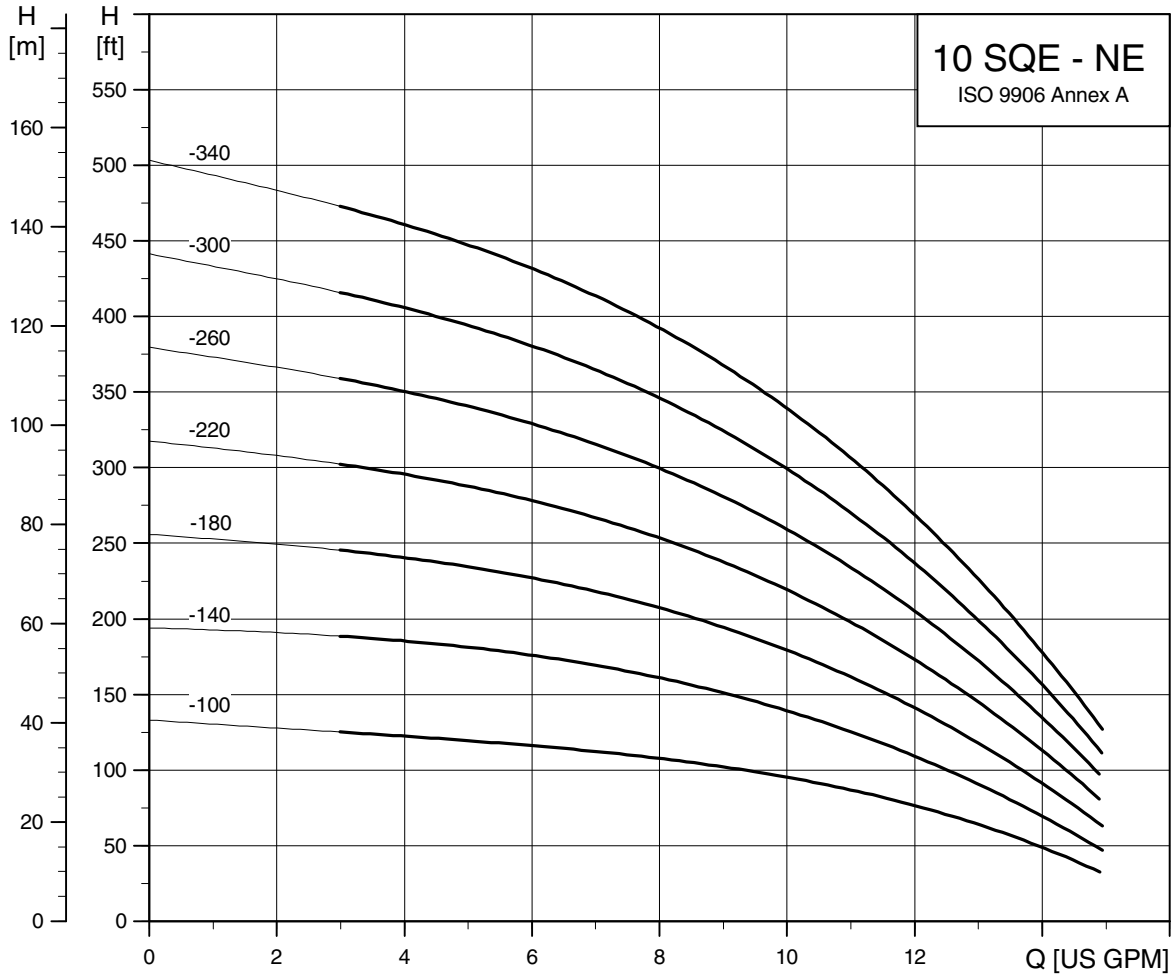

TM04 7468 2010

## 22 SQE, SQE-NE

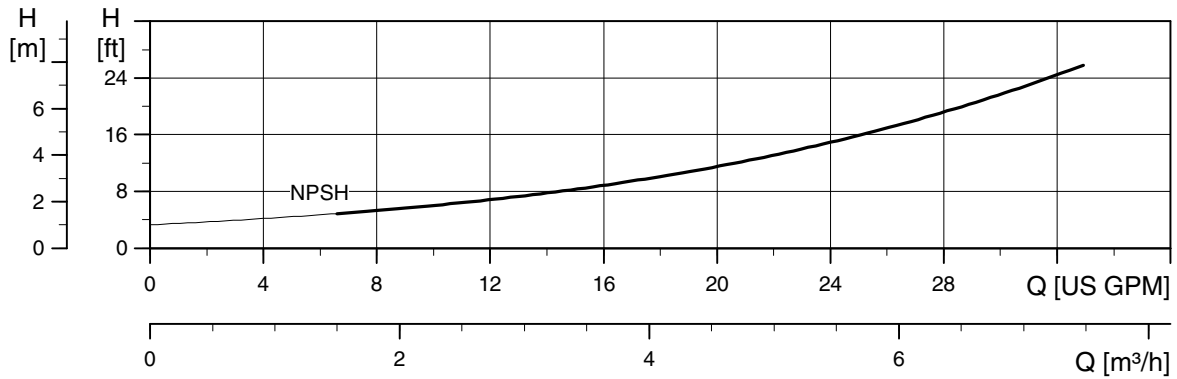
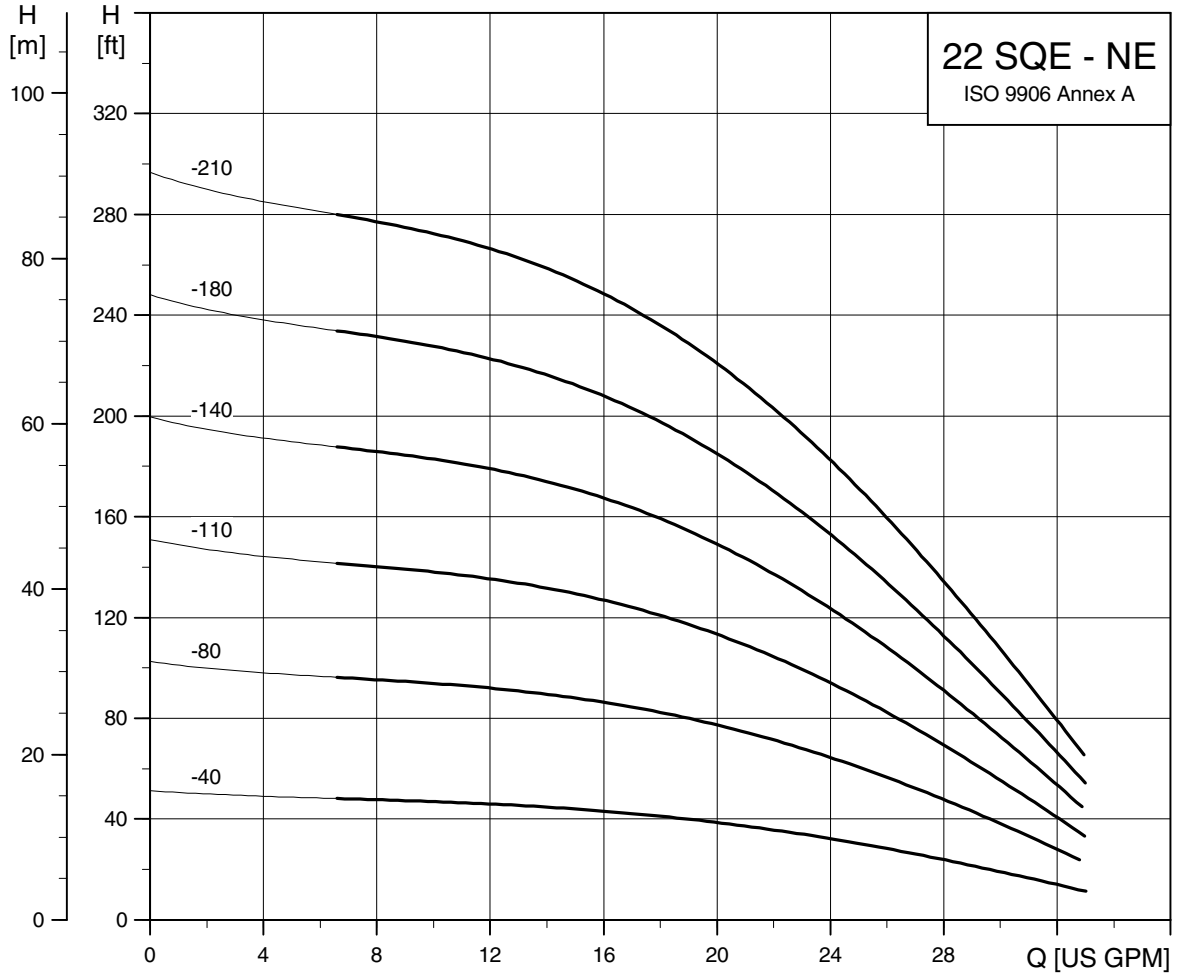

TM04 7469 2010

## Electrical data

Supply voltage:	1x200-240V +6%/-10%, 50/60 Hz, PE 1x100-115V +6%/-10%, 50/60 Hz, PE
Operation via generator:	As a minimum, the generator output must be equal to the motor P1[kw] + 10%
Starting current:	The motor starting current is equal to the highest value stated on the motor nameplate
Starting:	Soft Start
Run-up time:	Maximum: 2 seconds
Motor protection:	Motor is protected against: <ul style="list-style-type: none"> <li>- Dry running</li> <li>- overvoltage</li> <li>- undervoltage</li> <li>- overload</li> <li>- overtemperature.</li> </ul>
Power factor:	PF=1
Motor cable:	3 wire, 14AWG XLPE, 5 ft
Motor liquid:	Type SML 2
pH Values:	SQ and SQE: 5 to 9 SQE-NE: 2 to 13
Liquid temperature:	The temperature of the pumped liquid must not exceed 86 °F (30 °C)

Note: If liquids with a viscosity higher than that of water are to be pumped, please contact Grundfos.

## Control units CU 300 and CU 301

Voltage:	1 x 100-240 V – 10 %/+ 6 %, 50/60 Hz, PE
Power consumption:	5 W
Current consumption:	Maximum 130 mA
Enclosure class:	IP 55
Ambient temperature:	During operation: -22 °F to +122 °C (-30 °C to +50 °C) During storage: -22 °F to 140 °F (-30 °C to +60 °C)
Relative air humidity:	95 %.
Pump cable:	Maximum length between CU 300 or CU 301 and pump: 650 ft (198 m)
Back-up fuse:	Maximum: 16 A
Radio noise:	CU 300 and CU 301 comply with EMC Directive 89/336/EEC. Approved according to the standards EN 55014 and EN 55014-2
Marking:	CE, cUL (CU 301)
Load:	Max. 100 mA

## Operating conditions

Minimum ambient fluid temperature:	+34 °F (+1 °C)
Maximum ambient fluid temperature:	+86 °F (+30 °C)
Well diameter:	3-inch or larger
Installation depth (maximum):	500 feet below static water level

## Storage conditions

Minimum ambient temperature:	-4 °F (-20 °C)
Maximum ambient temperature:	+140 °F (+60 °F)
Frost protection:	If the pump has to be stored after use, it must be stored at a frost-free location, or it must be ensured that the motor liquid is frost-proof.

## SQ, SQE motor data

Pump type	Hp	Voltage	Full load amps		Overload amps		Min. well diameter	Discharge
			230V	115V	230V	115V		
5SQE05-90	1/2	230V / 115V	2.1	4.2	5	11	3"	1" NPT
5SQE05-140	1/2	230V / 115V	2.9	6.0	5	11	3"	1" NPT
5SQE05-180	1/2	230V / 115V	3.7	7.7	5	11	3"	1" NPT
5SQE07-230	3/4	230V	4.6	-	8	-	3"	1" NPT
5SQE07-270	3/4	230V	5.3	-	8	-	3"	1" NPT
5SQE07-320	3/4	230V	6.2	-	8	-	3"	1" NPT
5SQE10-360	1	230V	7.2	-	11	-	3"	1" NPT
5SQE10-410	1	230V	8.1	-	11	-	3"	1" NPT
5SQE15-450	1 1/2	230V	9.2	-	12	-	3"	1" NPT
<hr/>								
10SQE05-110	1/2	230V / 115V	2.9	6.1	5	11	3"	1 1/4" NPT
10SQE05-160	1/2	230V / 115V	4.1	8.6	8	11	3"	1 1/4" NPT
10SQE07-200	3/4	230V	5.3	-	8	-	3"	1 1/4" NPT
10SQE7-240	3/4	230V	6.0	-	8	-	3"	1 1/4" NPT
10SQE10-290	1	230V	7.7	-	11	-	3"	1 1/4" NPT
10SQE15-330	1 1/2	230V	8.9	-	12	-	3"	1 1/4" NPT
<hr/>								
15SQE05-70	1/2	230V / 115V	2.9	6.0	5	11	3"	1 1/4" NPT
15SQE05-110	1/2	230V / 115V	4.0	8.3	5	11	3"	1 1/4" NPT
15SQE07-150	3/4	230V	5.1	-	8	-	3"	1 1/4" NPT
15SQE07-180	3/4	230V	6.2	-	8	-	3"	1 1/4" NPT
15SQE10-220	1	230V	7.4	-	11	-	3"	1 1/4" NPT
15SQE10-250	1	230V	8.4	-	11	-	3"	1 1/4" NPT
15SQE15-290	1 1/2	230V	9.7	-	12	-	3"	1 1/4" NPT
<hr/>								
22SQE05-40	1/2	230V / 115V	1.9	3.9	5	-	3"	1 1/2" NPT
22SQE05-80	1/2	230V / 115V	3.4	7.2	5	-	3"	1 1/2" NPT
22SQE07-120	3/4	230V	4.9	-	8	-	3"	1 1/2" NPT
22SQE07-160	3/4	230V	6.4	-	8	-	3"	1 1/2" NPT
22SQE10-190	1	230V	7.9	-	11	-	3"	1 1/2" NPT
22SQE15-220	1 1/2	230V	9.5	-	12	-	3"	1 1/2" NPT
<hr/>								
30SQE05-40	1/2	230V / 115V	2.8	5.7	5	-	3"	1 1/2" NPT
30SQE07-90	3/4	230V	5.2	-	8	-	3"	1 1/2" NPT
30SQE10-130	1	230V	7.6	-	11	-	3"	1 1/2" NPT

## SQ, SQE and SQE-NE dimensions and weights

### SQ, SQE

Model	Hp	Motor size	Discharge size	Dimensions in inches					Approx. ship. wt.
				A	B	C	D	E	
5SQ/SQE05-90	1/2	3"	1" NPT	30.4	19.8	10.6	2.6	2.9	12
5SQ/SQE05-140	1/2	3"	1" NPT	30.4	19.8	10.6	2.6	2.9	12
5SQ/SQE05-180	1/2	3"	1" NPT	31.5	19.8	11.6	2.6	2.9	12
5SQ/SQE07-230	3/4	3"	1" NPT	33.6	19.8	13.7	2.6	2.9	13
5SQ/SQE07-270	3/4	3"	1" NPT	33.6	19.8	13.7	2.6	2.9	13
5SQ/SQE07-320	3/4	3"	1" NPT	34.6	19.8	14.8	2.6	2.9	13
5SQ/SQE10-360	1	3"	1" NPT	38.2	21.3	16.9	2.6	2.9	16
5SQ/SQE10-410	1	3"	1" NPT	38.2	21.3	16.9	2.6	2.9	16
5SQ/SQE15-450	1 1/2	3"	1" NPT	39.3	21.3	18.0	2.6	2.9	16
10SQ/SQE05/110	1/2	3"	1 1/4" NPT	30.4	19.8	10.6	2.6	2.9	12
10SQ/SQE05/160	1/2	3"	1 1/4" NPT	30.4	19.8	10.6	2.6	2.9	12
10SQ/SQE07/200	3/4	3"	1 1/4" NPT	31.5	19.8	11.6	2.6	2.9	13
10SQ/SQE07/260	3/4	3"	1 1/4" NPT	33.6	19.8	13.7	2.6	2.9	13
10SQ/SQE10/290	1	3"	1 1/4" NPT	35.0	21.3	13.7	2.6	2.9	16
10SQ/SQE15/330	1 1/2	3"	1 1/4" NPT	36.14	21.3	14.8	2.6	2.9	16
15SQ/SQE05/70	1/2	3"	1 1/4" NPT	30.4	19.8	10.6	2.6	2.9	12
15SQ/SQE05/110	1/2	3"	1 1/4" NPT	30.4	19.8	10.6	2.6	2.9	12
15SQ/SQE07/150	3/4	3"	1 1/4" NPT	31.5	19.8	11.6	2.6	2.9	13
15SQ/SQE07/180	3/4	3"	1 1/4" NPT	33.6	19.8	13.7	2.6	2.9	13
15SQ/SQE10/220	1	3"	1 1/4" NPT	35.0	21.3	13.7	2.6	2.9	16
15SQ/SQE10/250	1	3"	1 1/4" NPT	36.1	21.3	14.8	2.6	2.9	16
15SQ/SQE10/290	1 1/2	3"	1 1/4" NPT	38.2	21.3	16.9	2.6	2.9	16
22SQ/SQE05/40	1/2	3"	1 1/2" NPT	30.4	19.8	10.6	2.6	2.9	12
22SQ/SQE05/80	1/2	3"	1 1/2" NPT	30.4	19.8	10.6	2.6	2.9	12
22SQ/SQE07/120	3/4	3"	1 1/2" NPT	31.5	19.8	11.6	2.6	2.9	13
22SQ/SQE07/160	3/4	3"	1 1/2" NPT	33.6	19.8	13.7	2.6	2.9	13
22SQ/SQE10/190	1	3"	1 1/2" NPT	38.2	21.3	16.9	2.6	2.9	16
22SQ/SQE15/220	1 1/2	3"	1 1/2" NPT	38.2	21.3	16.9	2.6	2.9	16
30SQ/SQE05/40	1/2	3"	1 1/2" NPT	30.4	19.8	10.6	2.6	2.9	12
30SQ/SQE07/90	3/4	3"	1 1/2" NPT	30.4	19.8	10.6	2.6	2.9	13
30SQ/SQE10/130	1	3"	1 1/2" NPT	35.0	21.3	13.7	2.6	2.9	13

### SQE-NE

10SQE-05-100NE	1/2	3"	1 1/4" NPT	30.4	19.8	10.6	2.6	2.9	12
10SQE-05-140NE	1/2	3"	1 1/4" NPT	30.4	19.8	10.6	2.6	2.9	12
10SQE-05-180NE	3/4	3"	1 1/4" NPT	31.5	19.8	11.6	2.6	2.9	13
10SQE-07-220NE	3/4	3"	1 1/4" NPT	33.6	19.8	13.7	2.6	2.9	13
10SQE-10-260NE	1	3"	1 1/4" NPT	35.0	21.3	13.7	2.6	2.9	16
10SQE-10-300NE	1	3"	1 1/4" NPT	36.1	21.3	14.8	2.6	2.9	16
10SQE-10-340NE	1	3"	1 1/4" NPT	38.2	21.3	16.9	2.6	2.9	16
22SQE05-40NE	1/2	3"	1 1/2" NPT	30.4	19.8	10.6	2.6	2.9	12
22SQE05-80NE	1/2	3"	1 1/2" NPT	30.4	19.8	10.6	2.6	2.9	12
22SQE07-110NE	3/4	3"	1 1/2" NPT	31.5	19.8	11.6	2.6	2.9	13
22SQE07-140NE	3/4	3"	1 1/2" NPT	33.6	19.8	13.7	2.6	2.9	13
22SQE10-180NE	1	3"	1 1/2" NPT	38.2	21.3	16.9	2.6	2.9	16
22SQE10-210NE	1	3"	1 1/2" NPT	38.2	21.3	16.9	2.6	2.9	16

## Materials of construction

SQ, SQE	
Component	Splined shaft
Valve casing	Polyamide
Discharge chamber	304 stainless steel
Valve guide	Polyamide
Valve spring	316LN stainless steel
Valve cone	Polyamide
Valve seat	NBR rubber
O-ring	NBR rubber
Lock ring	310 stainless steel
Top bearing	NBR rubber
Top chamber	Polyamide
Guide vanes	Polyamide
Impeller	Polyamide w/ tungsten carbide bearings
Bottom chamber	Polyamide
Neck ring	TPU / PBT
Bearing	Aluminum oxide
Suction interconnector	Polyamide
Ring	304 stainless steel
Pump sleeve	304 stainless steel
Pressure equalization cone	Polyamide
Spacer	Polyamide
Sand trap	316 stainless steel
Shaft w/coupling	304 stainless steel
Cable guard	304 stainless steel

SQE-NE	
Component	Splined shaft
Valve casing	PVDF
Discharge chamber	316 stainless steel
O-ring	FPM rubber
Valve cone	PVDF
Valve seat	FPM rubber
Top chamber	PVDF
Empty chamber	PVDF
Top bearing	FPM rubber
Neck ring	PVDF
Lock ring	316 stainless steel
Guide vanes	PVDF
Bottom chamber	PVDF
Impeller w/ tungsten carbide bearing	PVDF
Suction interconnector	PVDF
Ring	316 stainless steel
Shaft w/coupling	Sintered steel
Cable guard	316 stainless steel
Cable guard screws	316 stainless steel
Pressure equalization cone	PVDF
Valve spring	316 stainless steel
Pump sleeve	316 stainless steel
Valve guide	PVDF
Spacer	316 stainless steel

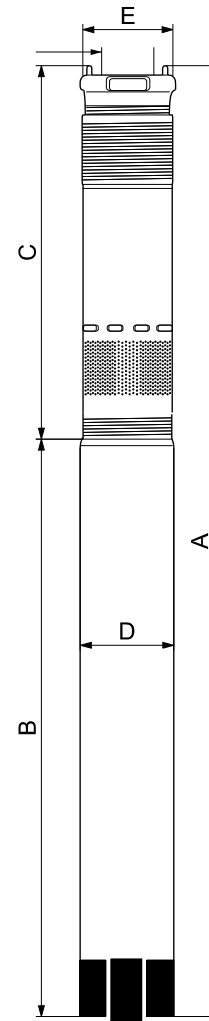

Discharge sizes:  
 1" NPT 5SQ/SQE  
 1 1/4" NPT 10 - 15 SQ/SQE  
 1 1/2" NPT 22-30 SQ/SQE

TM04 7522 2110

## Material specification

Pump						
Pos.	Component	Material	DIN W-Nr. SQ/SQE	AISI	DIN W-Nr. SQE-NE	AISI
1	Valve casing	Polyamide	1.4301	304	1.4401	316
1a	Discharge chamber	Stainless steel				
1d	O-ring	NBR rubber				
2	Valve cup	Polyamide				
3	Valve seat	NBR rubber				
4a	Empty chamber	Polyamide				
6	Top bearing	NBR rubber				
7	Neck ring	TPU / PBT				
7a	Lock ring	Stainless spring steel	1.4301	310	1.4401	316
7b	Neck ring retainer	Polyamide				
9b	Chamber top	Polyamide				
9c	Chamber bottom	Polyamide				
13	Impeller with tungsten carbide bearing	Polyamide				
14	Suction inter-connector	Polyamide				
14a	Ring	Stainless steel	1.4301	304	1.4401	316
16	Shaft with coupling	Stainless steel	1.4301	304	1.4401	316
18	Cable guard	Sintered steel	1.4301	304	1.4401	316
18a	Screws for cable guard	Stainless steel	1.4301	316	1.4401	316
18b						
30	Cone for pressure equalization	Polyamide				
32	Guide vanes	Polyamide				
39	Spring	Stainless spring steel	1.4406	316LN	1.4406	316LN
55	Pump sleeve	Stainless steel	1.4301	304	1.4401	316
64	Priming screw	Polyamide				
70	Valve guide	Polyamide				
86	Lip seal ring	NBR rubber				
87	Cone for pressure equalization complete	Polyamide / NBR rubber				

Motor						
Pos.	Component	Material	DIN W-Nr. SQ-SQE	AISI	DIN W-Nr. SQE-NE	AISI
201	Stator	Stainless steel	1.4301	304	1.4401	316
202	Rotor	Stainless steel	1.4301	304	1.4401	316
202a	Stop ring	PP				
202b	Filter	Polyester				
203	Thrust bearing	Carbon				
205	Radial bearing	Ceramic tungsten carbide				
220	Motor cable with plug	EPR				
222a	Filling plug	MS 3: NBR MSE 3: FKM				
224	O-ring	FKM				
225	Top cover	PPS				
232	Shaft seal	MS 3: NBR MSE 3: FKM				
	Motor liquid	SML-2				

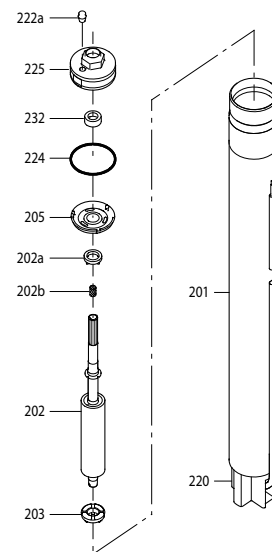
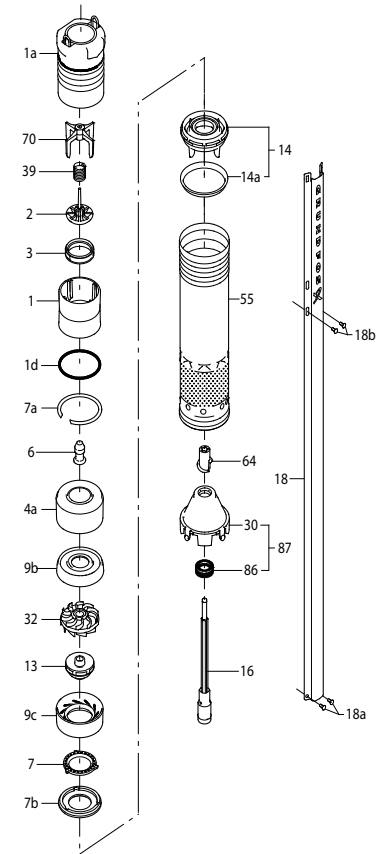

TM01 2745 2010

## CU 301

The CU 301 is a control and communication unit developed especially for the SQE submersible pumps in constant-pressure applications.

The CU 301 control unit provides:

- Full control of the SQE pumps
- two-way communication with the SQE pumps
- possibility of adjusting the pressure
- alarm indication (LED) when service is needed
- possibility of starting, stopping and resetting the pump simply by means of a push-button
- configuration with R100 remote control.

The CU 301 communicates with the pump via mains borne signalling (Power Line Communication), meaning that no extra cables are required between the CU 301 and the pump.

The CU 301 features the following indications (see drawing in right column):

1. Pump running indicator
2. System pressure setting
3. System ON/OFF
4. Button lock indicator
5. Dry-running indicator
6. Service needed in case of:
  - no contact to pump
  - overvoltage
  - undervoltage
  - speed reduction
  - overtemperature
  - overload
  - sensor defective.

The CU 301 incorporates:

- External signal input for pressure sensor
- connection to an operating relay for indication of pump operation.

### Optional R100 remote control

Wireless infrared remote control of the CU 301 is possible by means of the R100.

Using the R100, it is possible to monitor and change the operating parameters, see the R100 menu structure on page 32.

The R100 is a valuable tool in case fault finding is required.

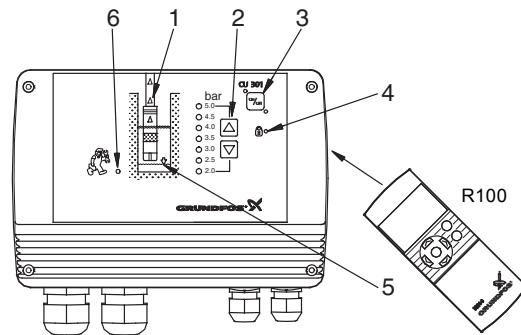

Fig. 15 CU 301 control unit

TM03 3426 0406

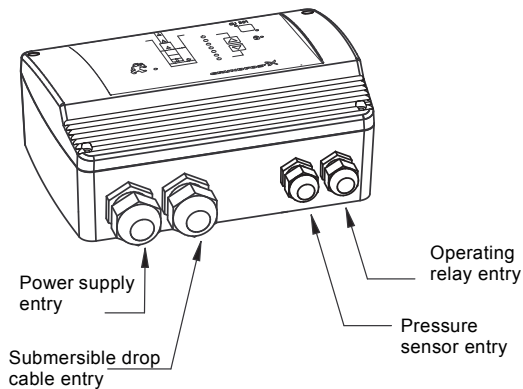

Fig. 16 CU 301 entry ports

TM02 3427 0406

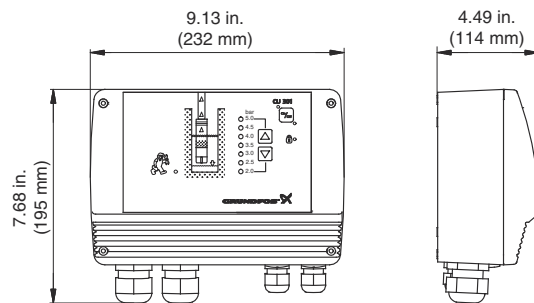
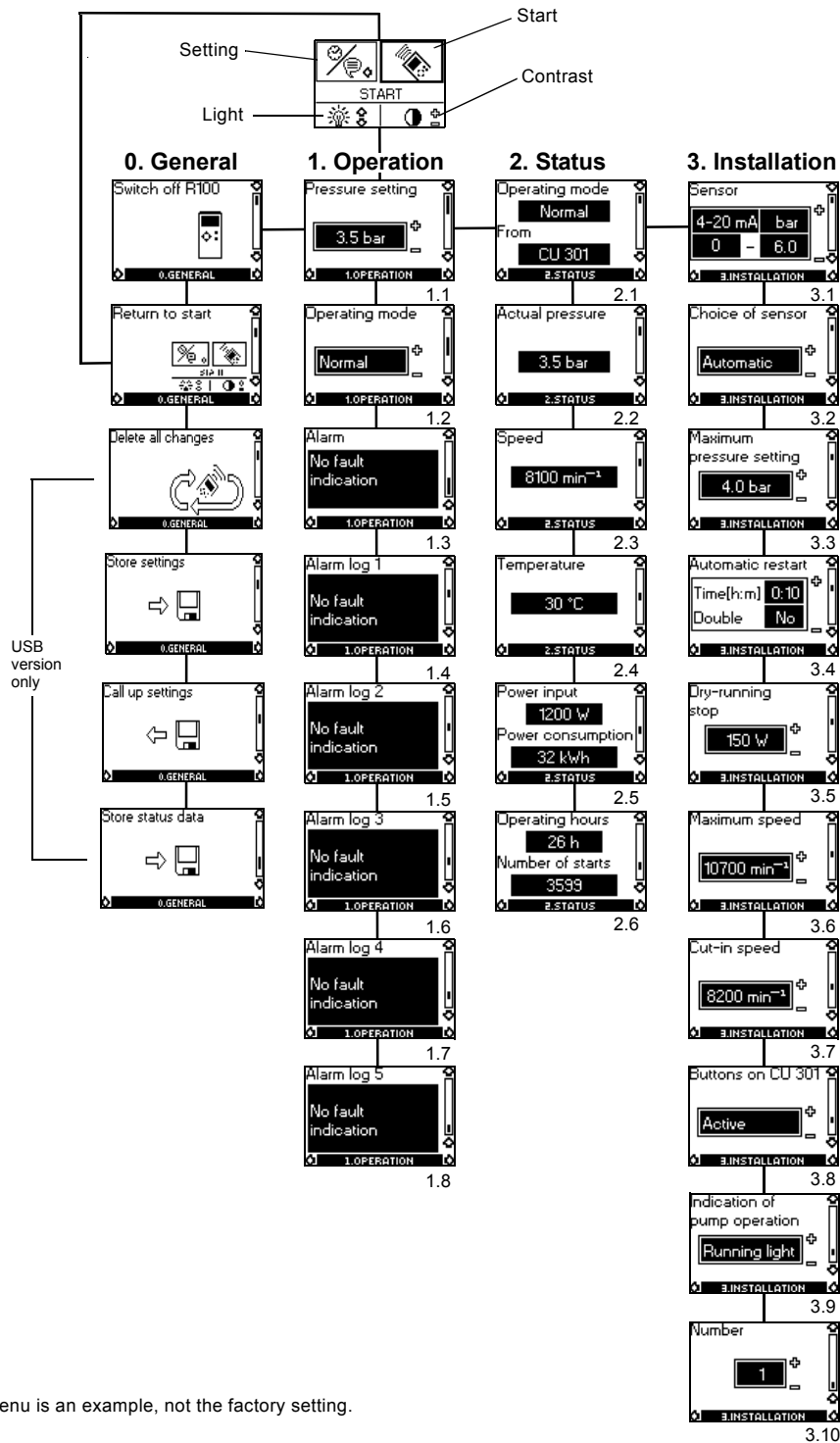

Fig. 17 CU 301 dimensions

TM03 3003 2010

## R100 menu structure for CU 301 control unit



## R100 menus for CU 301

### 0. General

### 1. Operation

- 1.1 Setpoint setting
- 1.2 Selection of operating mode
- 1.3 Alarm indication.

### 2. Status

The indication of:

- 2.1 Actual operating mode
- 2.2 Actual pressure
- 2.3 Actual motor speed
- 2.4 Actual motor temperature
- 2.5 Actual power input and accumulated motor power consumption
- 2.6 Accumulated number of operating hours and accumulated number of starts.

### 3. Installation

- 3.1 Sensor parameters
- 3.2 Choice of sensor
- 3.3 Setting of maximum pressure setpoint
- 3.4 Setting of automatic restart time
- 3.5 Setting of the dry-running stop limit
- 3.6 Setting of the maximum motor speed
- 3.7 Setting of the cut-in motor speed
- 3.8 Activating or deactivating the on/off-button and the buttons for system pressure setting on the CU 301
- 3.9 Indication of pump operation
- 3.10 Allocation of identification number.

## CU 300

The CU 300 is a control and communication unit developed especially for the SQE submersible pumps for control applications other than constant pressure.

The CU 300 control unit provides:

- Flexible pump control based on various sensor inputs
- two-way communication with the SQE pumps
- alarm indication of pump operation by LED's on the front
- possibility of starting, stopping and resetting the pump simply by means of a push-button
- communication with R100 remote control.

The CU 300 communicates with the pump via mains borne signalling (Power Line Communication), meaning that no extra cables are required between the CU 300 and the pump.

The following alarms can be indicated by the CU 300:

- No contact
- overvoltage
- undervoltage
- dry running
- speed reduction
- overtemperature
- overload
- sensor alarm.

The CU 300 incorporates:

- External signal input for two analog sensors and one digital sensor
- relay output for external alarm indication
- control according to the signals received, e.g. of flow, pressure, water level and conductivity.

### R100 remote control

Wireless infrared remote control of the CU 300 is possible by means of the R100.

Using the R100, it is possible to monitor and change the operating parameters, see the R100 menu structure on page 35.

The R100 is a valuable tool in case fault finding is required.

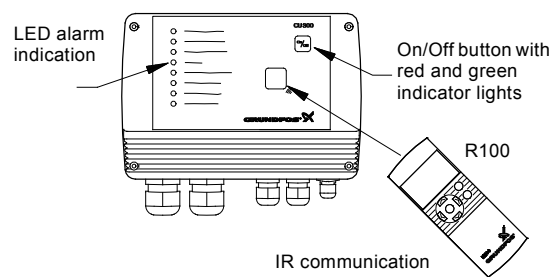

Fig. 18 CU 300 control unit with R100

TM01 2760 4801

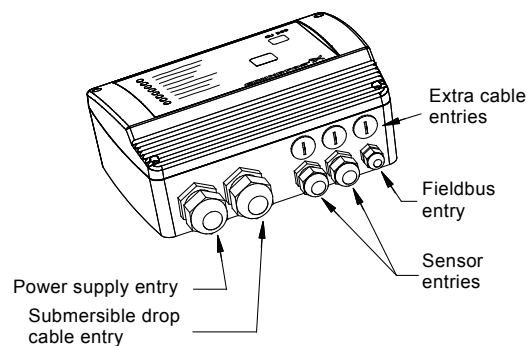

Fig. 19 CU 300 control unit, external entry ports

TM01 2761 4801

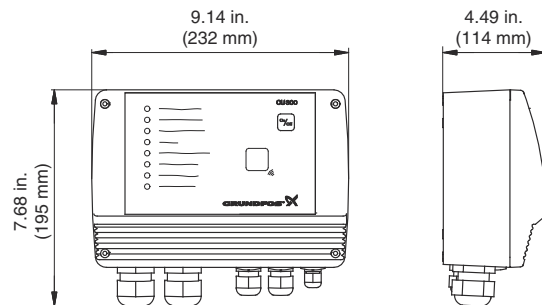
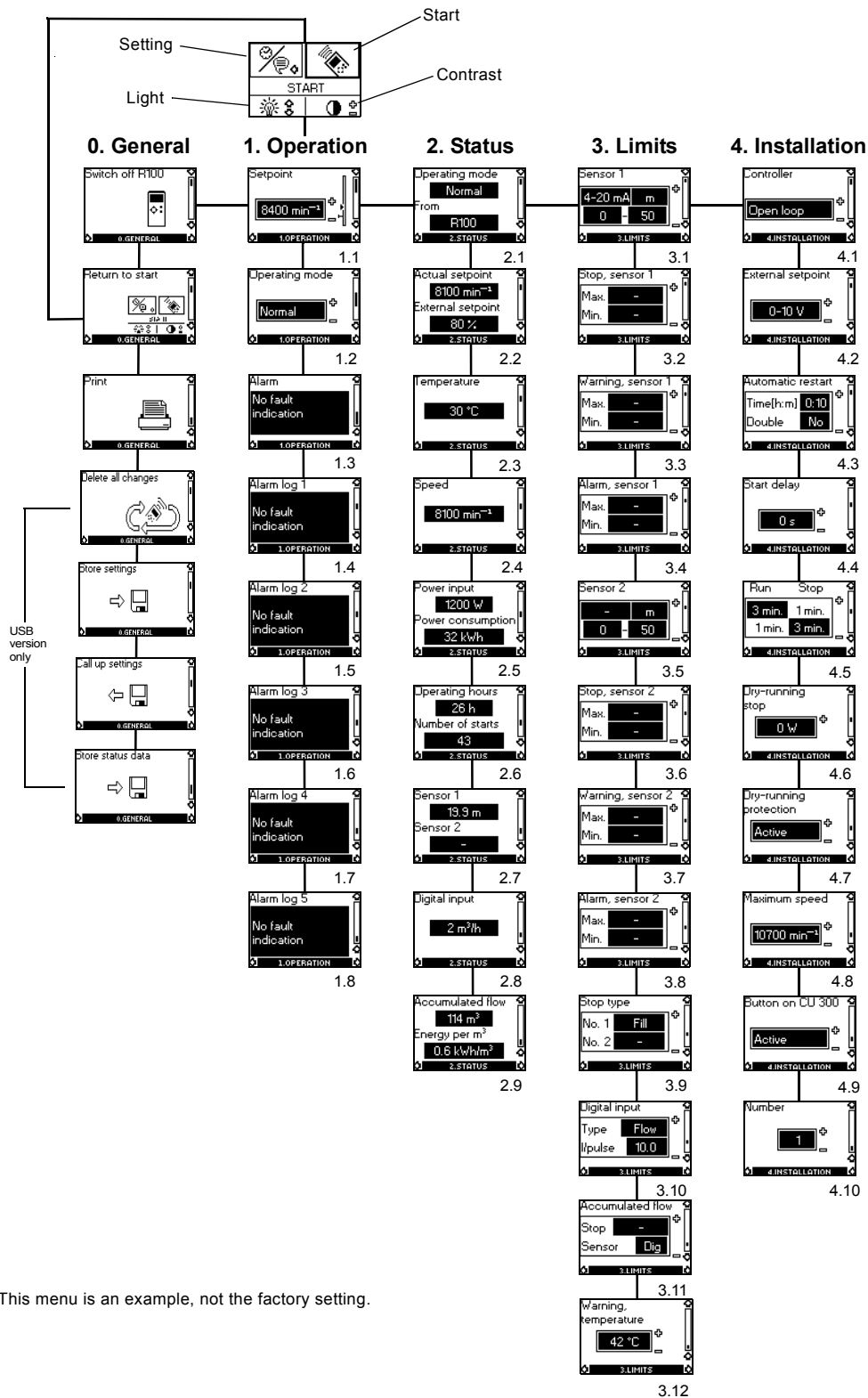

Fig. 20 CU 300 dimensions

TM01 2781 2010

## R100 menu structure for the CU 300



**Note:** This menu is an example, not the factory setting.

## R100 menus for CU 300

### 0. General

### 1. Operation

- 1.1 Setpoint setting
- 1.2 Selection of operating mode
- 1.3 Alarm indication.

### 2. Status

The indication of:

- 2.1 Actual operating mode
- 2.2 Actual and external setpoint
- 2.3 Actual motor temperature
- 2.4 Actual motor speed
- 2.5 Actual power input and accumulated motor power consumption
- 2.6 Accumulated number of operating hours and accumulated number of starts
- 2.7 Actual values of sensors 1 and 2, respectively
- 2.8 Actual values of the digital input
- 2.9 Accumulated flow, and the power used to pump.

R100 offers the possibility of making a number of settings.

### 3. Limits

The setting of:

- 3.1 Sensor 1 parameters
- 3.2 Min. and max. stop limits of sensor 1
- 3.3 Min. and max. warning limits of sensor 1
- 3.4 Min. and max. alarm limits of sensor 1
- 3.5 Sensor 2 parameters
- 3.6 Min. and max. stop limits of sensor 2
- 3.7 Min. and max. warning limits of sensor 2
- 3.8 Min. and max. alarm limits of sensor 2
- 3.9 Filling or emptying
- 3.10 Setting of the function of the digital sensor connected to the digital input
- 3.11 The setting of the water quantity stop limit and the setting of the sensor to detect water quantity
- 3.12 The setting of the temperature warning limits of the motor electronics.

### 4. Installation

- 4.1 Selection of controller — open loop, closed loop
- 4.2 Setting of external setpoint
- 4.3 Setting of automatic restart time
- 4.4 Allocation of individual start delays
- 4.5 Setting of the stop and run times for the dewatering function
- 4.6 Setting of the dry-running stop limit
- 4.7 Activating or deactivating the dry-running protection
- 4.8 Setting of the maximum motor speed
- 4.9 Activating or deactivating the on/off-button on the CU 300
- 4.10 Allocation of ID number where more than one CU 300 is installed.

## Examples of R100 displays

### Menu OPERATION

#### Setpoint setting

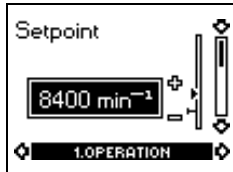

1.1

From factory, the pump is set to maximum speed, 10,700 rpm. R100 makes it possible to reduce the pump speed by changing the setpoint. The speed can be set to 3,000 - 10,700 rpm, at 100 rpm intervals.

The unit of the setpoint is automatically changed according to the unit of the sensor connected to sensor input 1.

**Example:** Sensor input 1 is connected to a pressure sensor using the unit feet (ft) and the range 0-60. Consequently, the setpoint of display 1.1 can be set to between 0-60 ft.

### Menu STATUS

The displays appearing in this menu are status displays only. It is not possible to change settings in this menu.

#### Accumulated flow

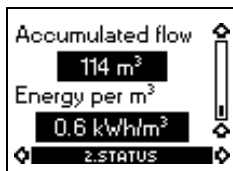

2.9

In display 2.9, the water quantity (m<sup>3</sup>)\* pumped is shown. The value shown is the accumulated flow registered by the sensor selected in display 3.11.

The power used to pump 1 m<sup>3</sup> is shown in the display as energy per m<sup>3</sup> (kWh/m<sup>3</sup>).

It is possible to read the status of the accumulated flow and energy per m<sup>3</sup> at any time.

\*Water quantity in units of gpm can be chosen.

#### Accumulated number of operating hours and number of starts



2.6

The number of operating hours and the number of starts are values accumulated from the time of installation and they cannot be reset.

Both values are stored in the motor electronics, and they are kept even if the CU 300 is replaced.

The number of operating hours is registered every two hours of continuous operation.

### Menu LIMITS

#### Sensor 1

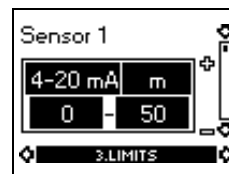

3.1

The setting of sensor 1.

Depending on the type of sensor, the following settings can be made:

- Sensor outputs:
  - (not active), 0-10 V, 2-10 V, 0-20 mA, 4-20 mA
- setting range unit: m<sup>3</sup>/h, m, %, gpm, ft
- sensor minimum value: 0-249 (0, 1, 2, 3.....249)
- sensor maximum value: 1-250 (1, 2, 3, 4.....250).

## CU 321 variable frequency drive

### Features

- Complete solution from one manufacturer
- Easy setup: simply select pump model and choose pressure setpoint
- Four pump choices: offered in most popular sizes, both 3 and 5 hp: 15, 25, 40, and 75 gpm
- Matched pump and motor: 3 hp pump on 3 hp motor and 5 hp pump on 5 hp motor
- Respects original operating designs; operates pump and motor within its designed rpm and hp ratings
- Built-in protection features: soft-start, dry run, overload, over / under voltage, sensor alarm
- Wide voltage range:  
3 hp unit:  
Single or 3-phase 208-240 VAC (+/-10 %)  
5 hp input:  
Single or 3-phase 208-240 VAC (+/-10 %).

### Applications

For 4" or larger wells. Main applications:

- Domestic and light commercial water supply
- irrigation
- livestock watering
- water transfer.

### Components

- Compact, efficient, and reliable CU 321 variable frequency drive
- rugged stainless steel pump end and proven, reliable, 3-phase 230V motor
- pressure sensor
- minimum 4 gal diaphragm tank (sold separately).



TM04 7510 2110

Fig. 21 CU 321 variable frequency drive and sensor

### Sizing

#### Step 1

Calculate maximum head requirements at rated flow conditions:

$$H_{\max} = \text{dynamic head} + \text{system psi (in feet)} + \text{friction loss} + \text{above grade elevation.}$$

#### Step 2

Select pump from System Sizing Matrix as follows:

Select a model in which the calculated value of  $H_{\max}$  is below the value in Column 2.

#### Example

The choice for a 40 gpm model with an  $H_{\max}$  of 150 would be the 40S30-9.

System sizing matrix		
Pump type	Column 1	Column 2
	Shutoff head (0 gpm) @ 1500 rpm min. speed	Head @ rated gpm @ 3600 rpm max. speed
3 hp	TDH [ft]	TDH [ft]
16S30-24	128	490
25S30-15	80	305
40S30-9	45	185
75S30-5	30	105
5 hp		
16S50-38	200	825
25S50-26	105	530
40S50-15	75	310
75S50-8	45	175

# CU 321 variable frequency drive

SQ, SQE, SQE-NE, CU 321

## Performance curves - CU 321 variable speed

16 gpm - Model 16S30-24

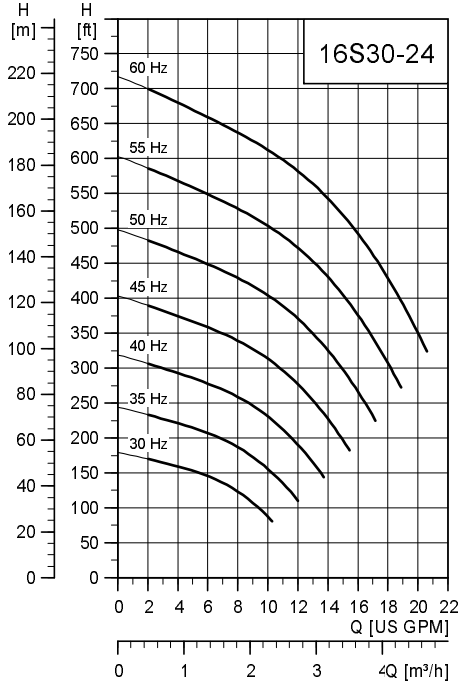

TM04 7523 2110

25 gpm - Model 25S30-15

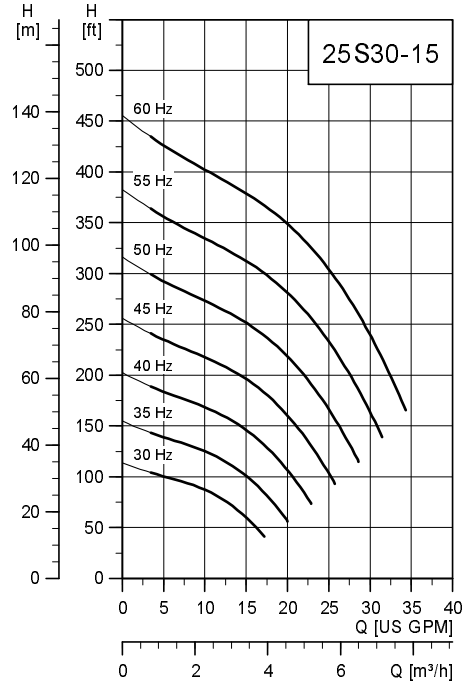

TM04 7525 2110

16 gpm - Model 16S50-38

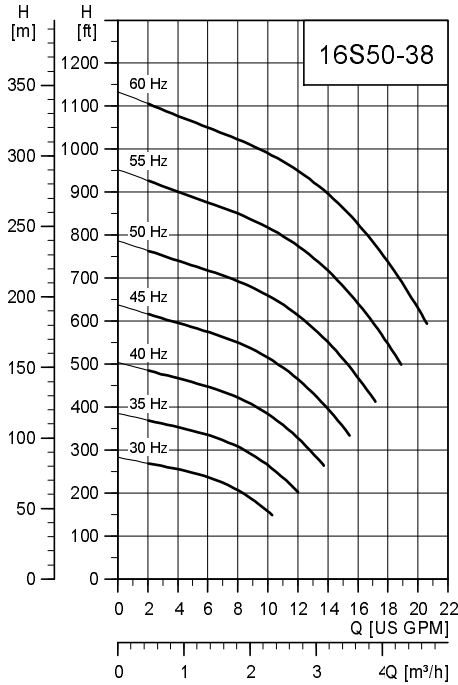

TM04 7524 2110

25 gpm - Model 25S50-26

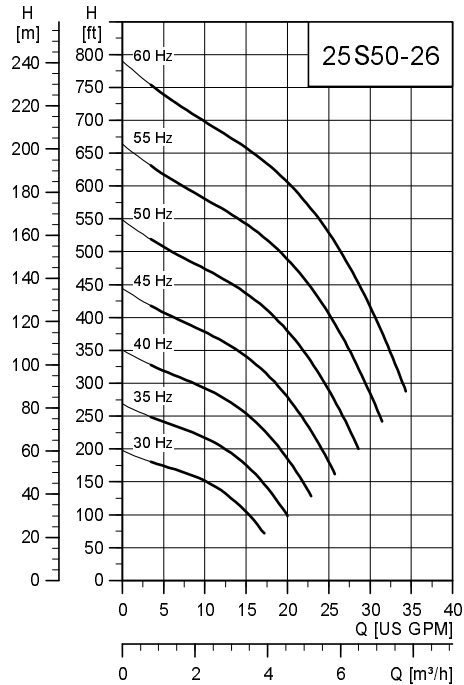

TM04 7526 2110

# CU 321 variable frequency drive

SQ, SQE, SQE-NE, CU 321

40 gpm - Model 40S30-9

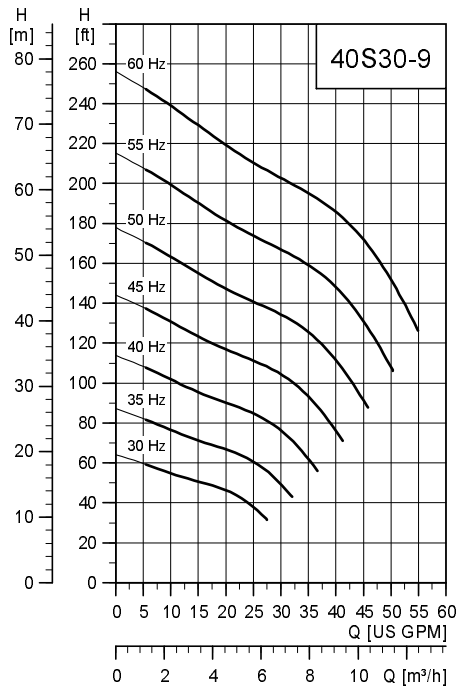

TM04 7527 2110

75 gpm - Model 75S30-5

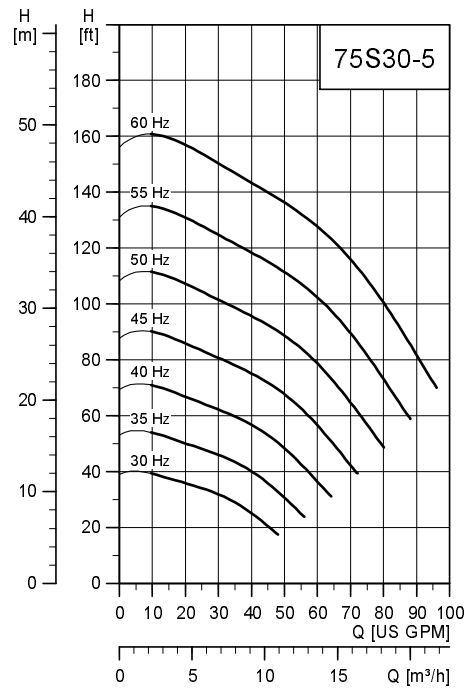

TM04 7530 2110

40 gpm - Model 40S50-15

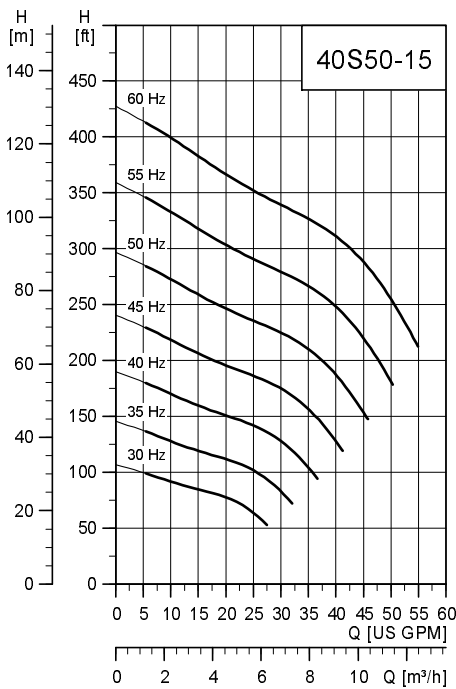

TM04 7529 2110

75 gpm - Model 75S50-8

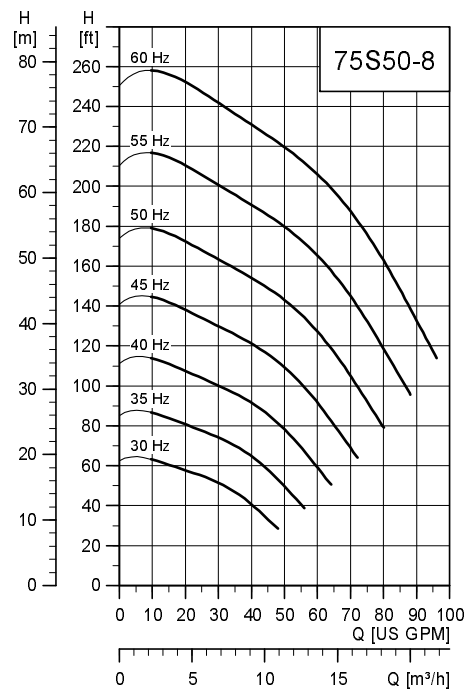

TM04 7531 2110

## CU 321 variable frequency drive



TM04 7510 2110

Description	Hp	Input Ph	Input volts	Product number
CU321 Constant Pressure Kit	3	1	200 - 240	96581690
CU321 Constant Pressure Kit	5	1	200 - 240	96632970
CU321 Constant Pressure Kit	5	3	200 - 240	96581691
Sensor	-	-	-	96437852

Note: Kit includes CU321 and pressure sensor

## CU 301 Constant Pressure System



TM04 7509 2110

Description	Product number
Constant Pressure Kit (CU 301 and Transducer)	96438895

## CU 300 Status Box & R100



TM04 7508 2110

Description	Product number
CU300 Status Box	96422776

Description	Product number
R100 (for wireless infrared communication with the CU 301 / CU 300)	96615297

## SQ, SQE flow sleeves

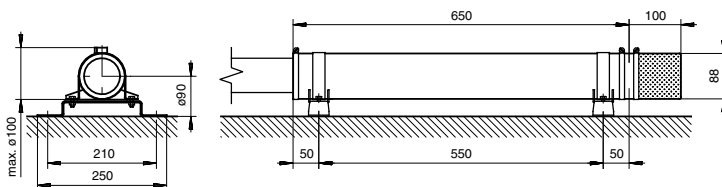

TM01 3292 3798

Description	Product number
SQ, SQE flow sleeve, complete	96037505



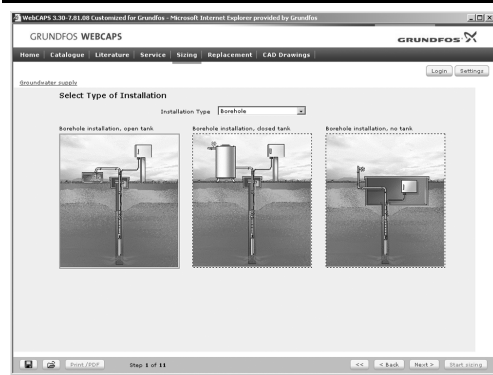

## Sizing

This section is based on different fields of application and installation examples, and gives easy step-by-step instructions in how to

- select the most suitable and efficient pump for your installation
- carry out advanced calculations based on energy consumption, payback periods, load profiles, life cycle costs, etc.
- analyse your selected pump via the built-in life cycle cost tool
- determine the flow velocity in wastewater applications, etc.

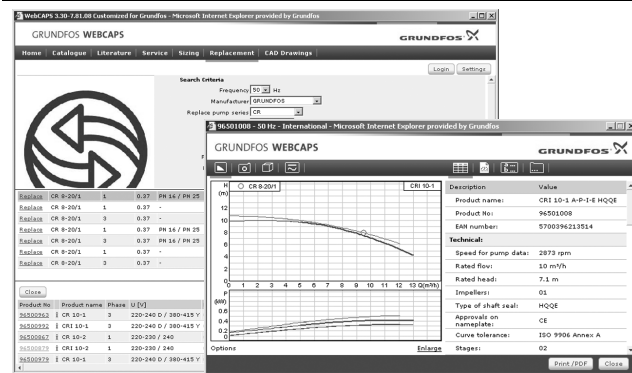

## Replacement

In this section you find a guide to selecting and comparing replacement data of an installed pump in order to replace the pump with a more efficient Grundfos pump. The section contains replacement data of a wide range of pumps produced by other manufacturers than Grundfos.

Based on an easy step-by-step guide, you can compare Grundfos pumps with the one you have installed on your site. When you have specified the installed pump, the guide will suggest a number of Grundfos pumps which can improve both comfort and efficiency.

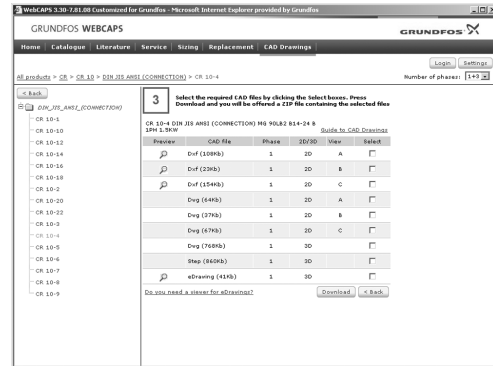

## CAD drawings

In this section it is possible to download 2-dimensional (2D) and 3-dimensional (3D) CAD drawings of most Grundfos pumps.

These formats are available in WebCAPS:

### 2-dimensional drawings:

- .dxf, wireframe drawings
- .dwg, wireframe drawings.

### 3-dimensional drawings:

- .dwg, wireframe drawings (without surfaces)
- .stp, solid drawings (with surfaces)
- .eprt, E-drawings.

## WinCAPS



Fig. 1 WinCAPS CD-ROM

WinCAPS is a **Windows-based Computer Aided Product Selection** program containing detailed information on more than 185,000 Grundfos products in more than 20 languages.

The program contains the same features and functions as WebCAPS, but is an ideal solution if no Internet connection is available.

WinCAPS is available on CD-ROM and updated once a year.









L-SQ-PG-001 0610	US
Repl. 02/06	
© 2006, 2010 Grundfos Pumps Corp.	

The name Grundfos, the Grundfos logo, and the payoff Be-Think-Innovate are registered trademarks owned by Grundfos Management A/S or Grundfos A/S, Denmark. All rights reserved worldwide.

GRUNDFOS Pumps Corporation  
17100 West 118th Terrace  
Olathe, Kansas 66061  
Phone: +1-913-227-3400  
Telefax: +1-913-227-3500

GRUNDFOS Canada Inc.  
2941 Brighton Road  
Oakville, Ontario L6H 6C9 Canada  
Phone: +1-905 829 9533  
Telefax: +1-905 829 9512

Bombas GRUNDFOS de Mexico S.A. de C.V.  
Boulevard TLC No. 15  
Parque Industrial Stiva Aeropuerto  
Apodaca, N.L. Mexico 66600  
Phone: +52-81-8144 4000  
Telefax: +52-81-8144 4010