

Magna

Series 2000 circulator pumps



Contents

Mission

Product data

MAGNA	4
Duty range	4
Characteristic features	4
Benefits	4
Applications	5
Heating systems	5
Pumped liquids	5
Type key	6
Performance range, MAGNA	6

Product range

Product range	7
Pump selection	7
Pump size	7
Operating conditions	7
Communication	7
Control mode	7

Operating conditions

General recommendations	8
Liquid temperature	8
Ambient conditions	8
Maximum operating pressure	8
Minimum inlet pressure	8
Electrical data	9
Sound pressure level	9

Functions

Functions	10
Control modes (factory setting)	11
AUTOADAPT	11
Additional control and operating modes	11
Proportional-pressure control	11
Constant-pressure control	12
Constant-curve duty	12
Max. or min. curve duty	12
Temperature influence	12
Automatic night-time duty	13
Additional operating modes two pumps in parallel	13
Readings and settings on the pump	13
Communication	14
Digital input	14
Digital output	15
Analog input	15
Bus communication via GENIbus	16
Bus communication via LON	16
Functions of expansion modules	16

Construction

Motor and electronic controller	17
Pump connections	17
Paint	17
Material specification	18

Installation

Mechanical installation	19
Electrical connection	20
Cables	20
Wiring diagram	20
Additional protection	20
Operating modes:	21
Examples of connections	22

Curve conditions

Curve conditions	23
------------------	----

Performance curves/ technical data

MAGNA 65-60 F	24
MAGNA 40-120 F	26
MAGNA 65-120 F	28

Accessories

Packaged fitting sets	30
Insulation kits	30
Expansion modules for MAGNA	31
GENI module	31
LON module	32
R100	32

Order data

MAGNA, cast iron	33
MAGNA, stainless steel	33

Further product documentation

WebCAPS	34
WinCAPS	35

- to successfully develop, produce, and sell high quality pumps and pumping systems worldwide, contributing to a better quality of life and healthier environment



Bjerringbro, Denmark



Fresno, California



Olathe, Kansas



Monterrey, Mexico



Allentown, Pennsylvania



Oakville, Ontario

- One of the 3 largest pump companies in the world
- The second largest manufacturer of submersible motors in the world
- World headquarters in Denmark
- North American headquarters in Kansas City - Manufacturing in Fresno, California
- 73 companies in 41 countries
- More than 10 million motors and pumps produced annually worldwide
- North American companies operating in USA, Canada and Mexico
- Continuous reinvestment in growth and development enables the company to **BE** responsible, **THINK** ahead, and **INNOVATE**

MAGNA

The MAGNA ranges of circulator pumps are specially designed for

- heating systems
- domestic hot-water systems (stainless-steel pump housing).

Duty range

Data	MAGNA
Maximum flow, Q	170 GPM
Maximum head, H	42 ft
Maximum system pressure	175 PSI (12 bar, 1.2 MPa)
Liquid temperature	+50 to +230°F *(+15 to +110°C.)



GR8384

Fig. 1 MAGNA pump

Characteristic features

- AUTOADAPT
- proportional-pressure duty
- constant-pressure duty
- constant-curve duty
- max. or min. curve duty
- parallel connection of two pumps (requires additional expansion module).
- no external motor protection required.

Benefits

- low noise level
- safe selection
- simple installation
- low energy consumption, all MAGNA pumps are high efficiency with permanent magnet (PM) motors. Energy class "A" in European energy labeling schedule.
- in addition to this, the AUTOADAPT function ensures energy savings for MAGNA pumps
- long life and no maintenance
- external control and monitoring enabled via optional expansion modules.

Applications

Heating systems

- Main loop
- Mixing loops
- Heating surfaces.

The MAGNA circulator pumps are designed for circulating liquids in heating systems with variable flows where it is desirable to optimize the setting of the pump duty point. The pumps are also suitable for domestic hot-water systems.

To ensure correct operation, it is important that the sizing range of the system falls within the duty range of the pump.

The MAGNA is especially suitable for installation in existing systems where the differential pressure of the pump is too high in periods with reduced flow demand. The pump is also suitable for new systems where automatic adjustment of pump head to actual flow demand is required without using expensive bypass valves or the like.

Furthermore, the pump is suitable for application in systems with hot-water priority where an external contact can immediately force the pump to operate according to the max. curve.

Pumped liquids

Thin, clean, non-aggressive and non-explosive liquids, not containing any solid particles, fibers or mineral oil.

If the pump is installed in a heating system, the water should meet the requirements of accepted standards on water quality in heating systems.

In domestic hot-water systems, the pump should be used only for water with a degree of hardness lower than 17 grains/gallon (14°dH). The pump must **not** be used for the transfer of flammable liquids such as diesel oil and petrol.

If the pump is not used during periods of frost, necessary steps must be taken to prevent frost bursts. Additives with a density and/or kinematic viscosity higher than those/ that of water will reduce the hydraulic performance.

Whether a pump is suitable for a particular liquid, depends on a number of factors of which the most important are lime content, pH value, temperature and content of solvents, oils, etc.

Type key

MAGNA

Example	MAGNA	40	-120	(F)	(N)	280
MAGNA						
Nominal diameter of suction and discharge ports (mm)						
Maximum head [dm]						
Flange connection						
N: Single-head pump housing of stainless steel						
Port-to-port [mm]						

Performance range, MAGNA

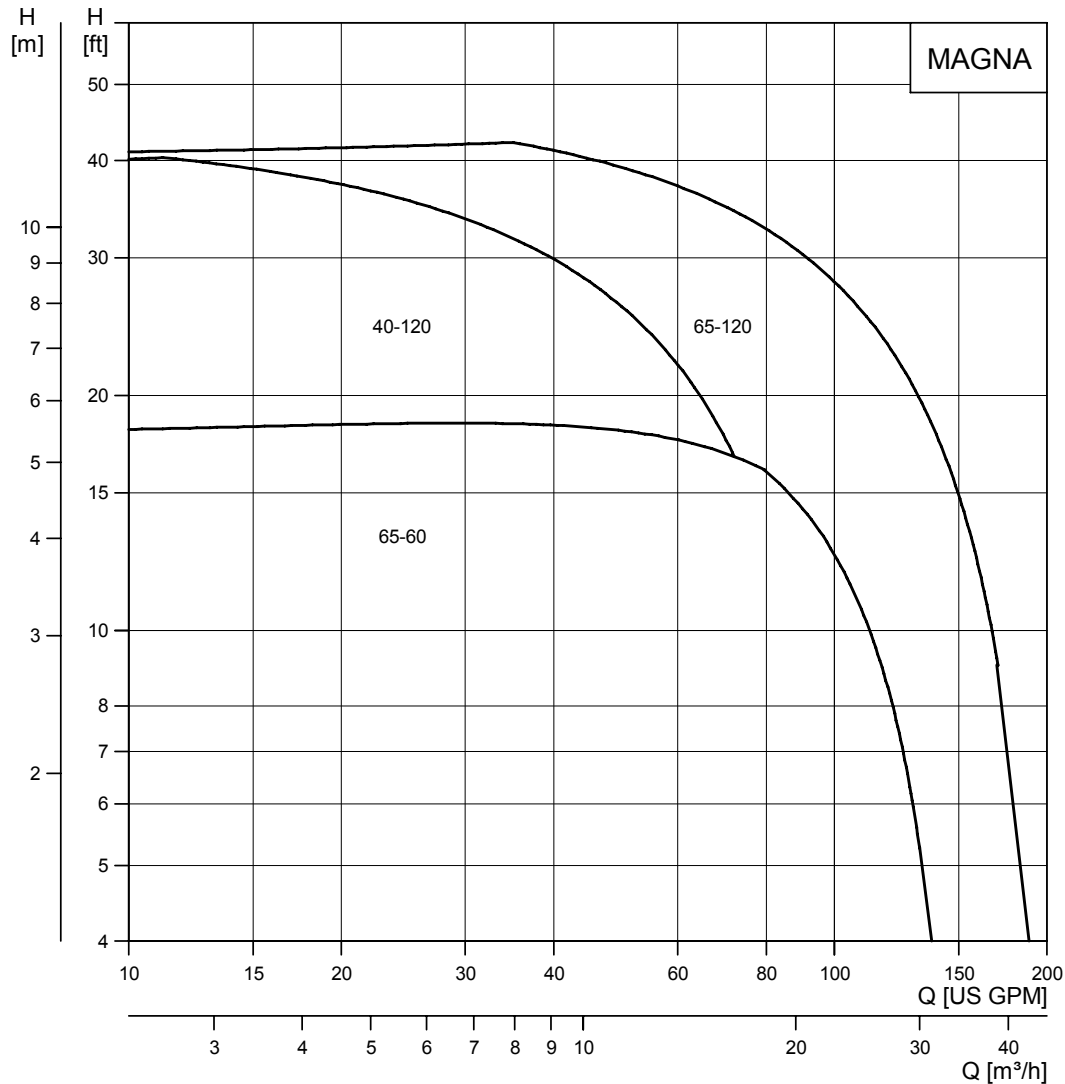

Fig. 2 Performance range

TM03 8795 2507

Product range

Pump type	Supply voltage	Port-to-port length		Nominal pipe connection		Flange connection		
	1 x 230 V	[inch]	[mm]	1.5"	2.5"	GF15/26	GF 40/43	GF 53
MAGNA 40-120 F (N)	●	8 ½	216	●		●	●	
MAGNA 65-60 F (N)	●	11 ½	292		●			●
MAGNA 65-120 F (N)	●	11 ½	292		●			●

Pump selection

Pump size

Selection of pump size should be based on

- required maximum flow and
- maximum head loss in the system.

Operating conditions

The operating conditions should be within published pump limits. When selecting a MAGNA pump following limitations shall be considered

- liquid temperature and ambient conditions
- minimum inlet pressure
- maximum operating pressure.

Communication

The requirements for external control or monitoring of the pump should be considered, such as access to

- speed control of pump or change of setpoint
- reading of pump data
- start/stop, fault indication or forced control to max. or min. curve.

Control mode

In general, Grundfos recommends

- the factory setting which is suitable for most installations
- proportional-pressure control in systems with relatively great head losses
- constant-pressure control in systems with relatively small head losses.

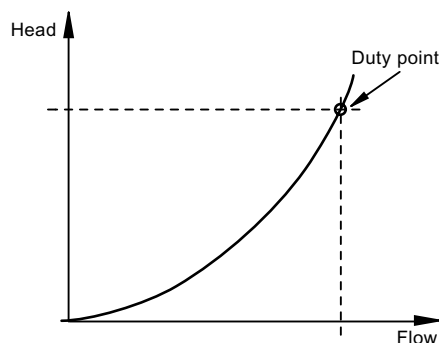

Fig. 3 Performance curve

TM02 2040 3301

General recommendations

MAGNA	
Water in heating systems	Water quality according to local standards.
Domestic hot water	Degree of hardness up to 17 grains/gallon (14 d°H).
Water containing glycol	Max. 50% glycol. Viscosity $\leq 0.3785 \text{ ft}^2/\text{hr}$ (10 mm ² /s).

Liquid temperature

Application	Time	MAGNA
General	Short periods	230°F (+110°C)
	Continuously	59 to 203°F (15 to 95°C)
Domestic hot-water systems	Continuously	59 to 140°F (15 to 60°C)

To avoid condensation in the terminal box and the stator, the liquid temperature must always be higher than the ambient temperature.

Ambient conditions

Ambient temperature during operation	32 to 104 °F (0 to 40 °C)
Ambient temperature during storage/transport	-40 to 140 °F (-40 to 60 °C)
Relative air humidity	Maximum 95 %.

Maximum operating pressure

175 psi (12 bar, 1.2 MPa).

Minimum inlet pressure

The following relative minimum pressures must be available at the pump inlet during operation:

Pump type	Liquid temperature	
	167 °F/75 °C	194 °F/90 °C
Inlet pressure [psi/bar]		
MAGNA 40-120 F	13.1/0.9	17.5/1.2
MAGNA 65-60 F	13.1/0.9	17.5/1.2
MAGNA 65-120 F	13.1/0.9	17.5/1.2

Note: Actual inlet pressure + pump pressure against a closed valve must be lower than the maximum permissible system pressure.

Electrical data

MAGNA

Pump type	Single-phase MAGNA, 40-120, 65-60, 65-120
Enclosure class	IP 44 (IEC 85)
Insulation class	F
External start/stop input	External potential-free switch. Screened cable. Maximum contact load: 5 V, 10 mA.
Setpoint signals	GENI module ★
Signal output	Internal potential-free changeover contact. Screened cable. Maximum contact load: 250 VAC, 2 A. Minimum contact load: 5 VDC, 1 mA.
Bus input	GENI module ★ LON module ★
Supply voltage	1 x 230 V +/-10 %, 50/60 Hz, PE The pump requires no external motor protection.
Earth leakage current	$I_{leak} < 3.5 \text{ mA}$ The leakage currents are measured in accordance with EN 60355-1.
EMC	EN 61800-3.

★ Expansion module

Sound pressure level

Pump type	Single-phase MAGNA, 40-120, 65-60, 65-120
Sound pressure level	≤ 54 dB(A)

Functions

Single-phase MAGNA, 40-120, 65-60, 65-120	
Control modes (factory setting)	
AUTO _{ADAPT}	●
Proportional-pressure control	
Additional control and operating modes	
Proportional-pressure control	●
Constant-pressure control	●
Constant-curve duty	●
Max. or min. curve duty	●
Automatic night-time duty	●
Additional operating modes for two pumps in parallel	
Alternating operation	○
Standby operation	○
Readings and settings on the pump	
Operating indication	●
Flow indication	●
Setpoint	●
Control mode	●
Fault indication	●
Communication	
Wireless remote control, R100	●
External digital input/output	○
External analog input	○
Bus via GENIbus protocol, RS-485	○
Bus via LonTalk [®] protocol, FTT 10	○

- Function incorporated.
- Expansion module required.

Control modes (factory setting)

The pumps have been factory-set to

- *AUTOADAPT*.

The setpoint is factory-set to approximately half of the maximum pump head.

The factory setting is suitable for most installations.

AUTOADAPT

During operation, the pump automatically reduces the factory-set setpoint and adjusts it to the actual system characteristic.

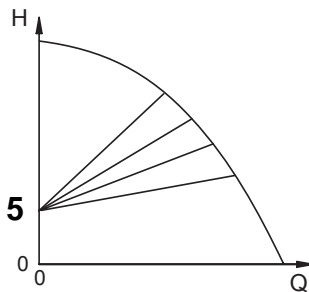

Fig. 4 *AUTOADAPT* control

TM02 0826 0904

Note: Manual setting of the setpoint is not possible.

When the control mode *AUTOADAPT* has been activated, the pump will start at H_{set1} , corresponding to 50 % of its maximum head, and then adjust its performance to A_1 , see fig. 5.

When the pump registers a lower pressure on the max. curve, A_2 , the *AUTOADAPT* function automatically selects a correspondingly lower control curve, H_{set2} .

If the radiator valves close, the pump adjusts its performance to A_3 .

- A_1 : Original duty point.
- A_2 : Lower registered pressure on the max. curve.
- A_3 : New duty point after *AUTOADAPT* control.
- H_{set1} : Original setpoint setting.
- H_{set2} : New setpoint after *AUTOADAPT* control.
- $H_{fac.}$: MAGNA xx-60: 11.5 ft.
MAGNA xx-120: 23 ft
- H_{auto_min} : A fixed value of 5 ft.

The *AUTOADAPT* control mode is a form of proportional-pressure control where the control curves have a fixed origin, H_{auto_min} .

The *AUTOADAPT* control mode is developed specifically for heating applications .

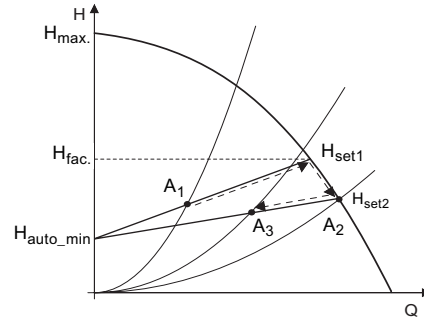

Fig. 5 *AUTOADAPT*

TM03 1071 4005

Additional control and operating modes

Grundfos offers additional control and operating modes to meet specific demands.

The functions available depend on the pump type and the expansion module chosen, see overview of functions on page 10.

Proportional-pressure control

The pump head is changed continuously in accordance with the flow demand in the system.

The head against a closed valve is half the setpoint.

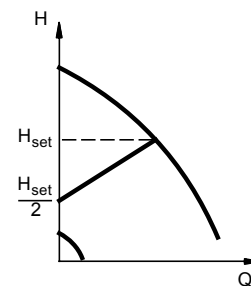

Fig. 6 Proportional-pressure control

The proportional-pressure control is recommended in systems with relatively great head losses.

TM00 4488 0995

Constant-pressure control

The pump head is kept constant, independent of the water requirement.

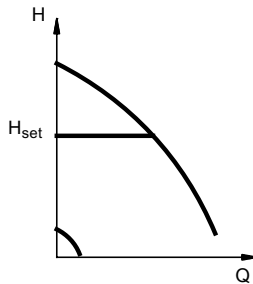

TM00 4489 0995

Fig. 7 Constant-pressure control

The constant-pressure control is recommended in systems with relatively small head losses.

Constant-curve duty

Requires the use of an R100 remote control.

The pump can be set to operate according to a constant curve like an uncontrolled pump.

If an external controller is installed, the pump is able to change from one constant curve to another, depending on the value of the external signal.

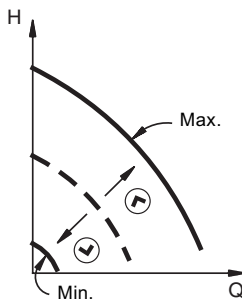

TM03 0551 0205

Fig. 8 Constant-curve duty

Max. or min. curve duty

The pump can be set to operate according to the max. or min. curve, like an uncontrolled pump.

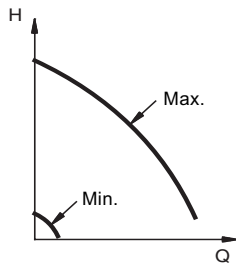

TM00 5547 4596

Fig. 9 Max. or min. curves

The **max. curve** mode can be used in periods in which a maximum flow is required. This operating mode is for instance suitable for hot-water priority.

The **min. curve** mode can be used in periods in which a minimum flow is required. This operating mode is for instance suitable for manual night-time duty.

Temperature influence

Temperature influence function is available with constant and proportional control mode.

To be set with the R100 remote control.

When temperature influence function is activated the setpoint for head will be reduced according to the liquid temperature.

The temperature influence limits can be set to 120°F (50°C) or 175°F (80°C). The temperature limits are not adjustable.

These temperature limits are called T_{max}. The setpoint is reduced in relation to the head set (= 100%) according to the characteristics below.

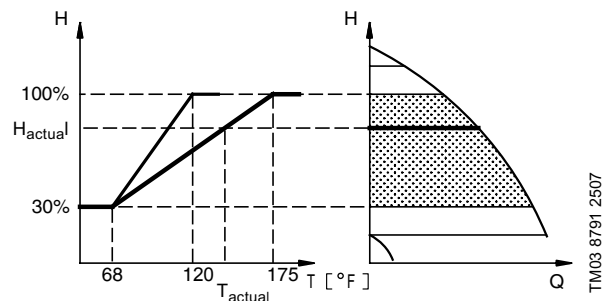

TM03 8791 2507

Fig. 10 Temperature influence

In the above example, T_{max} = 175°F (80°C) has been selected. The actual liquid temperature T_{actual} causes the setpoint for head to be reduced from 100% to H_{actual}.

The temperature influence function requires:

- Proportional- or constant-pressure control mode.
- The pump must be installed in the supply side pipe.
- System with supply pipe temperature control.

Temperature influence is suitable in:

- systems with variable flows (e.g. two-pipe heating systems), in which the activation of the temperature influence function will ensure a further reduction of the pump performance in periods with small heating demands and consequently a reduced supply pipe temperature.
- systems with almost constant flows (e.g. one-pipe heating systems and radiant floor heating systems), in which variable heating demands cannot be registered as changes in the head as is the case with two-pipe heating systems. In such systems, the pump performance can only be adjusted by activating the temperature influence function.

Selection of Tmax.

In systems with a supply pipe temperature of:

- up to and including 131°F (55°C), select Tmax. = 120°F (50°C),
- above 131°F (55°C), select Tmax. = 175°F (80°C).

Automatic night-time duty

When automatic night-time duty has been selected, the pump will change automatically between normal duty and night-time duty. Changeover between normal duty and night-time duty takes place as a result of the supply pipe temperature measured by an integrated temperature sensor.

The automatic changeover to night-time duty takes place when the temperature sensor registers a supply pipe temperature drop of more than 18-27°F (10-15°C) within approx. 2 hours. The required temperature drop is a minimum of 18-27°F (10-15°C).

Changeover to normal duty takes place without a time lag when the temperature has increased by approx. 18°F (10°C).

Additional operating modes two pumps in parallel

The following operating modes are available for two pumps in parallel if both pumps are equipped with optional GENI module:

Alternating operation

Pump operation alternates every 24 hours. If the duty pump stops due to a fault, the other pump starts.

Standby operation

One pump operates continuously. In order to prevent seizing-up, the standby pump starts at a fixed frequency (every 24 hours) and runs for a short period. If the duty pump stops due to a fault, the standby pump starts.

Readings and settings on the pump

The control panel on the pump control box/terminal box incorporates the basic functions for readings and settings.

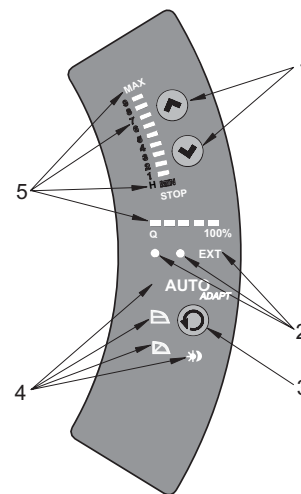

TM03 0379 5004

Fig. 11 MAGNA control panel

Pos.	Description
1	Buttons for setting of head
2	<ul style="list-style-type: none"> • Indicator lights for operating and fault indication and • symbol for indication of external control
3	Button for selection of control mode: <i>AUTOADAPT</i> , proportional pressure, constant pressure and automatic night-time duty
4	Light symbols for indication of control mode and night-time duty
5	Light fields for indication of head, flow and operating mode

Communication

MAGNA pump enables communication via

- wireless remote control, R100
- connection to an external alarm device
- digital input/output
- analog input.

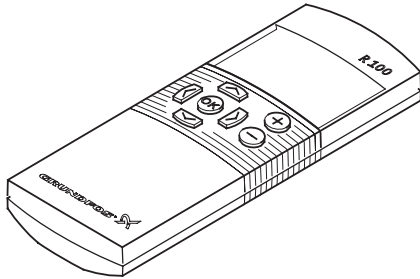

Fig. 12 R100 remote control

MAGNA is designed for wireless communication with the Grundfos R100 remote control.

The R100 offers additional possibilities of setting and status displays for the pump.

The R100 can be used for the following functions:

- reading of operating data
- reading of fault indications
- setting of control mode
- setting of 1/3 ft (0.1 m) head increments
- selection of external setpoint signal
- allocation of pump number making it possible to distinguish between pumps in connection with parallel operation via bus
- selection of function for digital input.

MAGNA has various inputs and outputs for external signals for forced-control functions. Some functions may require an expansion module, see *Expansion modules for MAGNA*.

TM00 4498 2802

Digital input

The function of the digital input is selected with the R100 remote control.

External start/stop

The pump can be started or stopped via the digital input, see fig. 18, terminals 7 and 8.

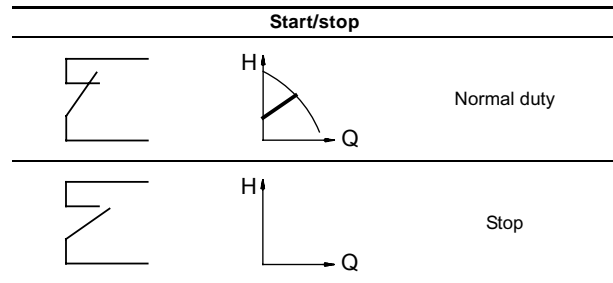

External forced max. or min curve

The pump can be forced to operate on the max. or min. curve via the digital input. Use of the digital input for forced max. or min. curve requires installation of the expansion module, GENI module.

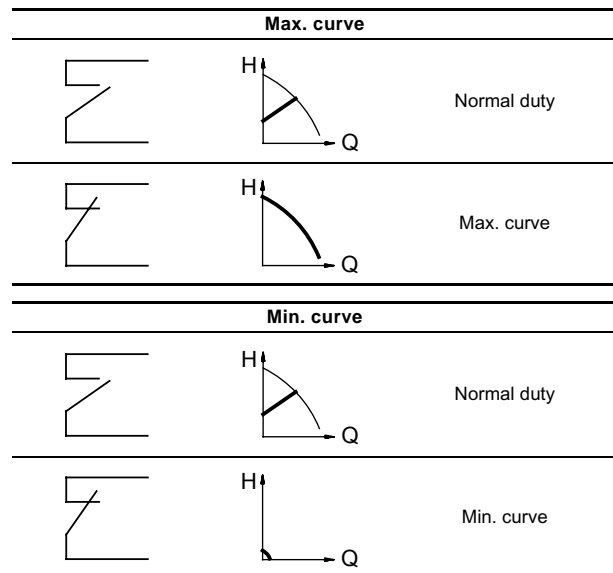

Digital output

The pump incorporates a signal relay with a potential-free changeover contact for external fault indication, see fig. 18, terminals 1 (NC), 2 (NO) and 3 (C).

The function of the signal relay can be changed from "Fault" to "Operating" mode with the R100.

The functions of the signal relay are as shown in the table below:

Signal relay	Fault signal
	<p>Not activated:</p> <ul style="list-style-type: none"> The electricity supply has been switched off. The pump has not registered a fault.
	<p>Activated:</p> <ul style="list-style-type: none"> The pump has registered a fault.
Signal relay	Operating signal
	<p>Not activated:</p> <ul style="list-style-type: none"> The pump has been set to stop. The pump has registered a fault and is unable to run.
	<p>Activated:</p> <ul style="list-style-type: none"> The pump is running. The pump has registered a fault, but is able to run.

Analog input

External analog control

Use of the analog input requires installation of the expansion module, GENI module.

Control of setpoint or speed via an external 0-10 V signal.

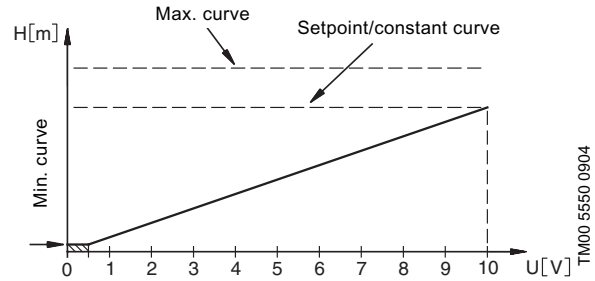

Fig. 13 Example of 0-10 V control

The analog input enables the following control modes:

In **constant-curve mode**, the pump is able to change from one constant curve to another depending on the value of the external signal.

The internal controller is **inactive** in this mode.

In **pressure control mode**, the setpoint can be set externally within the range from the setpoint to the min. curve.

The internal controller is **active** in this mode.

At an input voltage lower than 0.5 V, the pump will operate according to the min. curve.

Bus communication via GENIbus

The bus enables control and monitoring of the pumps from a GRUNDFOS Pump Management System 2000, to a building automation systems (BAS) or another external control system.

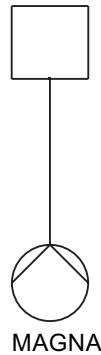

TMO3 2394 4005

Fig. 14 Example of single-pump operation

Pump type	Requires	See section
MAGNA	GENI module	Accessories

Bus communication via LON

Via the bus input and optional LON module the pump can be connected to a network based on LonWorks® technology, and thus be linked to other units based on this communication standard.

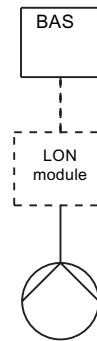

TMO3 8747 2407

Fig. 15 Example of single-pump operation

Functions of expansion modules

Pump type	Inputs/outputs incorporated	With expansion module	Function
MAGNA 40-120 MAGNA 65-60 MAGNA 65-120	Start/stop Signal relay	GENI module	<ul style="list-style-type: none"> • Max. curve • Min. curve • 0-10 V analog input • Control of two pumps in parallel • GENIbus
		LON module	<ul style="list-style-type: none"> • LonTalk® protocol, FTT10

The MAGNA is of the canned-rotor type. The pump and motor form an integral unit without shaft seal and with only two gaskets for sealing. The bearings are lubricated by the pumped liquid.

The pump features are

- controller integrated in the terminal box
- control panel on the terminal box
- terminal box prepared for optional modules
- differential-pressure and temperature detection
- cast-iron or stainless-steel pump housing
- no external motor protection required.

Motor and electronic controller

The **single-phase MAGNA** motor is a 4- or 8-pole, synchronous, permanent-magnet motor (PM motor). This motor type has higher efficiency than a conventional asynchronous squirrel-cage motor.

Pump speed is controlled by an integrated frequency converter.

Pump connections

MAGNA 40-120: Two bolt oval combination flange. Matches GF15/26 and GF 40/43.

MAGNA 65-60 and 65-120: GF53, 4 bolt Non ANSI flange. Can be connected to GF53, 2", 2.5" and , 3" counter flanges.

Paint

Enamel paint.

Color: Grundfos Red (NCS40-50R)

Material specification

MAGNA

Pos.	Component	Material	EN	AISI/ASTM
1	Terminal box	Aluminium/composite		
2	Stator housing	Aluminium AISi 10Cu ₂		
	O-rings	EPDM rubber		
	Outer bearing ring	Aluminium oxide Al ₂ O ₃		
3	Rotor can	Stainless steel	1.4301 or 1.4401	304 or 316
4	Shaft	Stainless steel	1.4401	316
5	Thrust bearing	Carbon MY 106		
	Bearing plate	Stainless steel	1.4301	304
6	Inner bearing ring	Aluminium oxide Al ₂ O ₃		
7	Impeller	Stainless steel	1.4301	304
8	Pump housing	Cast iron or stainless steel	EN-GJL250 1.4308	A48 CL35 CF8

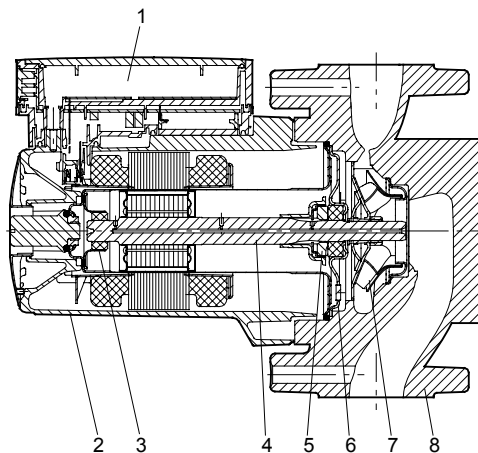

TM02 1256 0801

Fig. 16 MAGNA 40-120, 65-60 and 65-120

Mechanical installation

MAGNA is for indoor installation. The pump shaft shall be installed horizontally.

MAGNA may be installed in horizontal as well as vertical pipes as long as the pump shaft is parallel to the ground. Pump shaft shall not be installed vertically.

Arrows on the pump housing indicate the liquid flow direction through the pump. The liquid flow direction can be horizontal or vertical, depending on the terminal box position.

The terminal box can be turned to various positions. This is described in the installation and operating instructions.

The pump must be installed in such a way that strain from the pipework is not transferred to the pump housing.

The pump may be suspended direct in the pipes, provided the pipework can support the pump. If not, the pump must be installed on a mounting bracket or base plate.

To ensure cooling of motor and electronics, the following must be observed:

- Place the pump in such a way that sufficient cooling is ensured.
- The temperature of the cooling air must not exceed 140°F (40°C.)

Electrical connection

The electrical connection and protection should be carried out in accordance with local regulations.

- The pump must be connected to an external mains switch.
- The pump must always be correctly grounded.
- The pump requires no external motor protection. The motor incorporates thermal protection against slow overloading and blocking (IEC 34-11: TP 211).
- When the pump is switched on via the mains, the pump will start after approx. 5 seconds.

Note: The number of starts and stops via the mains supply must not exceed 4 times per hour.

The pump mains connection must be made as shown in the diagrams on the following pages.

Cables

Use screened cables (0.25-1.5 mm²) for external on/off switch, digital input, sensor and setpoint signals.

- All cables used must be heat-resistant up to at least 185°F (+85°C).
- All cables used must be installed in accordance with NEC, local codes and regulations.

Wiring diagram

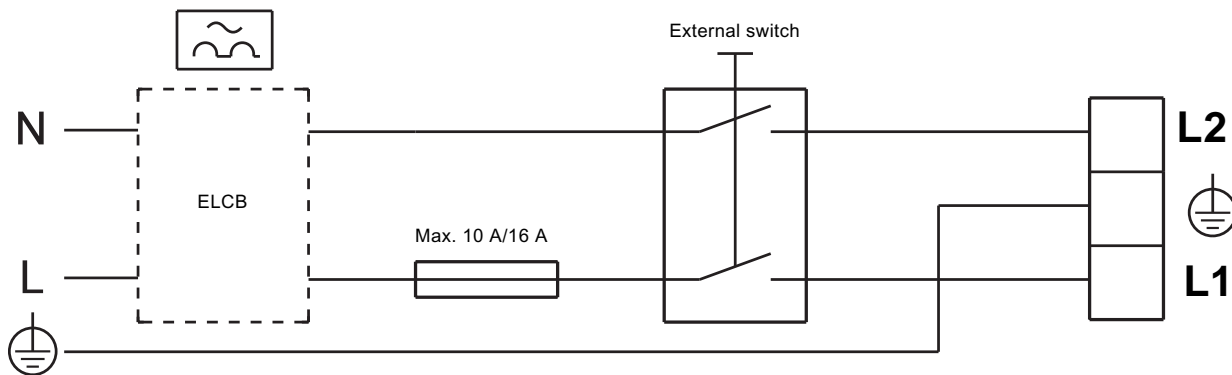

Fig. 17 1 x 230 V +/-10 %, 50/60 Hz

TM03 2397 4005

Additional protection

If the pump is connected to an electric installation where an earth-leakage circuit breaker (ELCB) is used as an additional protection, the earth-leakage circuit breaker must be marked with the following symbols.



The earth-leakage circuit breaker must trip out when earth fault currents with DC content (pulsating DC) occur.

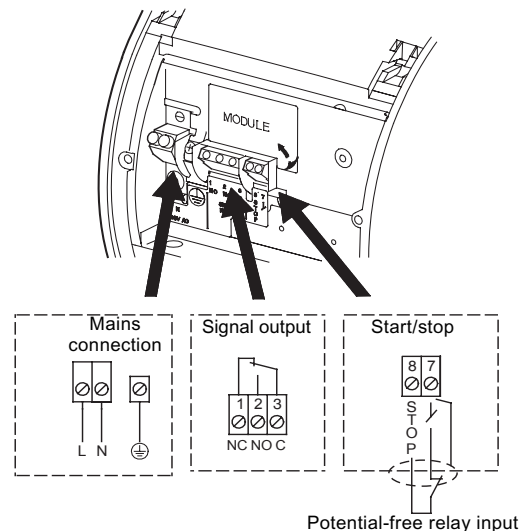

TM02 0235 1007

Fig. 18 MAGNA 40-120, 65-120, 65-60, mains connection

Note: If no external on/off switch is connected, the connection across terminals STOP and \surd should be maintained.

Two pumps in parallel

Two pumps plumbed in parallel can communicate each other with the help of optional GENI module. The modules has to be connected to each other with a wire.

Wiring diagrams:

- Master pump, see fig. 19.
- Slave pump, see fig. 20.

Operating modes:

Alternating operation

Pump operation alternates every 24 hours. If the duty pump stops due to a fault, the other pump will start.

Standby operation

One pump is operating continuously. In order to prevent seizing-up, the other pump will start at a fixed frequency and run for a short period. If the duty pump stops due to a fault, the other pump will start.

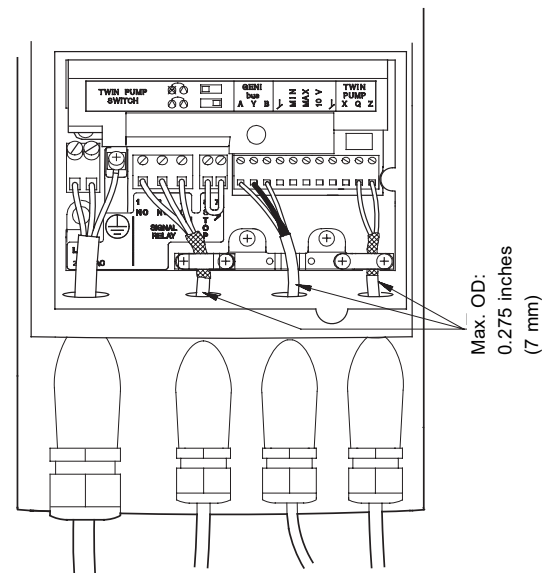
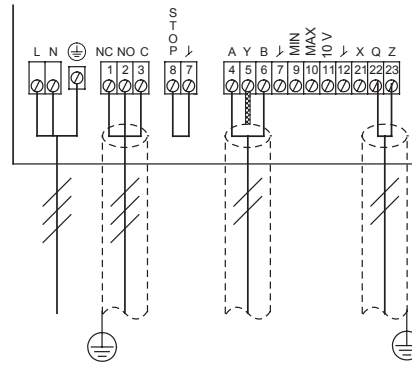

Fig. 20 Two pumps in parallel, slave

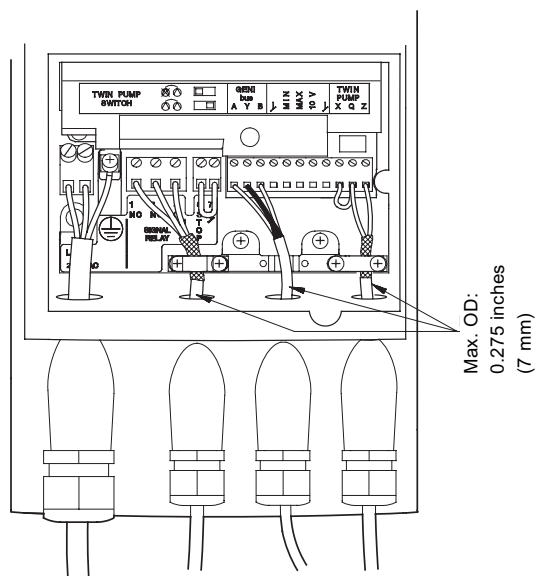
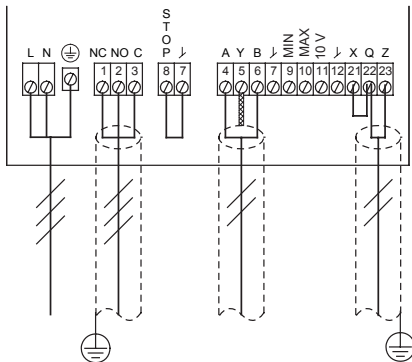

Fig. 19 Two pumps in parallel, master

TM02 0480 1004

TM02 0481 1004

Examples of connections

Connection to external controllers

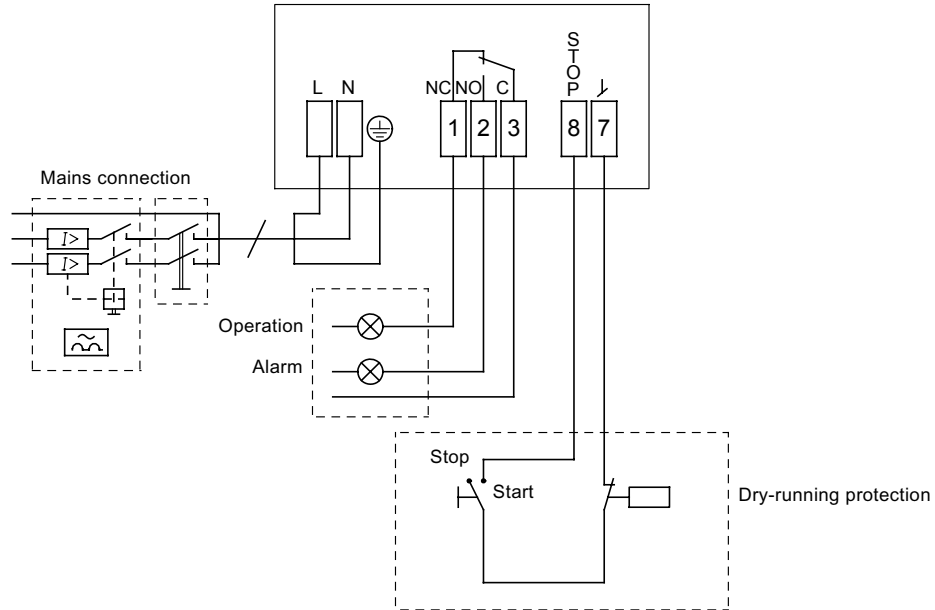

Fig. 21 Example of MAGNA pump

Connection to external controllers

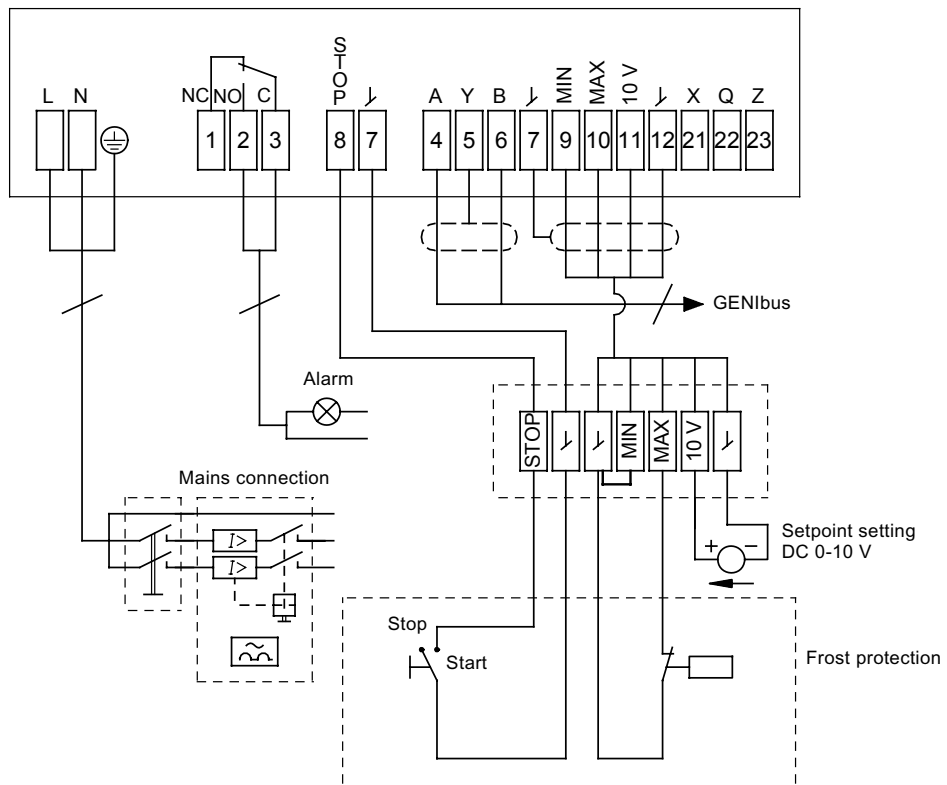

Fig. 22 Example of MAGNA pump with GENI module

TM02 1322 3601

TM02 1323 5101

Curve conditions

The guidelines below apply to the performance curves on pages 23 to 50:

- The **bold** parts of the curves show the **recommended** performance range.
- Test liquid: Airless water.
- All curves show average values and **should not be used as guarantee curves**. If a stated minimum performance is required, individual measurements must be made.
- MAGNA has been tested at 140°F (60°C.)
The conversion between head H [ft] and pressure [psi] has been made for water at 140°F (60°C) SG= 0.983. For liquids with other specific gravities, e.g. hot water, the discharge pressure is proportional to the specific gravities.

The pumps should not be used at a minimum flow rate lying outside the areas indicated by the bold-faced curves due to danger of pump overheating.

Note: Within MAGNA's performance range, the constant- and proportional-pressure curves can be set in steps of 3.3 ft (1 m) head on the control panel and 0.33 ft (0.1 m) head with the R100.

MAGNA 65-60 F

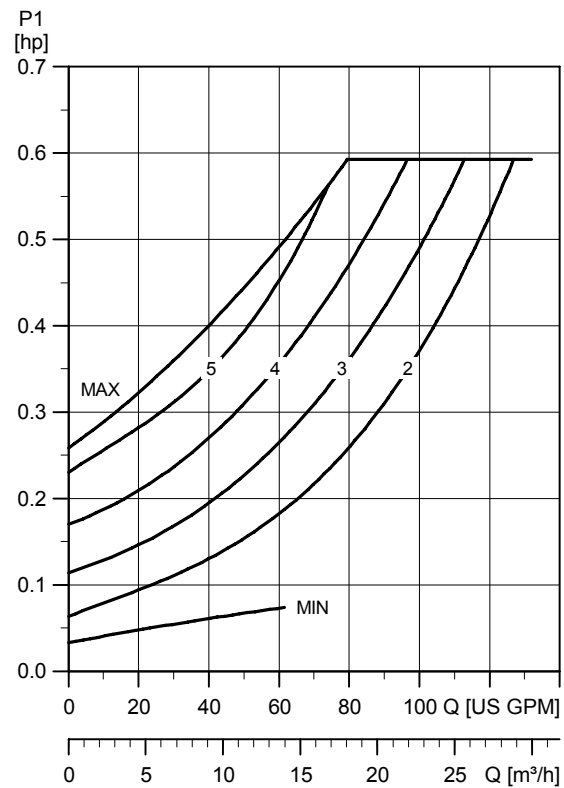
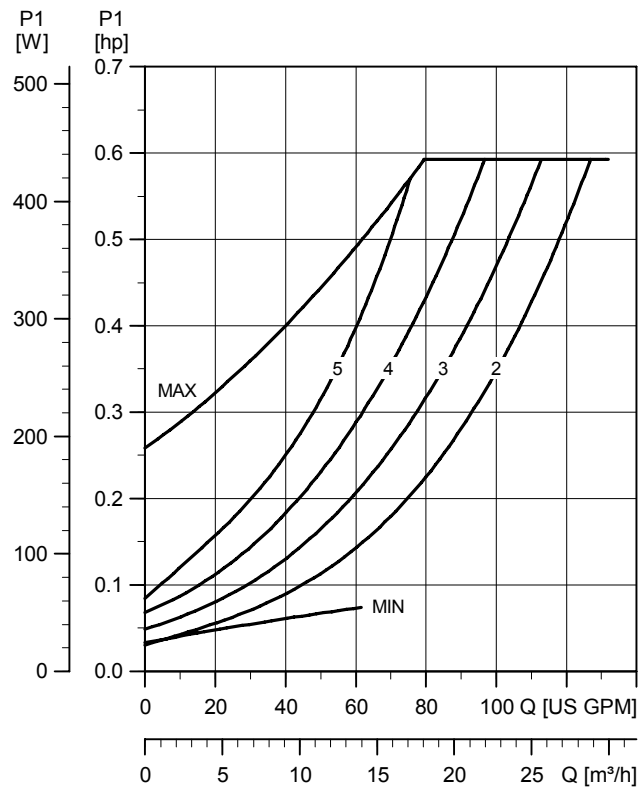
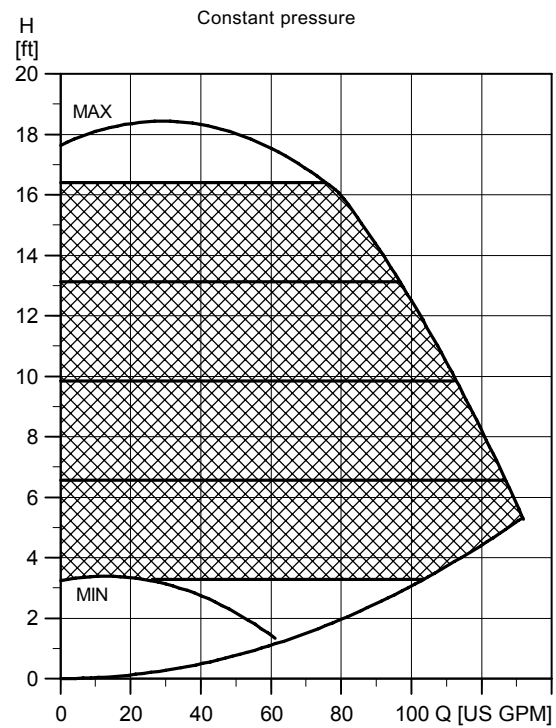
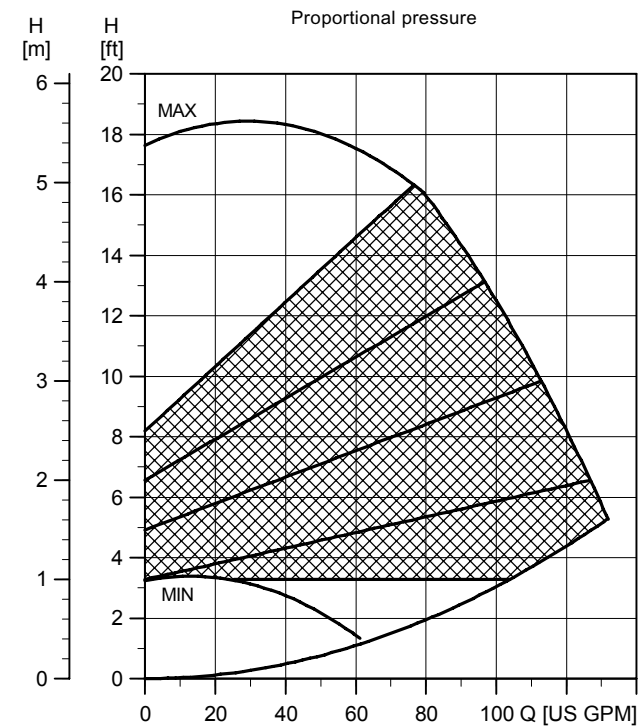

TM03 8792 2507

Performance curves/ technical data

MAGNA 65-60 F

Electrical data

U_n [V]		P_1 [W]	I_{l1} [A]
1 x 230 V	Min.	25	0.17
	Max.	450	2.0

MAGNA 65-60 F is also available with stainless-steel housing, type N.

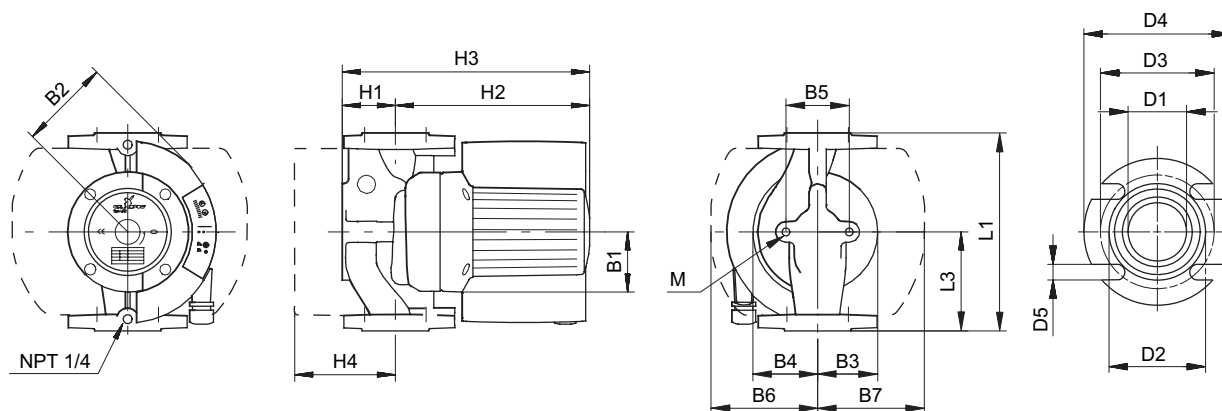

TM03 9058 3307

Dimensions

Pump type	Dimensions [mm]																
	L1	L3	B1	B2	B3	B4	B5	B6	B7	H1	H2	H3	H4	D1	D2	D3	
MAGNA 65-60 F	[in]	11 1/2	5 3/4	3 1/16	4 15/16	3 7/16	4 1/8	3 3/4*	5 1/2	4 5/16	3 1/4	9 15/16	13 1/8	4 3/16	2 1/2	3 15/16	5
	[mm]	292	146	77	125	88	104	96*	140	110	82	252	334	107	63	100	127

Pump type	Dimensions [mm]			
	D4	D5	M	
MAGNA 65-60 F	[in]	6	5/8	M12
	[mm]	152	16	

* Stainless steel pump housing 3 1/8 [in]/80 [mm]

Weights

Pump type	Weights [lb/kg]	
	Net	Gross
MAGNA 65-60 F	48.5/22	53/24

MAGNA 40-120 F

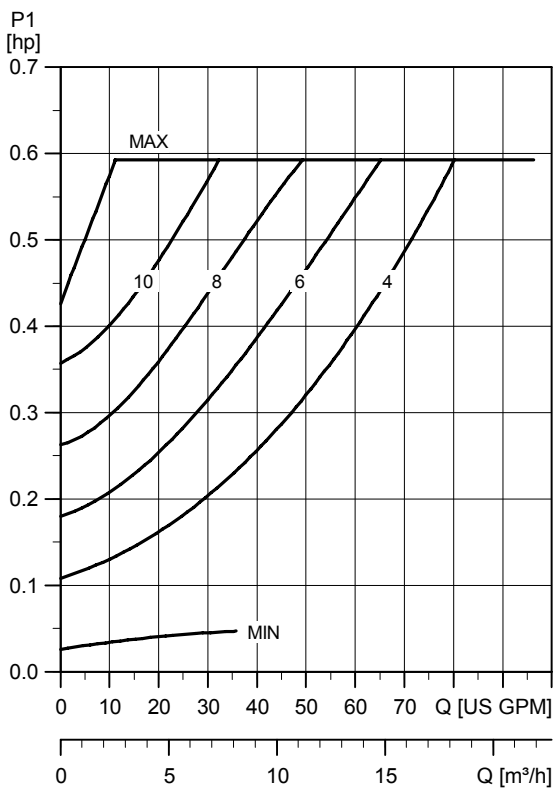
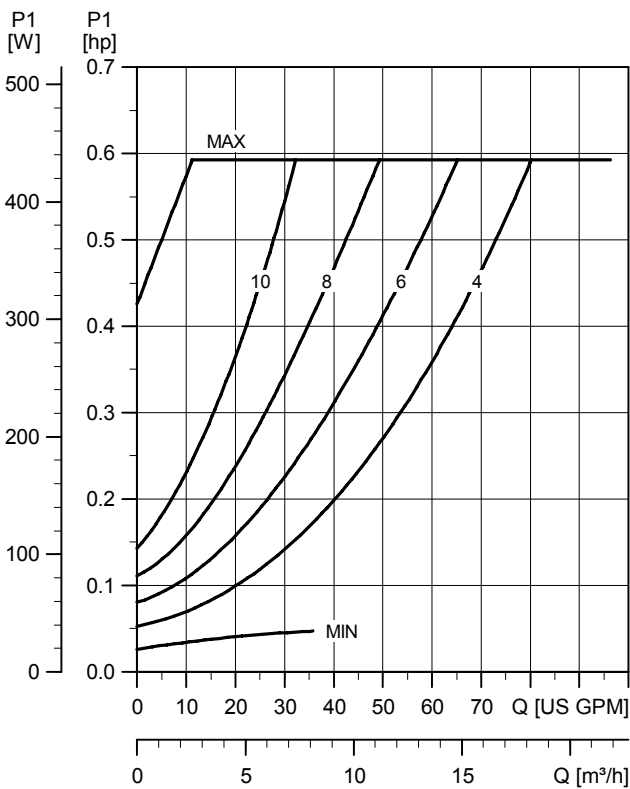
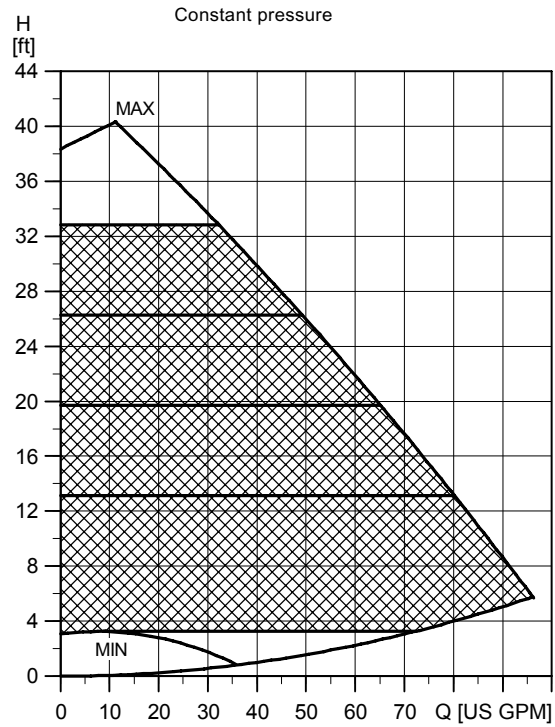
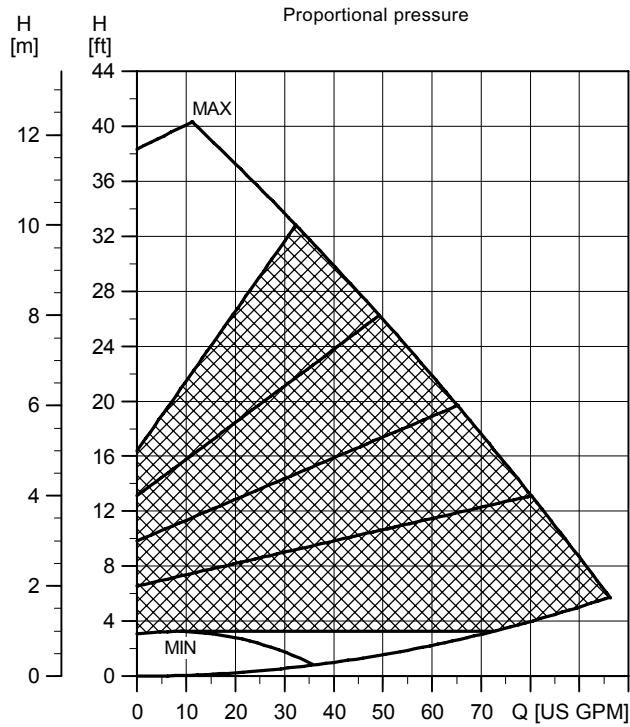

TM03 8793 2507

Performance curves/ technical data

MAGNA 40-120 F

Electrical data

U_n [V]		P_1 [W]	I_{l1} [A]
1 x 230 V	Min.	25	0.17
	Max.	450	2.0

MAGNA 40-120 F is also available with stainless-steel housing, type N.

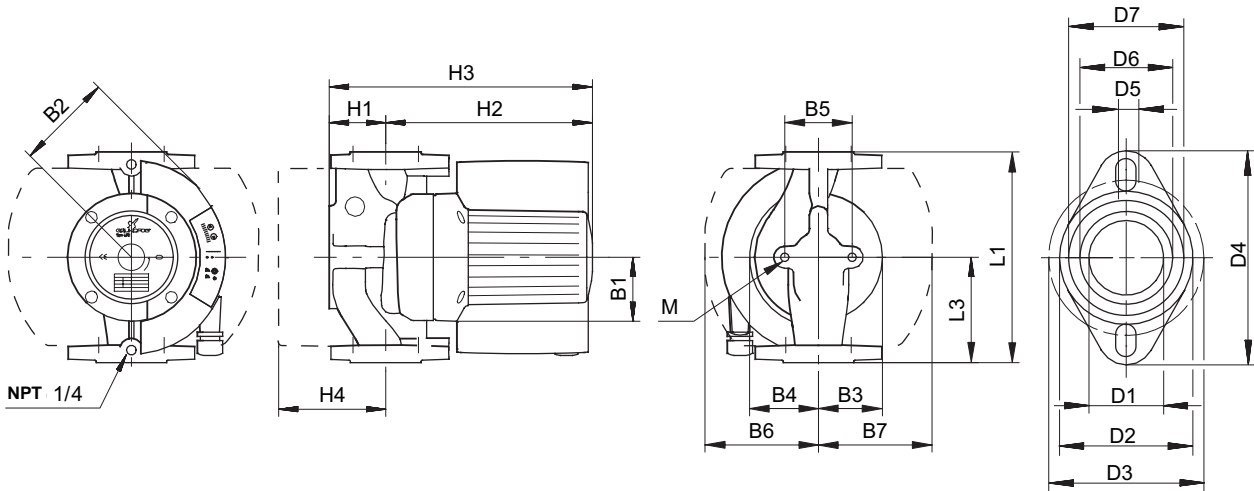

TM03 9055 3207

Dimensions and weights

Pump type	Dimensions [mm]																
	L1	L3	B1	B2	B3	B4	B5	B6	B7	H1	H2	H3	H4	D1	D2	D3	
MAGNA 40-120 F	[in]	8 1/2	4 1/4	3 1/16	4 1/2	2 15/16	3 1/8	3 3/4*	5 1/2	4 5/16	2 11/16	9 1/2	12 3/16	3 3/4	1 9/16	2 15/16	3 1/8 or 3 7/16
	[mm]	216	108	77	115	75	80	96*	140	110	68	242	310	96	40	75	80 or 87

Pump type	Dimensions [mm]					
	D4	D5	D6	D7	M	
MAGNA 40-120 F	[in]	4 3/4	1/2	1 15/16	2 3/8	M12
	[mm]	120	12	49	60	

* Stainless steel pump housing 3 1/8 [in]/80 [mm]

Weights

Pump type	Weights [lb/kg]	
	Net	Gross
MAGNA 40-120 F	34/15.5	38/17.5

MAGNA 65-120 F

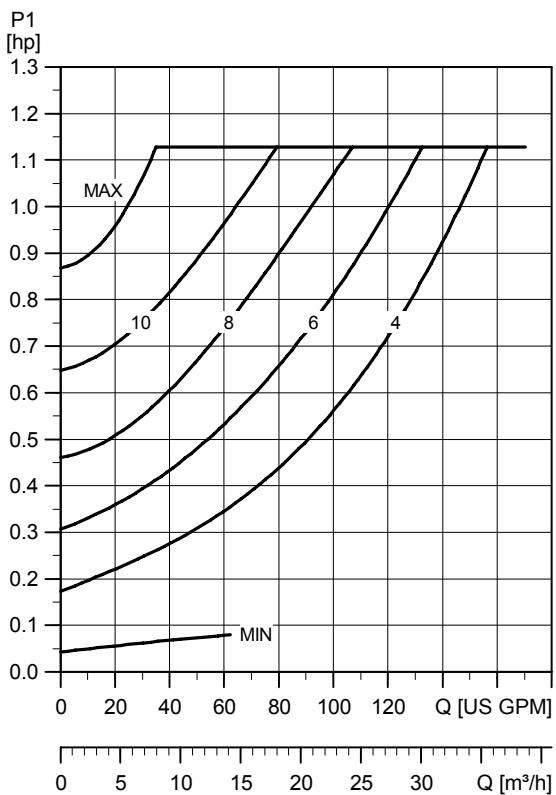
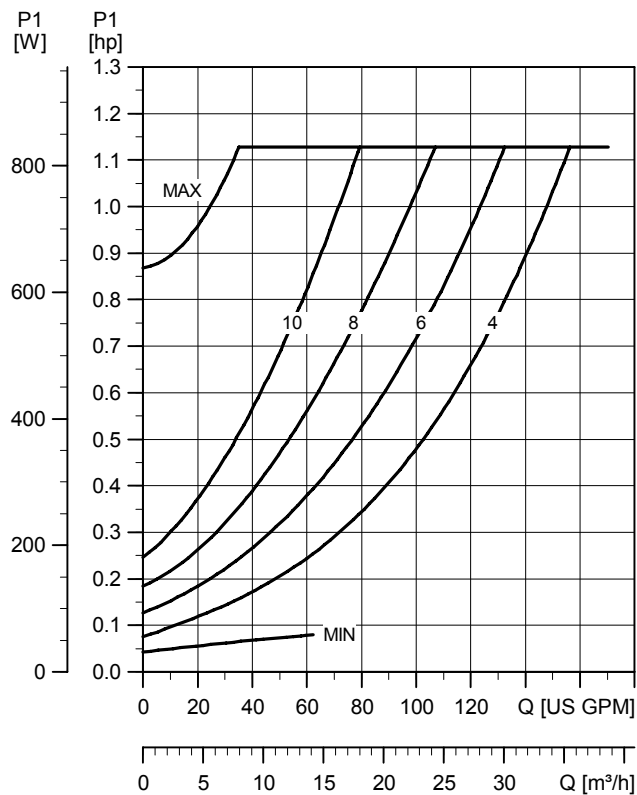
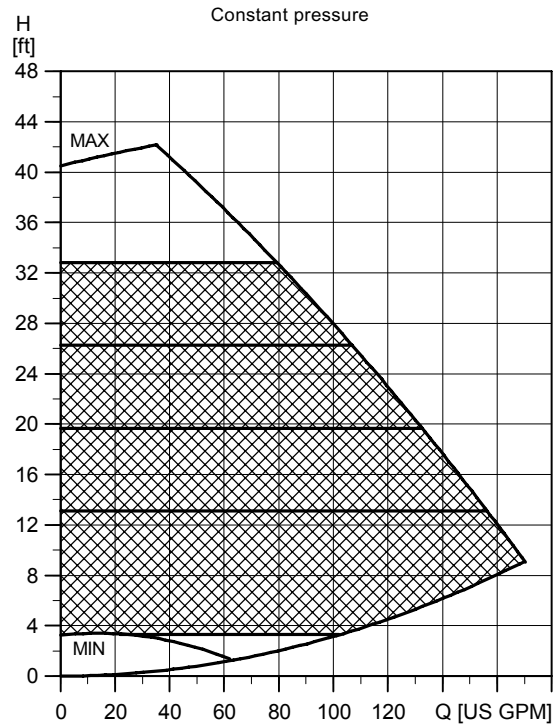
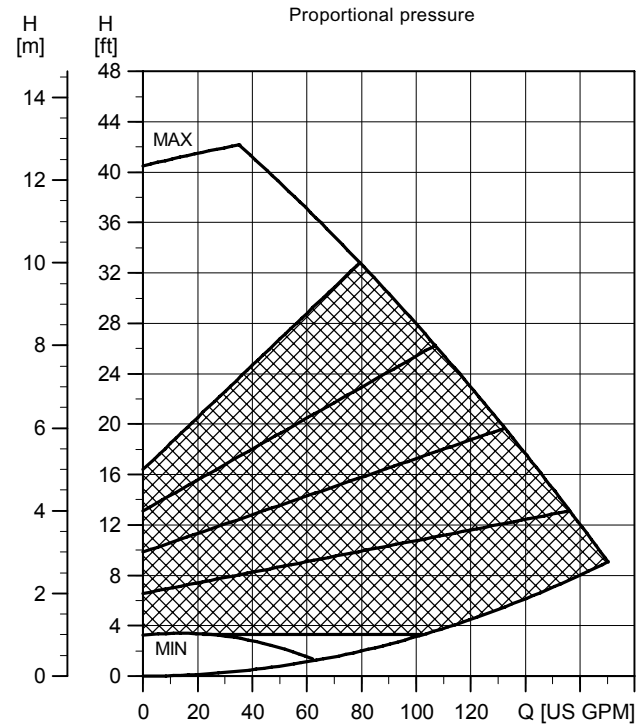

TM03 8794 2507

Performance curves/ technical data

MAGNA 65-120 F

Electrical data

U_n [V]		P_1 [W]	I_{l1} [A]
1 x 230 V	Min.	35	0.28
	Max.	900	3.9

MAGNA 65-120 F is also available with stainless-steel housing, type N.

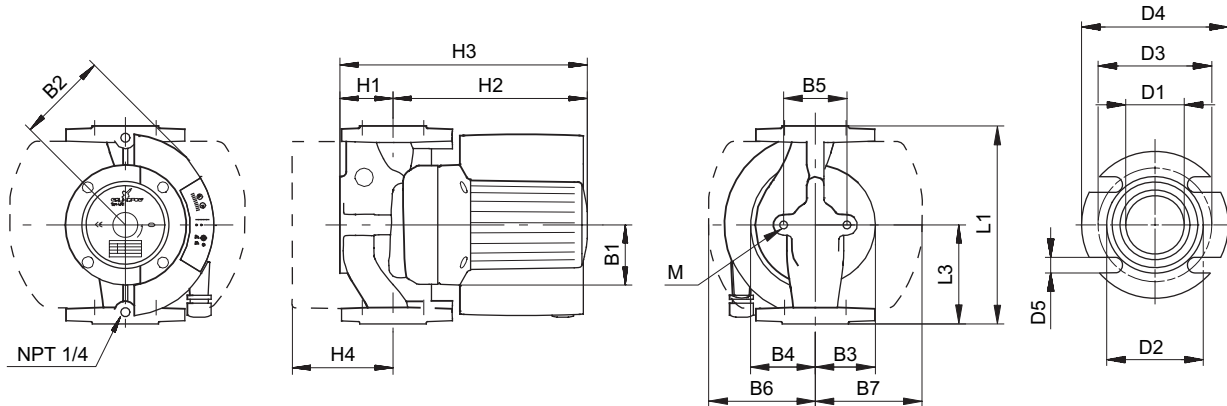

TM03 9058 3307

Dimensions and weights

Pump type	Dimensions [mm]																
	L1	L3	B1	B2	B3	B4	B5	B6	B7	H1	H2	H3	H4	D1	D2	D3	
MAGNA 65-120 F	[in]	11 1/2	5 3/4	3 1/16	4 15/16	3 7/16	4 1/8	3 3/4*	5 1/2	4 5/16	3 1/4	9 15/16	13 1/8	4 3/16	2 1/2	3 15/16	5
	[mm]	292	146	77	125	88	104	96*	140	110	82	252	334	107	63	100	127

Pump type	Dimensions [mm]			
	D4	D5	M	
MAGNA 65-120 F	[in]	6	5/8	M12
	[mm]	152	16	

* Stainless steel pump housing 3 1/8 [in]/80 [mm]

Weights

Pump type	Weights [kg]	
	Net	Gross
MAGNA 65-120 F	56/25.5	60.5/27.5

Packaged fitting sets

	Pump connection	Pipe connection	Material number	Approx. ship. wt. (lb/oz.)	
		type & size			
Flange sets ★	Cast iron	GF 15/26 flange	NPT		
			3/4	519601	2 lb 4 oz.
			1	519602	2 lb 4 oz.
			1-1/4	519603	2 lb 2 oz.
			1-1/2	519604	2 lb 2 oz.
		GF 40/43 flange	1-1/2	539605	2 lb 7 oz.
		GF 53 flange	2	91584910	12 lb
			2-1/2	91584911	12 lb
			3	91584912	12 lb
			3/4	519651	2 lb 2 oz.
	1		519652	2 lb 3 oz.	
	Bronze ★★	GF 15/26 flange	1-1/4	96409356	2 lb 1 oz.
			1-1/2	539615	3 lb
		GF 40/43 flange	2	91584913	12 lb
2-1/2			91584914	12 lb	
3			91584915	12 lb	

★ Flange sets include: 2 each - flanges, gaskets, bolts with nuts.

★★ Use bronze counter flange for stainless steel MAGNA

Insulation kits

MAGNA pumps are fitted with insulating shells. A kit consists of two shells.

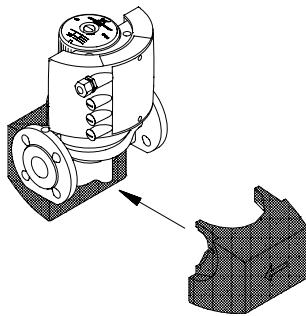

TM02 1135 0501

Fig. 23 Fitting the insulating shells to a MAGNA pump

Pump type	Product number
MAGNA 40-120 F	96746691
MAGNA 65-60 F	96746702
MAGNA 65-120 F	96746702

Expansion modules for MAGNA

MAGNA pumps can be fitted with an optional expansion module enabling communication via external signals (signal transmitters).

Two types of expansion module are available:

- GENI module
- LON module.

The expansion module is fitted by opening the terminal box cover and placing the module inside the terminal box.

Product	Product number
GENI module	605945
LON module	605809

GENI module

The GENI module has an input for an external 0-10 VDC analog signal transmitter (terminal 10 V and 1). Via this input, the pump can be controlled by an external controller if the pump has been set to one of the following control modes:

- Constant curve
- Proportional- or constant-pressure control.

The GENI module also incorporates inputs for external signals for the forced-control functions:

- Max. curve duty
- Min. curve duty.

Input signals	
Setpoint signals	<ul style="list-style-type: none"> • Max. and min. curve input External potential-free switch. Maximum contact load: 5 V, 1 mA. Screened cable.
	<ul style="list-style-type: none"> • Input for analog 0-10 V signal External signal: 0-10 VDC. Maximum load: 0.1 mA. Screened cable.
Bus input	Grundfos GENIbus protocol, RS-485. Screened cable. Lead cross section: 0.25 - 1 mm ² . Maximum cable length: 3940 ft (1200 m).

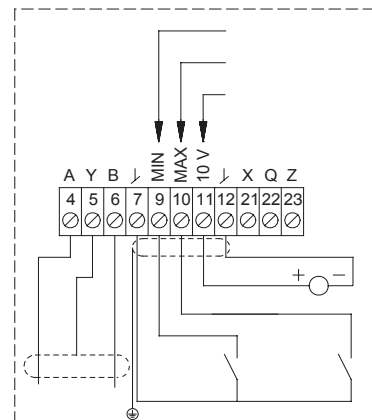
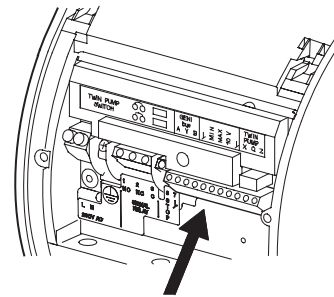

Fig. 24 Connection of GENI module

TM02 0236 1007

LON module

The LON module offers the possibility of connecting the pump to a LonWorks® network. The module is used for data transmission between a network and the MAGNA pump.

Input signals	
Bus input	LonTalk® protocol, FTT 10. Non-screened, twisted-pair cable. Lead cross section: 0.25 - 1 mm ² .

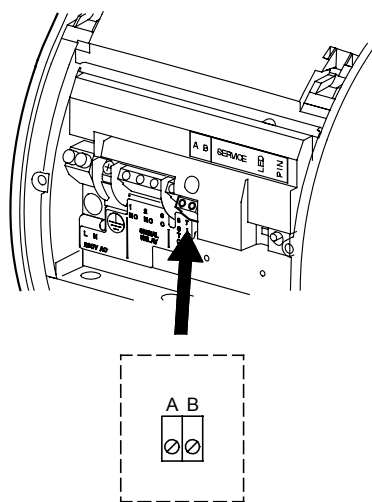

TM02.0237.0904

Fig. 25 Connection of LON module

R100

The R100 is designed for wireless communication with the pump. The 100 communicates with the pump via infra-red light.

Product	Product number
R100	96615297

MAGNA, cast iron

Pump type	Pipe connection		Product number	
			Flange connection	
	1.5"	2.5"	GF 15/40	GF 53
MAGNA 65-60 F		X	–	96734634
MAGNA 40-120 F	X		96734489	–
MAGNA 65-120 F		X	–	96734640

MAGNA, stainless steel

Pump type	Pipe connection		Product number	
			Flange connection	
	1.5"	2.5"	GF 15/40	GF 53
MAGNA 65-60 FN		X	–	96734637
MAGNA 40-120 FN	X		96734633	–
MAGNA 65-120 FN		X	–	96734642

WebCAPS

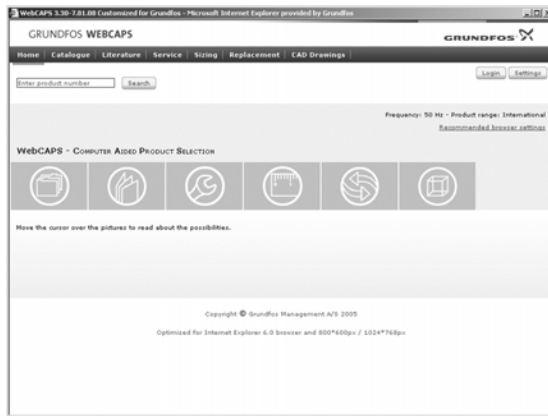

WebCAPS is a **Web-based Computer Aided Product Selection** program available on www.grundfos.com.

WebCAPS contains detailed information on more than 185,000 Grundfos products in more than 22 languages.

In WebCAPS, all information is divided into 6 sections:

- Catalogue
- Literature
- Service
- Sizing
- Replacement
- CAD drawings.

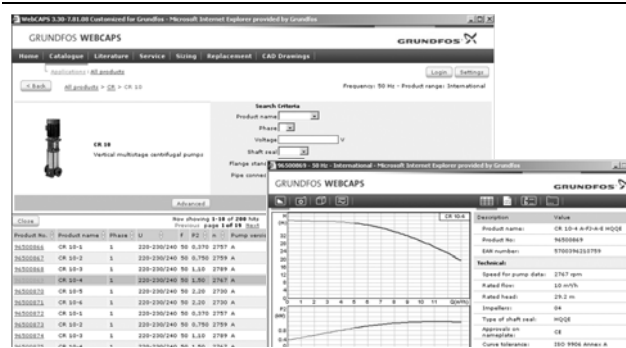

Catalogue

This section is based on fields of application and pump types, and contains

- technical data
- curves (QH, Eta, P1, P2, etc) which can be adapted to the density and viscosity of the pumped liquid and show the number of pumps in operation
- product photos
- dimensional drawings
- wiring diagrams
- quotation texts, etc.

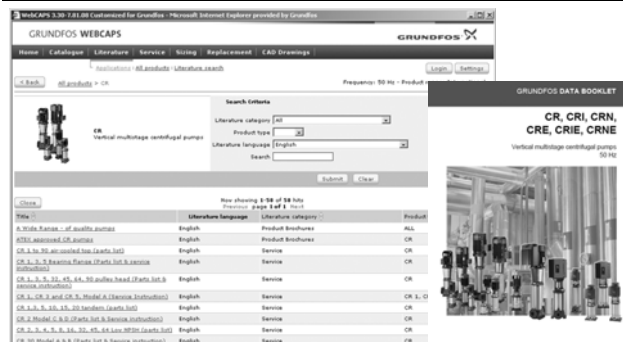

Literature

In this section you can access all the latest documents of a given pump, such as

- data booklets
- installation and operating instructions
- service documentation, such as Service kit catalogue and Service kit instructions
- quick guides
- product brochures, etc.



Service

This section contains an easy-to-use interactive service catalogue. Here you can find and identify service parts of both existing and discontinued Grundfos pumps.

Furthermore, this section contains service videos showing you how to replace service parts.



Sizing

This section is based on different fields of application and installation examples, and gives easy step-by-step instructions in how to

- select the most suitable and efficient pump for your installation
- carry out advanced calculations based on energy consumption, payback periods, load profiles, life cycle costs, etc.
- analyse your selected pump via the built-in life cycle cost tool
- determine the flow velocity in wastewater applications, etc.



Replacement

In this section you find a guide to selecting and comparing replacement data of an installed pump in order to replace the pump with a more efficient Grundfos pump. The section contains replacement data of a wide range of pumps produced by other manufacturers than Grundfos.

Based on an easy step-by-step guide, you can compare Grundfos pumps with the one you have installed on your site. When you have specified the installed pump, the guide will suggest a number of Grundfos pumps which can improve both comfort and efficiency.

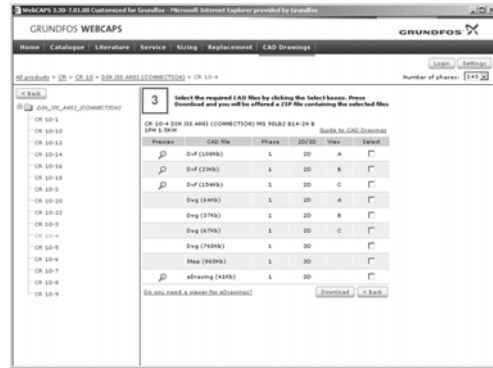

CAD drawings

In this section it is possible to download 2-dimensional (2D) and 3-dimensional (3D) CAD drawings of most Grundfos pumps.

These formats are available in WebCAPS:

2-dimensional drawings:

- .dxf, wireframe drawings
- .dwg, wireframe drawings.

3-dimensional drawings:

- .dwg, wireframe drawings (without surfaces)
- .stp, solid drawings (with surfaces)
- .eprt, E-drawings.

WinCAPS



Fig. 26 WinCAPS CD-ROM

WinCAPS is a **Windows-based Computer Aided Product Selection** program containing detailed information on more than 185,000 Grundfos products in more than 22 languages.

The program contains the same features and functions as WebCAPS, but is an ideal solution if no Internet connection is available.

WinCAPS is available on CD-ROM and updated once a year.

L-MAG-PG-01 09/07	US

Subject to alterations.

GRUNDFOS Pumps Corporation
17100 West 118th Terrace
Olathe, Kansas 66061
Phone: +1-913-227-3400
Telefax: +1-913-227-3500

GRUNDFOS Canada Inc.
2941 Brighton Road
Oakville, Ontario L6H 6C9 Canada
Phone: +1-905 829 9533
Telefax: +1-905 829 9512

Bombas GRUNDFOS de Mexico S.A. de C.V.
Boulevard TLC No. 15
Parque Industrial Stiva Aeropuerto
Apodaca, N.L. Mexico 66600
Phone: +52-81-8144 4000
Telefax: +52-81-8144 4010