

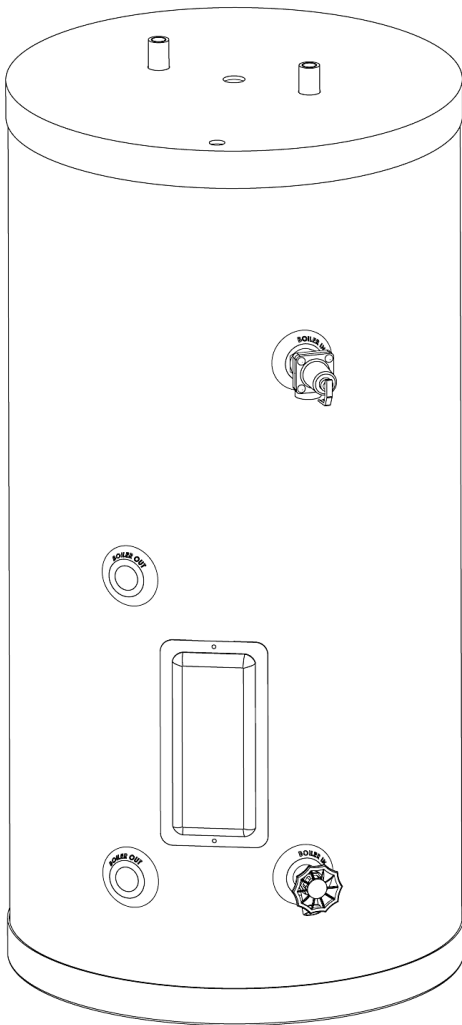

# *SuperStor Contender Indirect Fired Water Heater*



**INSTALLATION**

**START-UP**

**MAINTENANCE**

**PARTS**

***SuperStor Contender  
Water Heater Models***

**SSC-35 / SSC-50 / SSC-80 / SSC-119\***

***\*NOTE: A suffix of "S" denotes Solar Model***

***NOTICE: HTP reserves the right to make product changes or updates without notice and will not be held liable for typographical errors in literature.***

**NOTE TO CONSUMER: PLEASE KEEP ALL INSTRUCTIONS FOR FUTURE REFERENCE.**

## SPECIAL ATTENTION BOXES

The following defined terms are used throughout this manual to bring attention to the presence of hazards of various risk levels, or to important product information.

### **DANGER**

**DANGER** indicates an imminently hazardous situation which, if not avoided, will result in death or serious injury.

### **WARNING**

**WARNING** indicates a potentially hazardous situation which, if not avoided, could result in death or serious injury.

### **CAUTION**

**CAUTION** indicates a potentially hazardous situation which, if not avoided, may result in minor or moderate injury.

### **CAUTION**

**CAUTION** used without the safety alert symbol indicates a potentially hazardous situation which, if not avoided, may result in property damage.

## FOREWORD

This manual is intended to be used in conjunction with other literature provided with the SuperStor Contender Indirect Fired Water Heater. This includes all related control information. It is important that this manual, all other documents included with this system, and additional publications, be reviewed in their entirety before beginning any work.

Installation should be made in accordance with the regulations of the local code authorities and utility companies which pertain to this type of water heating equipment.

## FOR THE INSTALLER

### **WARNING**

This manual must only be used by a qualified heating installer/service technician. Read all instructions in this manual before installing. Perform steps in the order given. Failure to comply could result in substantial property damage, severe personal injury, or death.

This water heater must be installed by qualified and licensed personnel. The installer should be guided by the instructions furnished with the water heater, and with local codes and utility company requirements.

#### INSTALLATIONS MUST COMPLY WITH:

Local, state, provincial, and national codes, laws, regulations and ordinances.

The latest version of the *National Electrical Code*, *NFPA No. 70*.

*Code for the Installation of Heat Producing Appliances* (latest version), from American Insurance Association, 85 John Street, New York, NY 11038.

# TABLE OF CONTENTS

<b>PART 1 – GENERAL SAFETY INFORMATION .....</b>	<b>4</b>
A. PRECAUTIONS .....	4
B. WHEN SERVICING THE WATER HEATING SYSTEM.....	4
C. HEATER WATER .....	4
<b>PART 2 – PREPARE THE WATER HEATER .....</b>	<b>4</b>
A. SPECIFICATIONS AND PERFORMANCE RATINGS .....	5
B. PERFORMANCE AND SIZING GUIDELINES .....	6
C. LOCATING THE WATER HEATER.....	6
D. ANODE ROD .....	7
<b>PART 3 – HEATER PIPING .....</b>	<b>7</b>
A. PLUMBING .....	7
B. BOILER CONNECTIONS .....	7
C. COLD WATER INLET.....	8
D. SCALDING .....	8
E. TEMPERATURE AND PRESSURE RELIEF VALVE.....	9
F. HOT WATER OUTLET .....	9
G. POTABLE EXPANSION TANK.....	10
H. PRESSURE DROP SIZING FOR CIRCULATOR .....	10
I. INSTALLATION DIAGRAMS.....	11
<b>PART 4 – HEATER CONTROL AND WIRING .....</b>	<b>16</b>
A. CONTROL .....	16
B. WIRING .....	16
<b>PART 5 – OPERATING THE HEATER .....</b>	<b>16</b>
<b>PART 6 – MAINTENANCE AND TROUBLESHOOTING.....</b>	<b>17</b>
HTP CUSTOMER INSTALLATION RECORD FORM.....	20

## PART 1 – GENERAL SAFETY INFORMATION

### A. PRECAUTIONS

This water heater is approved for indoor installations only. Clearance to combustible materials: 0” top, bottom, sides and back. Heater must have room for service: 24” front and 6” sides are minimum recommended service clearances. (A combustible door or removable panel is acceptable front clearance.) This water heater has been approved for closet installation, and installation on combustible flooring. Do not install this water heater directly on carpeting.

#### **WARNING**

**INSTALLER** – Read all instructions in this manual before installing. Perform steps in the order given.

**USER** – This manual is for use only by a qualified heating installer/service technician. Have this heater serviced/inspected by a qualified service technician annually.

**FAILURE TO ADHERE TO THE GUIDELINES ON THIS PAGE CAN RESULT IN SUBSTANTIAL PROPERTY DAMAGE, SEVERE PERSONAL INJURY, OR DEATH.**

#### **WARNING**

**NOTE:** If the heater is exposed to the following, do not operate until all corrective steps have been made by a qualified serviceman:

1. FIRE
2. DAMAGE
3. WATER

Any claims for damage or shortage in shipment must be filed immediately against the transportation company by the consignee.

DO NOT USE THIS WATER HEATER IF ANY PART HAS BEEN UNDERWATER. Immediately call a qualified service technician. Replace any part of the control unit that has been under water.

### B. WHEN SERVICING THE WATER HEATING SYSTEM

- To avoid electric shock, disconnect electrical supply before performing maintenance.
- To avoid severe burns, allow heater to cool before servicing.

### C. HEATER WATER

- Do not use petroleum-based cleaning or sealing compounds in a water heating system. Gaskets and seals in the system may be damaged. This can result in substantial property damage.
- Do not use “homemade cures” or “heater patent medicines”. Damage to heater, substantial property damage, and/or serious personal injury may result.

## PART 2 – PREPARE THE WATER HEATER

#### **CAUTION**

**UNCRATING HEATER** – Any claims for damage or shortage in shipment must be filed immediately against the transportation company by the consignee.

#### **CAUTION**

**COLD WEATHER HANDLING** – If the heater has been stored in a very cold location (BELOW 0°F) before installation, handle with care until the plastic components come to room temperature.

Remove all sides of the shipping crate to allow the heater to be moved into its installation location.

### **A. SPECIFICATIONS AND PERFORMANCE RATINGS**

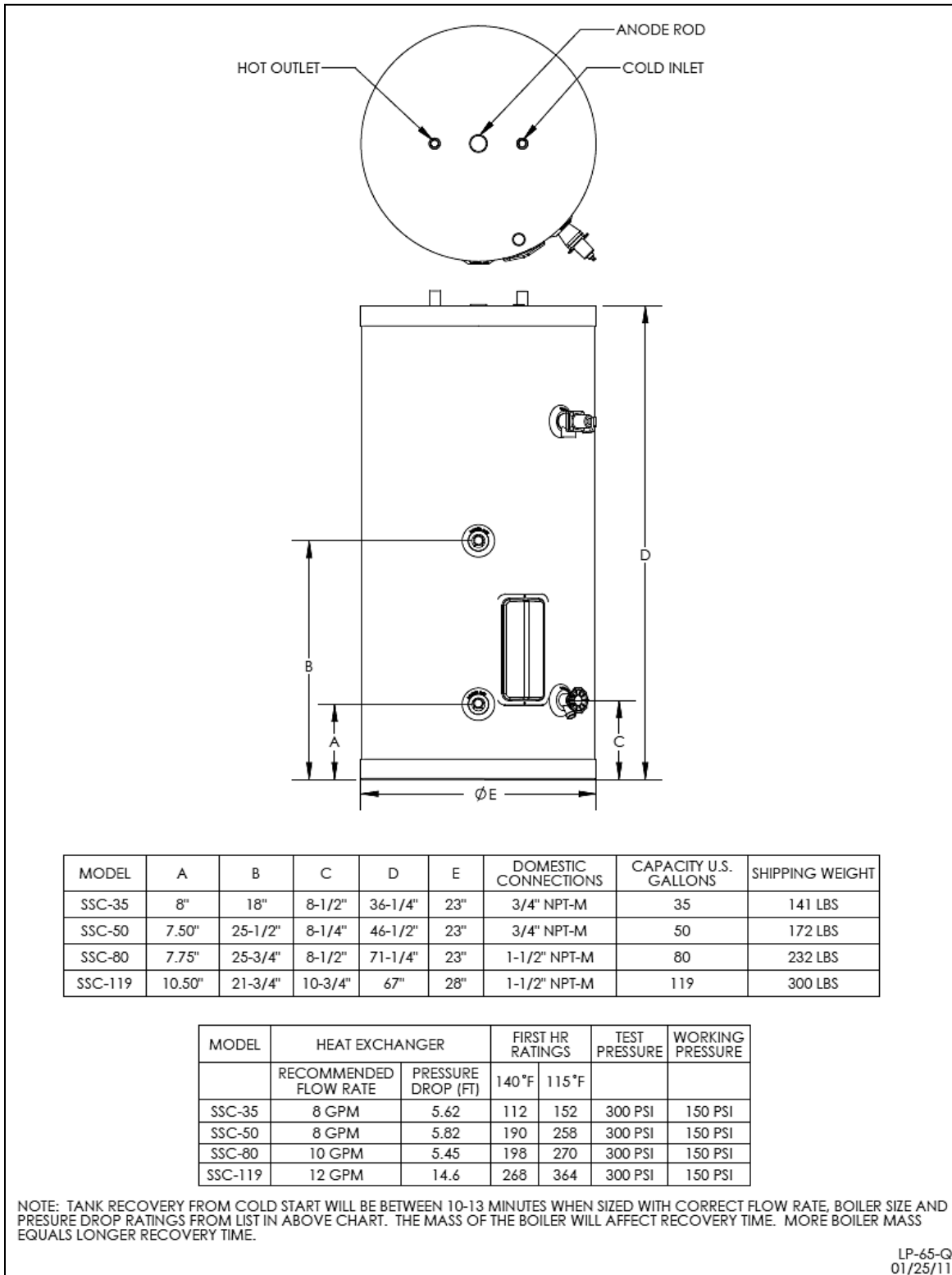

**Figure 1 – Specifications and Dimensions**

**B. PERFORMANCE AND SIZING GUIDELINES**

Determine the amount of domestic hot water needed, then use the chart below to optimize water heater against boiler sizing.

MODEL	GROSS BOILER OUTPUT	140°F 90°F ΔT	127°F 77°F ΔT	115°F 65°F ΔT
SSC-35	53,000	112	125	152
SSC-50	86,000	190	213	258
SSC-80	91,000	198	221	270
SSC-119	108,000	268	300	364

Table 1

**NOTE:** Above chart is based on boiler size conforming to the minimum BTU/H required to achieve first hour ratings. The mass of the boiler will affect recovery time. More boiler mass equals longer recovery time.

**C. LOCATING THE WATER HEATER**

This water heater is certified for indoor use only. DO NOT INSTALL OUTDOORS. Outdoor installations ARE NOT covered by warranty.

Choose a location for the water heater as centralized to the piping system as possible. Also, locate the water heater and domestic water piping where it will not be exposed to freezing temperatures. All piping should be insulated. Additionally, place the water heater so that the drain, controls, and inlets/outlets are easily accessible.

This water heater must be installed vertical on a level surface.

**CAUTION**

Locate the water heater where any leakage from the relief valve, related piping, tank, or connections will not result in damage to surrounding areas or lower floors of the building. The water heater should be located near a floor drain, or installed in a drain pan. HTP WILL NOT be held liable for leakage damages.

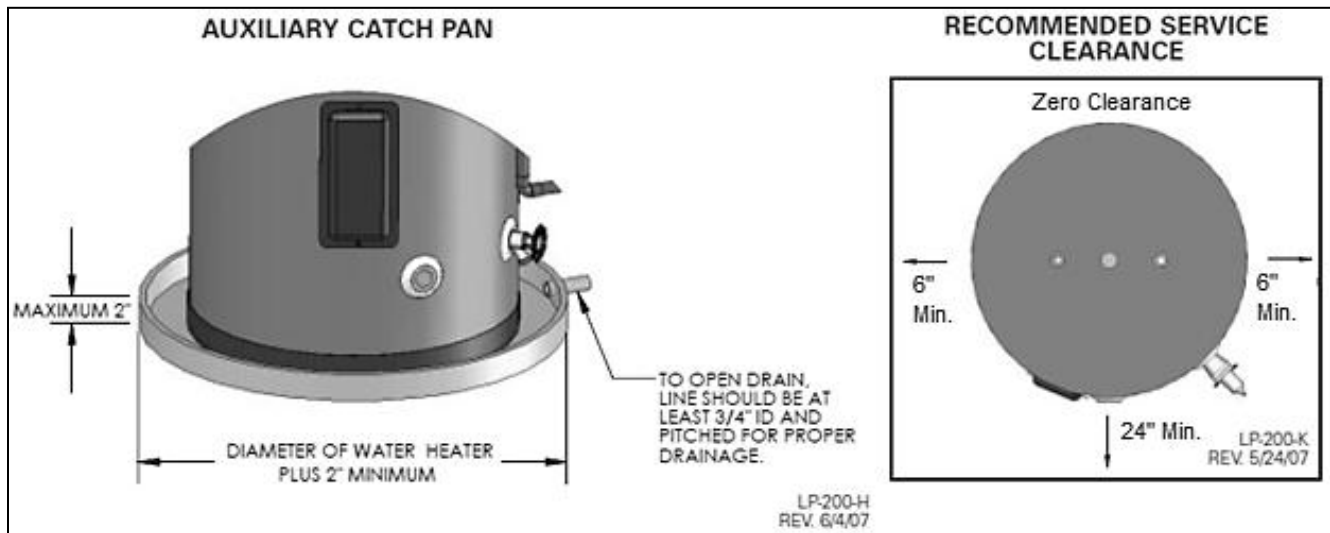

Figure 2

If you do not provide the minimum clearances shown, it might not be possible to service the heater without removing it from the space.

## **DANGER**

This water heater must not be located near flammable liquids such as gasoline, butane, liquefied propane, adhesives, solvents, paint thinners, etc., as the controls of this water heater could ignite these vapors and cause an explosion, resulting in property damage, severe personal injury, or death.

### **D. ANODE ROD**

This water heater is equipped with a magnesium anode rod. Anode rods are sacrificial components that counteract water chemistry to minimize or eliminate tank corrosion.

The anode rod should be inspected annually and replaced as necessary to prolong tank life. Have the supply water quality professionally analyzed, as local water conditions will influence the duration for inspection and replacement of anode rod.

The use of a water softener may increase the speed of anode consumption. More frequent inspection of the anode is needed when using softened or treated water.

Water with high sulfate and/or mineral content can produce a rotten egg odor in heated water. Chlorinating the water supply may minimize this problem.

**NOTE:** Failure of a heat exchanger due to lime scale build-up on the heating surface, low pH or other imbalance IS NOT covered by the warranty.

**NOTE:** Do not remove the anode rod from an operating water heater. Operating the water heater without the anode rod will shorten the life of the tank and VOID the warranty.

## **PART 3 – HEATER PIPING**

### **A. PLUMBING**

It is mandatory that all plumbing be done in accordance with federal, local, and state plumbing codes and practices. Failure to properly install the water heater WILL VOID the warranty. It is also necessary to use both thread tape and pipe dope on all mechanical plumbing connections.

### **CAUTION**

When filling the water heater, open a hot water tap to release air in the tank and piping. Failure to do so could lead to improper water heater operation.

### **B. BOILER CONNECTIONS**

### **CAUTION**

Use two wrenches when tightening water piping at heater. Use one wrench to prevent the heater return or supply line from turning. Failure to prevent piping connections from turning could cause damage to heater components.

Use a 1" nominal minimum pipe size when piping with zone valves or circulators.

On the water heater, the boiler supply connects to the outlet of the circulator. The circulator inlet is to be connected to the "HOT OUTLET" side of the boiler. Be sure that the arrow on the circulator is facing the correct flow direction. (See pressure drop sizing for circulator, this manual.) On the tank, the boiler return is to be connected to the return side of the boiler. The return(s) from heating loop(s) should have a flow check or swing check valve installed before the return pipe from the tank.

In a steam boiler, the tank supply must be connected to the boiler well below the minimum water level. A strainer and drain valve should be installed at the boiler for periodic draining of scale and sludge. Banging and steam bound traps will occur if the boiler water supplied to the heat exchanger has steam or is slightly above the low water cut off.

### CAUTION

The water heater heat exchanger cannot be used with non-barrier radiant pipe systems. Use with closed loop boiler systems only.

### C. COLD WATER INLET

Use both thread tape and pipe dope to connect an NPT female x 3/4" minimum pipe adapter.

### CAUTION

Dielectric fittings must be used on water heater connections.

A shut off valve between the city water supply and tank inlet is recommended for ease of service.

### CAUTION

Exercise caution when soldering water heater connections, as outlet and inlet dip tubes are plastic.

It may be recommended to use a back flow preventer – check local codes. If a back flow preventer or a no return valve is used, a thermal expansion tank must be installed on the cold water supply between the tank and valve. If the tank is replacing a tankless coil in the boiler, disconnect coil plumbing and use the cold inlet pipe and hot water outlet pipes for the water heater.

**NOTE:** DO NOT PLUG OUTLET IN TANKLESS COIL.

### D. SCALDING

## ⚠ DANGER



**⚠ DANGER**

**Water temperature over 125 degrees F. can cause severe burns instantly, or death from scalds. Children, disabled, and elderly are at highest risk of being scalded. See instruction manual before setting temperature at water heater. Feel water before bathing or showering! Temperature limiting valves are available. See chart below showing temperature burn rate.**



**⚠ DANGER**

This heater can deliver scalding water. Be careful whenever using hot water to avoid scalding injury. Certain appliances, such as dishwashers and automatic clothes washers may require increased water temperature. By setting the thermostat on this heater to obtain the increased water temperature required by these appliances, you may create the potential for scald injury.

To protect against injury, you should install a mixing valve in the water system. This valve will reduce point of discharge temperature by mixing cold and hot water in branch supply lines. Such valves are available from your local plumbing supplier.

APPROXIMATE TIME / TEMPERATURE RELATIONSHIPS IN SCALDS	
120°F	More than 5 minutes
125°F	1 ½ to 2 minutes
130°F	About 30 seconds
135°F	About 10 seconds
140°F	Less than 5 seconds
145°F	Less than 3 seconds
150°F	About 1 ½ seconds
155°F	About 1 second

**Table 2**



Table 2 details the relationship of water temperature and time with regard to scald injury and may be used as a guide in determining the safest water temperature for your applications.

### **E. TEMPERATURE AND PRESSURE RELIEF VALVE**

A factory installed temperature and pressure relief valve long element, meeting the requirements for relief valves for hot water heaters ANSI Z21.22B / CSA 4.4-M99, has been installed for your safety and convenience. If servicing, make sure that the relief valve is sized to the BTU/hour capacity and storage capacity of the water heater. If the relief valve weeps, see expansion tank section for suggestions.

#### **⚠ WARNING**

Do not thread a cap or plug into the relief valve under any circumstances! Explosion and property damage, serious injury, or death may result.

#### **⚠ WARNING**

To avoid water damage or scalding due to relief valve operation:

- Discharge line must be connected to relief valve outlet and run to a safe place of disposal. Terminate the discharge line in a manner that will prevent possibility of severe burns or property damage should the relief valve discharge.
- Discharge line must be as short as possible and the same size as the valve discharge connection throughout its entire length.
- Discharge line must pitch downward from the valve and terminate at least 6" above the floor drain, making discharge clearly visible.
- The discharge line shall terminate plain, not threaded, with a material serviceable for temperatures of 375°F or greater.
- Do not pipe discharge to any location where freezing could occur.
- No shutoff valve may be installed between the relief valve and heater or in the discharge line. Do not plug or place any obstruction in the discharge line.
- Test the operation of the relief valve after filling and pressurizing the system by lifting the lever. Make sure the valve discharges freely. If the valve fails to operate correctly, immediately replace with a new properly rated relief valve.
- Test T&P valve at least once annually to ensure the waterway is clear. If valve does not operate, turn the heater "off" **and call a plumber immediately.**
- Take care whenever operating relief valve to avoid scalding injury or property damage.

**FAILURE TO COMPLY WITH THE ABOVE GUIDELINES COULD RESULT IN FAILURE OF RELIEF VALVE OPERATION, RESULTING IN POSSIBILITY OF SUBSTANTIAL PROPERTY DAMAGE, SEVERE PERSONAL INJURY, OR DEATH.**

### **F. HOT WATER OUTLET**

Use both thread tape and pipe dope to connect an NPT male x 3/4" (minimum) pipe adapter. A shut off valve between the hot water supply and tank outlet is recommended for ease of service at a later date. Use a backflow preventer specifically designed for water heater installations. This valve should be installed on the cold water fill supply line per local codes.

#### **CAUTION**

Dielectric fittings must be used on water heater connections.

## CAUTION

Due to the plastic dip tube in the cold water inlet, exercise extreme caution when soldering.

## ⚠ WARNING

A temperature limiting or mixing valve is not entirely necessary, but recommended in installations servicing disabled or elderly persons, or children. Take extreme caution to avoid scalding when temperature limiting or mixing valves are not used.

### **G. POTABLE EXPANSION TANK**

A potable hot water expansion tank is required to offset heated water expansion. If there is a back flow preventer or any other type of no return or check valve on the system, a thermal expansion tank is mandatory. The expansion tank must be sized for the entire water volume of the hot water system. A weeping relief valve indicates the need for an expansion tank. See Typical Expansion Tank installation, Fig. 3, for more details.

### **H. PRESSURE DROP SIZING FOR CIRCULATOR**

Use the chart below to properly calculate circulator flow rate for the installation. The flow chart below represents the pipe run, water heater, and heat exchanger ONLY and does not include any flow checks, zone valves, or friction loss through the boiler.

PRESSURE DROP FOR PIPE LENGTH OF 1" COPPER, AND FOR SIX 90° ELBOWS, AND ON TEE ON THE RUN						
	PIPE SIZE	20'	30'	40'	50'	60'
<b>SSC-35</b>	8 GPM	6.28	6.53	6.78	6.28	7.28
<b>SSC-50</b>	8 GPM	6.48	6.73	6.98	7.23	7.48
<b>SSC-80</b>	10 GPM	6.19	6.55	6.85	7.15	7.45
<b>SSC-119</b>	12 GPM	16.19	16.79	17.39	17.99	18.59

Table 3

**I. INSTALLATION DIAGRAMS**

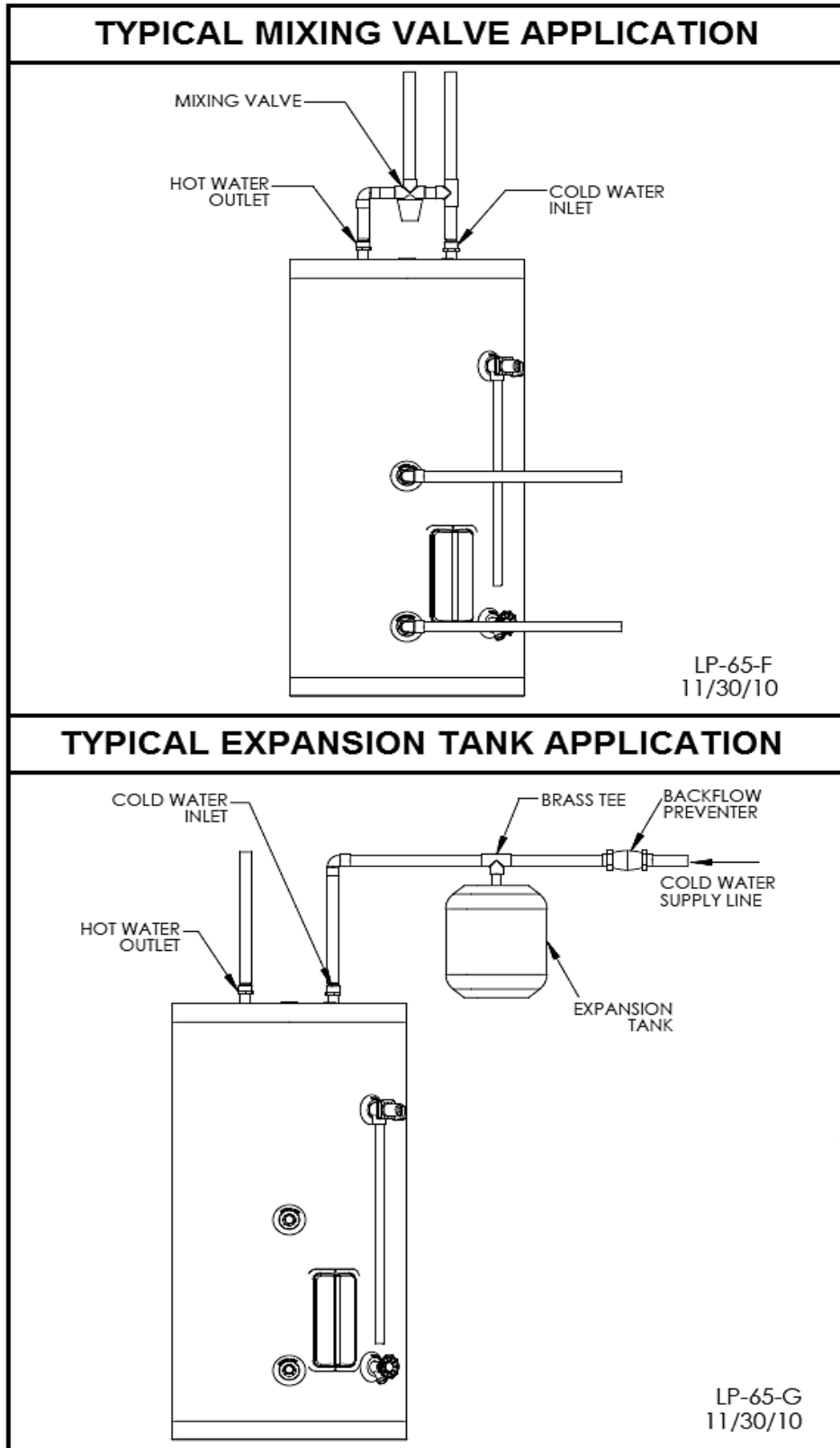

Figure 3

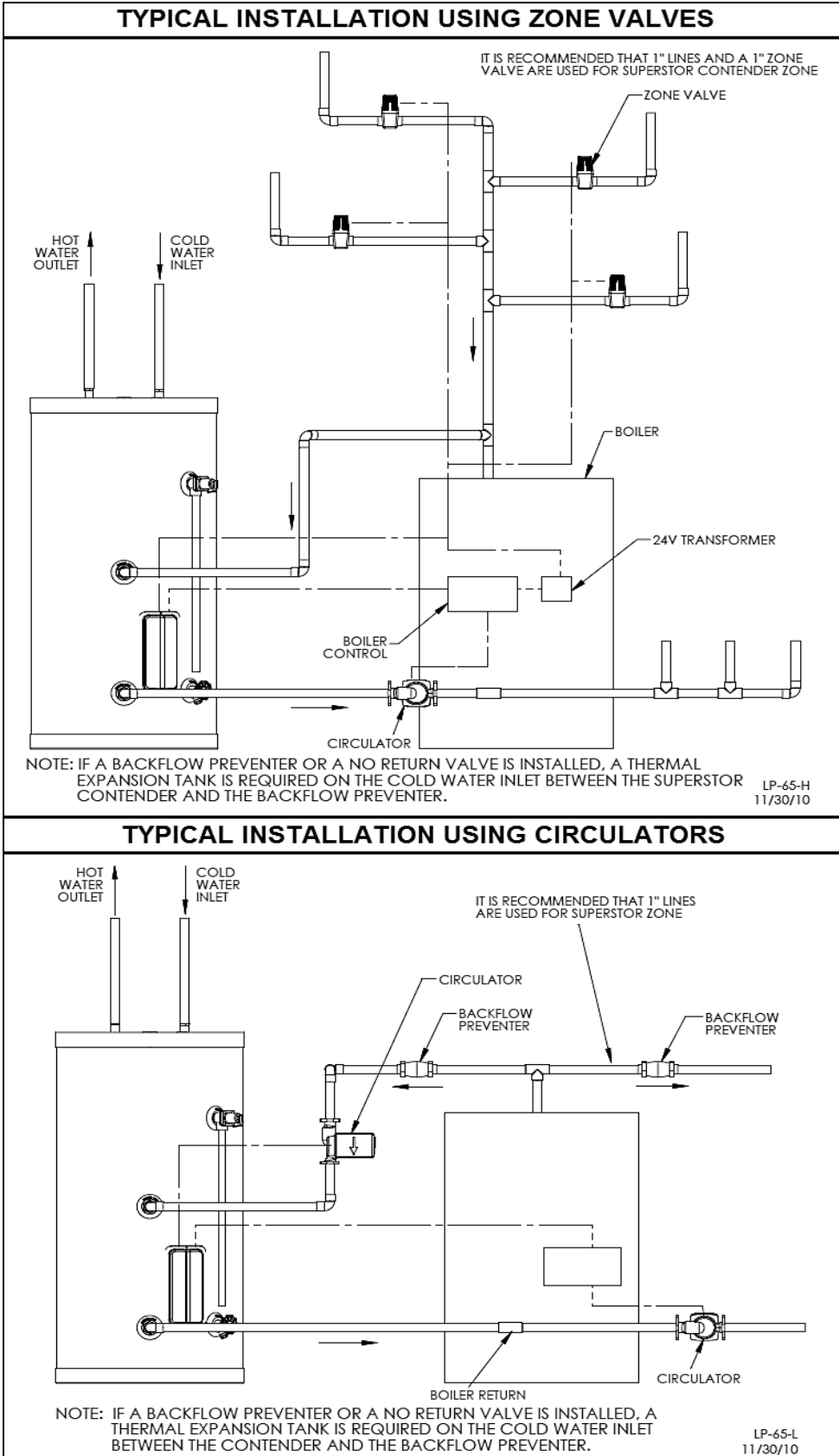
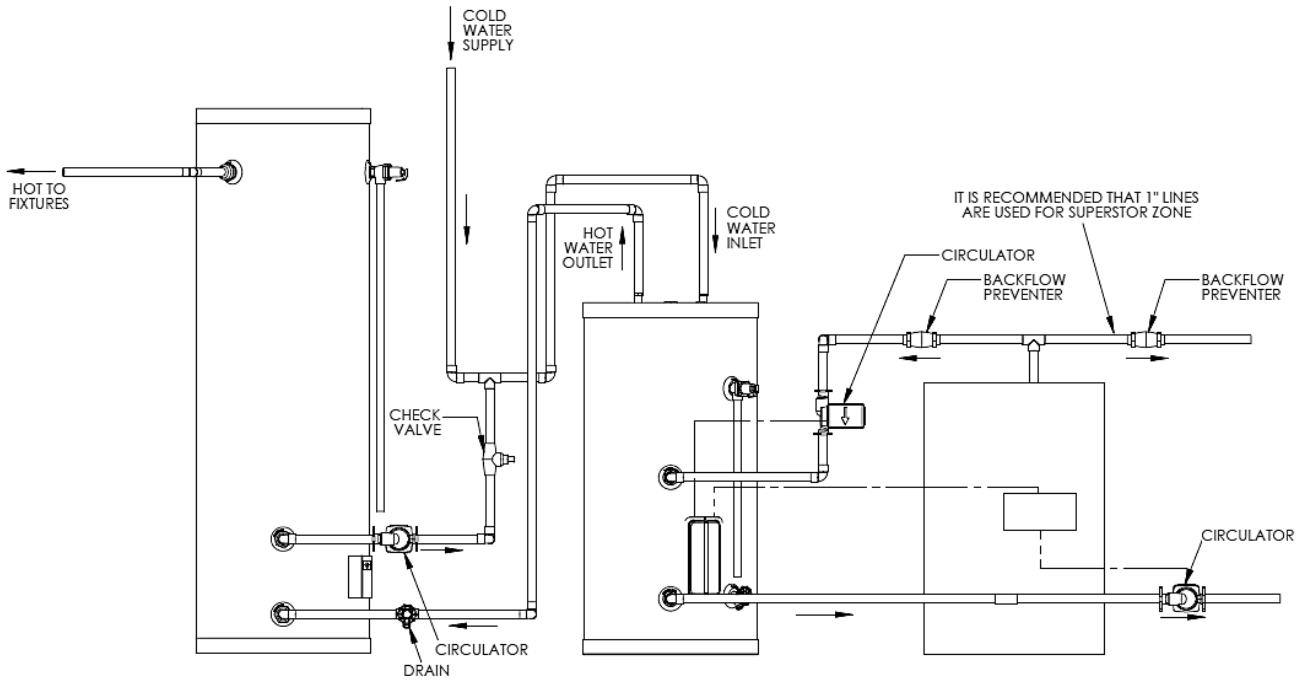

Figure 4

### TYPICAL SSC SERIES WATER HEATER WITH STORAGE TANK INSTALLATION



NOTE: IF A BACKFLOW PREVENTER OR A NO RETURN VALVE IS INSTALLED, A THERMAL EXPANSION TANK IS REQUIRED ON THE COLD WATER INLET BETWEEN THE SUPERSTOR AND THE BACKFLOW PREVENTER.

LP-65-M  
11/30/10

### MULTIPLE TANK INSTALLATIONS

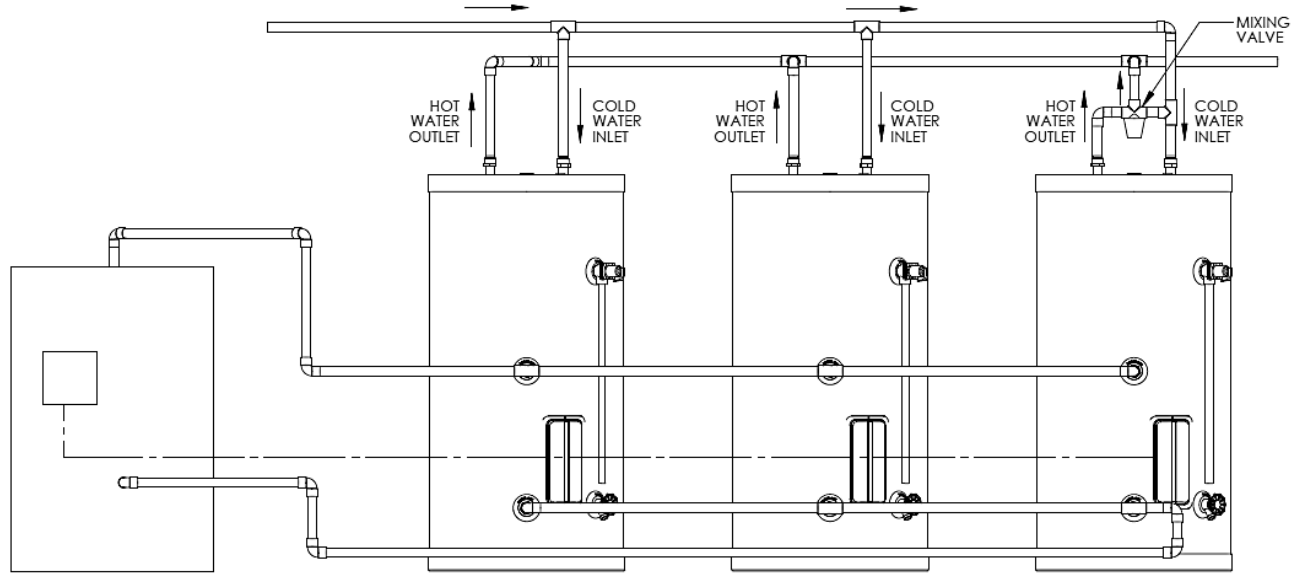

NOTE: ALL PIPING IN PARALLEL IS USED FOR LARGE DUMPS OF HOT WATER, HIGH USAGE, SHORT DURATION

LP-65-N  
11/30/10

Figure 5





## PART 4 – HEATER CONTROL AND WIRING

### A. CONTROL

A surface mounted control is provided and mounted inside of the control access compartment. There is an insulation blanket under the control access cover to ensure accurate readings of water temperature. The control is factory set at 120°F for your safety (see scald danger warning above). The differential is fixed at 3° to 5° (not adjustable).

### B. WIRING

Wiring is to be done in accordance with all applicable local and state codes. Turn off all power related to the boiler starting and wiring procedures. It is recommended that a disconnect switch be installed between the boiler control and water heater.

## PART 5 – OPERATING THE HEATER

Boiler high limit should be at least 20°F higher than the heater temperature. Set the low limit of the boiler control at the minimum setting – this will call the burner on to satisfy the tank control.

We recommend a water heater temperature setting of 120°F. However, a lower temperature setting may be required to comply with local and state codes for normal operation. The differential is fixed at 3° to 5°. You may prefer a setting of either higher or lower water temperature. A mixing valve in conjunction with a high temperature setting may be used for high demand applications (spas, hot tubs, whirlpools).

### **CAUTION**

If draining of the heater is necessary, open the temperature and pressure valve or a hot water tap to prevent vacuum buildup in the tank and piping.

### **⚠ WARNING**

Risk of scald injury increases as you increase water temperature.



## PART 6 – MAINTENANCE AND TROUBLESHOOTING

Periodic maintenance should be performed by a qualified service technician to assure that all the equipment is operating safely and efficiently. The owner should make necessary arrangements with a qualified heating contractor for periodic maintenance of the heater. Installer must also inform the owner that the lack of proper care and maintenance of the heater may result in a hazardous condition.

INSPECTION ACTIVITIES		DATE LAST COMPLETED			
PIPING		1 <sup>st</sup> YEAR	2 <sup>nd</sup> YEAR	3 <sup>rd</sup> YEAR	4 <sup>th</sup> YEAR*
Near heater piping	Check heater and system piping for any sign of leakage; make sure pipes are properly supported.				
<b>SYSTEM</b>					
Visual	Do a full visual inspection of all system components.				
Functional	Test all functions of the system				
Temperatures	*Verify safe settings on Anti-Scald Valve				
<b>ELECTRICAL</b>					
Smoke and CO detector	*Verify devices are installed and working properly. Change batteries if necessary.				
Circuit Breakers	Check to see that the circuit breaker is clearly labeled. Exercise circuit breaker.				
Connections	Check wire connections. Make sure they are tight.				
<b>ANODE ROD</b>					
	Remove and visually inspect the anode rod. Anode rod should be replaced when more than 6" of core wire is exposed at either end of the rod.				
<b>RELIEF AND DRAIN VALVE</b>					
Relief Valve	Lift and release the relief valve on the water heater. Make certain that the valve operates properly by allowing several gallons to flush through the discharge line. Replace if valve is blocked or does not operate properly. <b>NOTE: DISCHARGED WATER MAY PRESENT A SCALD RISK. TAKE CAUTION WHEN OPERATING RELIEF VALVE.</b>				
Drain Valve	Open the drain valve and drain a few quarts of water from the bottom of the tank to flush any hard water deposits. Replace if valve is blocked or does not operate properly. <b>NOTE: DRAINED WATER MAY PRESENT A SCALD RISK. TAKE CAUTION WHEN OPERATING DRAIN VALVE.</b>				
<b>FINAL INSPECTION</b>					
Check list	Verify that you have completed entire check list. WARNING: FAILURE TO DO SO COULD RESULT IN SERIOUS INJURY OR DEATH				
Homeowner	Review what you have done with the homeowner.				
<b>INITIAL AND DATE AFTER INSPECTION/SERVICE. CONTINUE INSPECTIONS ANNUALLY BEYOND THE FOURTH YEAR.</b>					

Table 4 - \*If applicable to system.

<b>TROUBLESHOOTING</b>	
<b>HOT WATER HAS A ROTTEN EGG ODOR</b>	
<b>PROBLEM</b>	<b>POSSIBLE SOLUTION</b>
Supply water has high sulfate or mineral content	Check with water quality specialist in your area. Have water supply analyzed. Address water quality issues according to specialist's recommendations.
<b>NO HOT WATER</b>	
<b>PROBLEM</b>	<b>POSSIBLE SOLUTION</b>
Zone valve not opening	Check or replace.
Circulator not operating	Check or replace
Tank control set too low	Raise tank temperature* (SEE NOTE BELOW)
Boiler control set too low	Raise boiler temperature
Wiring incorrect	Recheck wiring
Tank control failure	Replace control
Air trap in loop	Purge air
<b>NOT ENOUGH HOT WATER</b>	
<b>PROBLEM</b>	<b>POSSIBLE SOLUTION</b>
Zone valve restriction	1" full bore replace zone valve
Circulator arrow reversed	Reverse circulator
Boiler temperature too low	Raise boiler temperature
Boiler sized too small	Check sizing chart
Tank sized too small	Check sizing chart
Demand flow rate too high	Check sizing chart
	Install mixing valve, raise tank temperature*
	Install flow regulator
Air trap in loop	Purge to remove air
Heat and tank come on together	Recheck wiring or coincidence
	Draw tank down and lower thermostat. Recheck.
Not enough space heat	Boiler sized too small. Consult chart.
Slow recovery	Circulator head capacity too low
<b>T &amp; P VALVE DISCHARGES</b>	
<b>PROBLEM</b>	<b>POSSIBLE SOLUTION</b>
Tank temperature too high	Lower temperature on tank
Water expands when heated	Install expansion tank
Water pressure too high	Install pressure reducing valve
<b>HOT TUBS, SPAS, MULTIPLE SHOWERS, HIGH DEMAND</b>	
<b>PROBLEM</b>	<b>POSSIBLE SOLUTION</b>
Pressure too low	Check line pressure for restriction
Recovery of tank slow	Slow startup boiler. See chart.
	Boiler sized too small. See chart.
	Check flow rate and compare to chart
	Demand too great. Check flow rates and compare to chart. Install mixing valve and/or flow restricting valve and raise tank and boiler temperature*.

Table 5

ITEM NO.	Replacement Part #	Description	QTY.
1	6075P-002	HOT WATER OUTLET	1
2	6075P-001	COLD WATER DIP TUBE, SSC-35	1
3	6075P-053	KAMCO FIBERGLASS INSULATION	1
4	6060P-633	THERMODISC MOUNTING CLIP	1
5	6060P-632	5/16-18 HEX NUT - THERMODISC MOUNTING CLIP	2
6	TD1010	THERMOSTAT CONTROL	1
7	6060P-634	PLASTIC PROTECTIVE COVER	1
8	6060P-187	ELECTRICAL BOX COVER	1
9	6075P-006	#8 X 3/4" SELF TAPPING SCREW	4
10	TP1400	3/4" RELIEF VALVE (80 and 119 gallon models only)	1
11	6060P-630	GREEN GROUND WIRE W/RING	1
12	SN1002	DRAIN VALVE	1
13	6075P-043	MAGNESIUM ANODE ROD	1

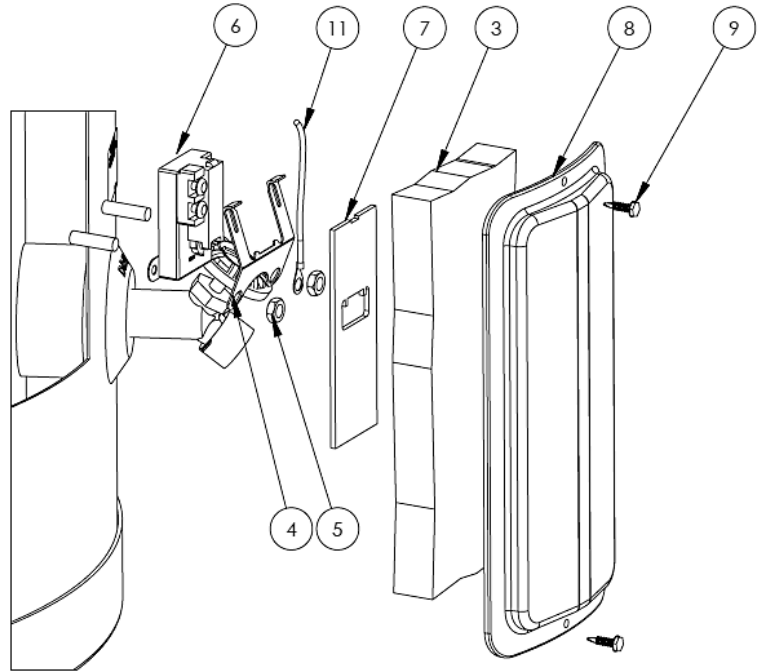
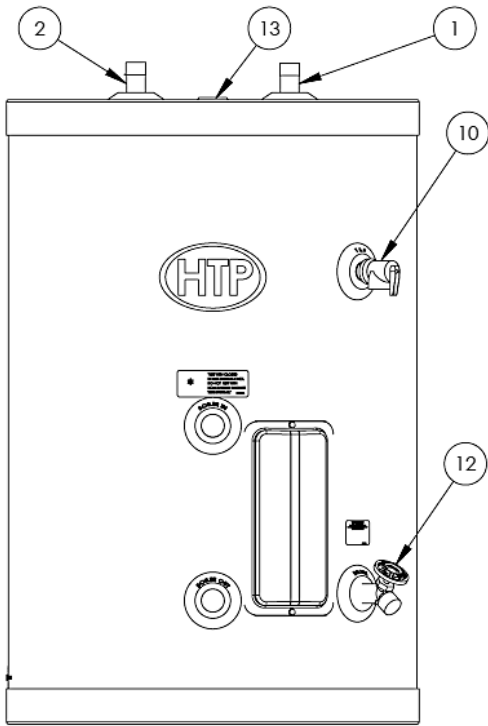
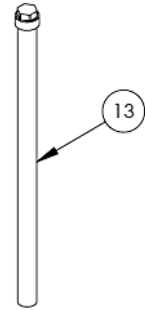

Figure 8 – Parts Blowout

### HTP CUSTOMER INSTALLATION RECORD FORM

The following form should be completed by the installer for you to keep as a record of the installation in case of a warranty claim. After reading the important notes at the bottom of the page, please also sign this document.

Customer's Name:	
Installation Address:	
Date of Installation:	
Installer's Code/Name:	
Product Serial Number(s):	
Comments:	
Installer's Phone Number:	
Signed by Installer:	
Signed by Customer:	

**IMPORTANT:**

**Customer: Please only sign after the installer has reviewed the installation, safety, proper operation, and maintenance of the system. In the case that the system has any problems, please call the installer. If you are unable to make contact, please contact your HTP Sales Representative.**

*Distributor/Dealer: Please insert contact details.*