

Installation, Operation and Maintenance Instructions for

Endurance

EBP Series Modulating Combination Boiler
(natural or propane gas)

EDP Series Modulating Hydronic Boiler
(natural or propane gas)

EDN Series Modulating Boiler, non ferrous
(natural or propane gas)

WARNING

FOR YOUR SAFETY: This product must be installed and serviced by a professional service technician, qualified in hot water boiler installation and maintenance. Improper installation and/or operation could create carbon monoxide gas in flue gases which could cause serious injury, property damage, or death. Improper installation and/or operation will void the warranty. As an additional measure of safety, Laars strongly recommends installation of suitable carbon monoxide detectors in the vicinity of this appliance and in any adjacent occupied spaces.

WARNING

If the information in this manual is not followed exactly, a fire or explosion may result causing property damage, personal injury or loss of life.

Do not store or use gasoline or other flammable vapors and liquids in the vicinity of this or any other appliance.

WHAT TO DO IF YOU SMELL GAS

- Do not try to light any appliance.
- Do not touch any electrical switch; do not use any phone in your building.
- Immediately call your gas supplier from a nearby phone. Follow the gas supplier's instructions.
- If you cannot reach your gas supplier, call the fire department.

Installation and service must be performed by a qualified installer, service agency, or gas supplier.

AVERTISSEMENT

Assurez-vous de bien suivre les instructions données dans cette notice pour réduire au minimum le risque d'incendie ou d'explosion ou pour éviter tout dommage matériel, toute blessure ou la mort.

Ne pas entreposer ni utiliser d'essence ni d'autres vapeurs ou liquides inflammables dans le voisinage de cet appareil ou de tout autre appareil.

QUE FAIRE SI VOUS SENTEZ UNE ODEUR DE GAZ:

- Ne pas tenter d'allumer d'appareils.
- Ne touchez à aucun interrupteur. Ne pas vous servir des téléphones dans le bâtiment où vous vous trouvez.
- Appelez immédiatement votre fournisseur de gaz depuis un voisin. Suivez les instructions du fournisseur.
- Si vous ne pouvez rejoindre le fournisseur de gaz, appelez le service des incendies.

L'installation et l'entretien doivent être assurés par un installateur ou un service d'entretien qualifié ou par le fournisseur de gaz.

TABLE OF CONTENTS

SECTION 1.

General Information

1.1 Introduction..... 3
 1.2 Codes and Standards..... 3
 1.3 Unpacking the Appliance..... 4
 1.4 Locating the Appliance 4
 1.5 Clearances 4

SECTION 2.

Venting Options

2.1 Concentric Direct Vent..... 5
 2.1.1 Concentric Vent Description 5
 2.1.2 Laars Concentric Vent Kits 5
 2.1.3 Horizontal Concentric Vent Location 5
 2.2 Stainless Steel Single Pipe Horizontal and Vertical Vents — Category IV 9
 2.3 Air Source For Combustion (when not ducted to the Endurance) 11
 2.3.1 Air From Inside the Building 11
 2.3.2 All Air From Outdoors 11
 2.3.3 Connecting Special Gas Vent to the Appliance..... 12
 2.4 Non-Concentric Combustion Air 12

SECTION 3.

Gas Piping

3.1 Gas Piping 12
 3.2 Domestic Water Piping (EBP only)..... 13
 3.3 Anti-Freeze — Domestic Water 14

SECTION 4.

Hydronic Heat Piping

4.1 Hydronic Piping 14
 4.2 Using in a Combined Hot Water Heating and Chilled Water Cooling System 17
 4.3 Water Quality and Treatment..... 17
 4.4 Anti-Freeze 17
 4.4.1 Endurance Boiler Low Temperature Feature 17
 4.4.2 Anti-Freeze Boiler Additives 17

SECTION 5.

Electrical Connections

5.1 Electrical Connections 20

SECTION 6.

Using the Boiler Control

6.1 Front Panel Display 22
 6.2 Control Logic 22
 6.3 View Menu 22
 6.4 Setpoint Menu 24
 6.4.1 “SP” Supply Temperature 24
 6.4.2 “PO” Pump Operation..... 24
 6.4.3 “Pd” Pump Delay 24
 6.4.4 “Oar” Outdoor Reset..... 24
 6.4.5 “Oal” Minimum Outdoor Reset Point 25
 6.4.6 “rc” Outdoor Reset Ratio 25
 6.4.7 “oTo” Warm Outdoor Shutdown 25
 6.4.8 “uni” Temperature Units 25

6.4.9 “Add” Control Address 25
 6.4.10 “DiF” Burner On Differential 25
 6.5 Calculated Control Values 25
 6.5.1 ACV Release (EBP only)..... 25
 6.5.2 Tank Charge Setting (EBP only)..... 25
 6.5.3 Burner On Point..... 25
 6.5.4 Modulation Point..... 25
 6.6 Other Control Functions 25
 6.6.1 Using Buttons on Control..... 25
 6.6.2 Alarm Acknowledge 26
 6.6.3 Power On/Off..... 26
 6.6.4 Low Fire Hold 26
 6.6.5 High Fire Hold..... 26
 6.6.6 Pump Operation 26
 6.6.7 Anti-Condense Valve Operation 26
 6.6.8 Field-Supplied Outdoor Reset Controls..... 27

SECTION 7.

Boiler Start Up

7.1 Removal of Boiler From Common Vent..... 27
 7.2 Filling the System 28
 7.3 Firing Burner..... 28

SECTION 8.

Maintenance and Component Description

8.1 Unit Pump..... 29
 8.2 Gas Valve 29
 8.3 Safety Limit Switch 29
 8.4 Boiler Control..... 29
 8.5 Ignition Control 30
 8.6 Ignitor / Flame Sensor Assembly..... 30
 8.7 Transformer 30
 8.8 PMW Board 30
 8.9 Blower..... 30
 8.10 Transfer Tank (EBP) 30
 8.11 Thermostatic Union (EDP/EDN)..... 31
 8.12 Cleaning the Boiler Coil..... 31

SECTION 9.

Servicing

9.1 Sequence of Operation..... 31
 9.2.1 Fault Code Identification..... 33
 9.2.2 Fault Correction 33
 9.2.3 Resolving Lockouts (LO)..... 33

SECTION 10.

Air Orifice and Gas Valve Adjustment

..... 35

SECTION 11.

Symptom Evaluations

11.1 Delayed Ignition..... 35
 11.2 Short Cycling 36
 11.3 Noisy Operation..... 36
 11.4 Insufficient Hot Water (EBP only) 36
 11.5 High Gas Consumption 37

SECTION 12.

Parts Identification

..... 38

SECTION 1. General Information

1.1 Introduction

EBP - This appliance is a low pressure, direct vent, hot water boiler that provides priority domestic hot water on demand as well as hydronic space heating. The unit has a twenty gallon tank which holds boiler water (as opposed to domestic water storage).

The boiler water is kept hot at all times to provide immediate response to call for heat or domestic water. Domestic water is heated by the boiler water through a stainless steel plate heat exchanger.

EDP/EDN - This appliance is a low pressure, direct vent, cold start hot water boiler that provides heat for hydronic space heating. The model number structure is shown in Figure 3.

Both appliances incorporate a circulating pump and a bypass loop, and provide circulation for the heating system and adequate flow for its own needs. It may be necessary to install a system circulator to achieve the required flow rate through the system.

Both appliances feature a forced draft, premixed combustion system. All air for combustion is supplied

with the gas to the burner (flame holder). Both the intake air and the gas are metered through separate orifices before entering the combustion air blower. The blower forces the air/fuel mixture through the flame holder and into the combustion chamber. The mixture is ignited from the hot surface ignitor and burns. Hot gases are forced out between the passes of the heat exchanger into the flue collector. Flue gases are discharged into the outside atmosphere through the vent terminal.

The appliance can operate with a concentric vent system that will provide outside air for combustion. Other venting arrangements can be provided for the appliance to include an alternative 50 equivalent feet maximum horizontal or condensate trapped vertical vent.

1.2 Codes and Standards

The Endurance may be a direct vent or Category IV Boiler. All installations must be made in accordance with:

- The National Fuel Gas Code, ANSI Z223.1/ NFPA 54 latest edition, or
- CSA B149.1 Natural Gas and Propane Installation Code.
- The requirements of the local utility or other authorities having jurisdiction take precedence over the general instructions contained herein.

All electrical wiring is to be done in accordance with:

- The National Electrical Code (NFPA 70), latest edition or

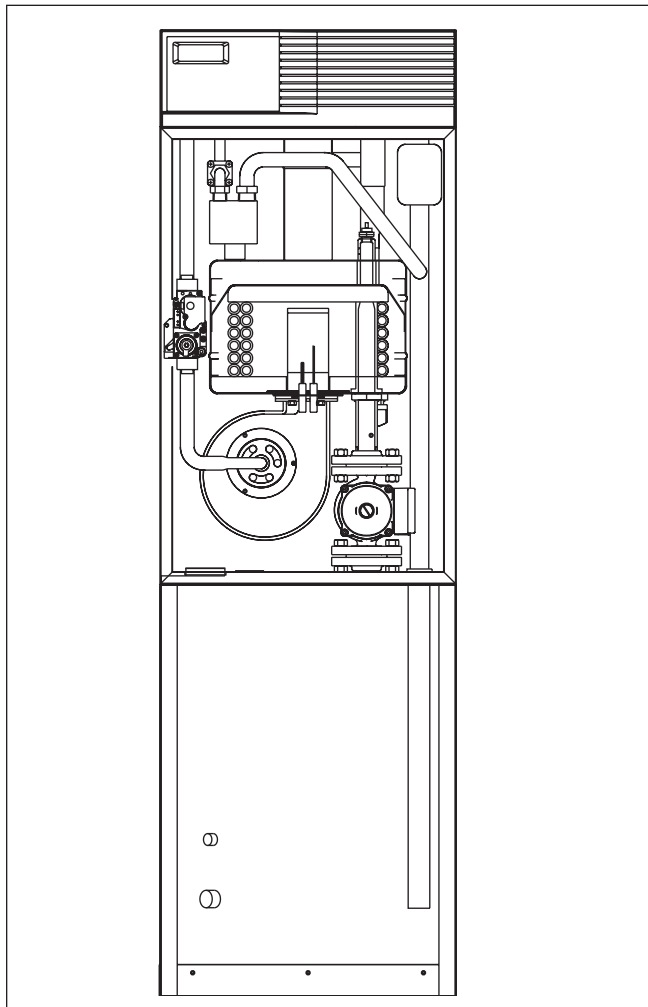

Figure 1. Combo Heating/Domestic Water (Model EBP).

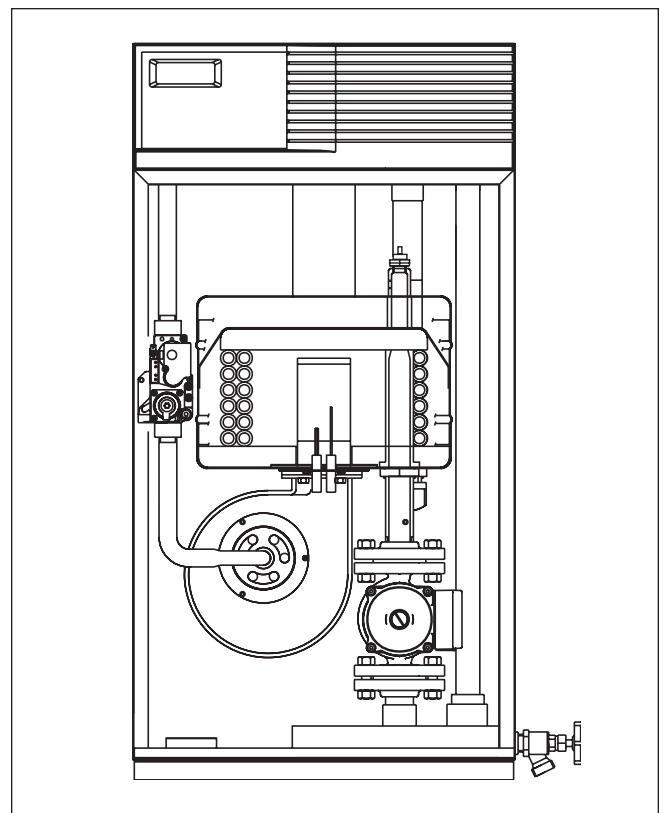

Figure 2. Heating Unit (Model EDP/EDN).

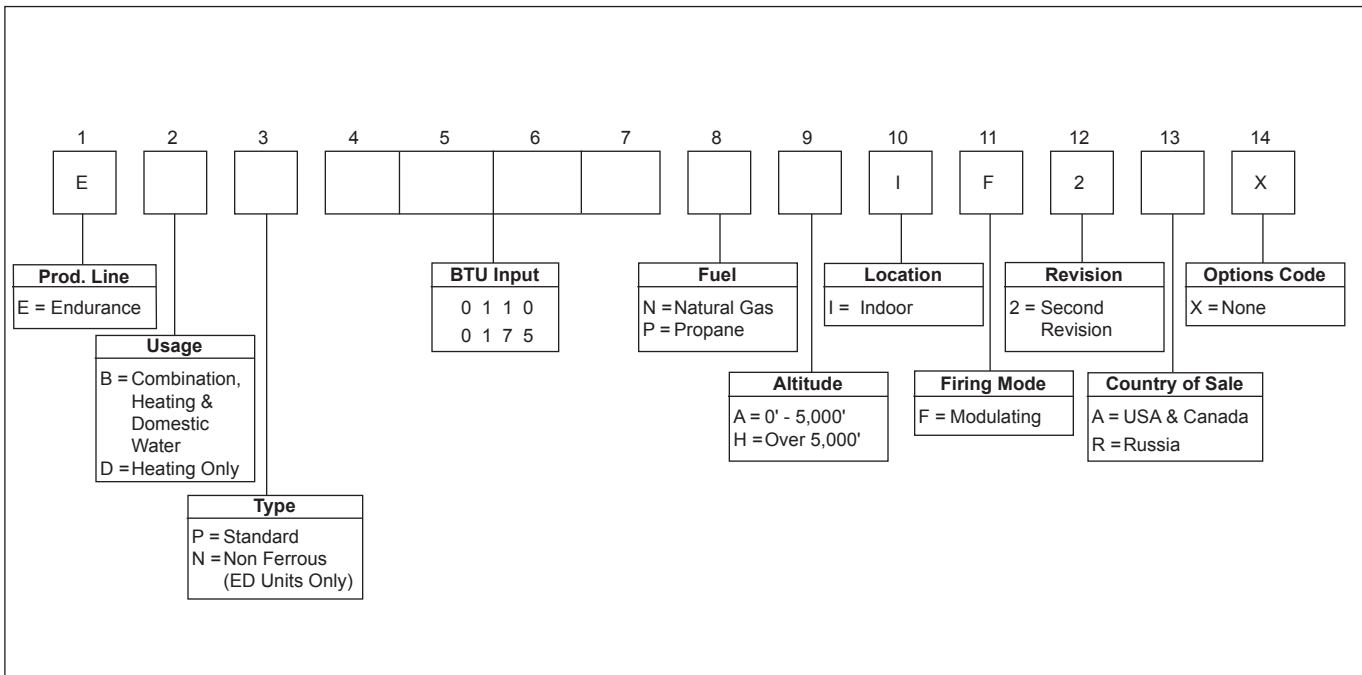

Figure 3. Model Structure.

- b. The Canadian Electrical Code (CSA C22.1), latest edition.
- c. All applicable local installation codes must also be adhered to.

All vent installations must be made in accordance with:

- a. The applicable venting requirements of the National Fuel Gas Code (ANSI Z223.1/NFPA 54), latest edition; or
- b. in Canada, The Natural Gas and Propane Installation Code (CSA B149.1), latest edition.

All applicable provisions of local building codes should also be adhered to.

1.3 Unpacking the Appliance

Remove all packing and tie down materials. Make immediate claims (to the carrier) if the appliance and its packaging are damaged.

1.4 Locating the Appliance

The appliance is designed for installation on combustible flooring, in alcoves, basements, closets, or utility rooms. It must **NOT** be installed on carpeting. **IF INSTALLED IN A FINISHED AREA, PROVISION SHOULD BE MADE FOR DRAINAGE OF ANY ACCIDENTAL SPILLAGE OR LEAKAGE.**

The location for the unit should be chosen with regard to venting dimensions, convenient access to piping, and accessibility for service and cleaning.

The boiler shall be installed so that the gas ignition system components are protected from water (dripping, spraying, rain, etc.) during appliance operation or service (circulator replacement, control replacement, etc.).

1.5 Clearances

The dimension and criteria in Table 1 should be followed when choosing the location for the unit.

Minimum Clearances From Combustible Materials		
Back	1 inch	25mm
Left Side	1 inch	25mm
Right Side	1 inch	25mm
Front	1 inch	25mm
Top (Alcove Install)	1 inch	25mm
Top (Closet Install)*	22 inches	559mm
Vent: Concentric, Direct	0 inch	0mm
Vent: Category	3 inches	76mm
Suggested Serviceability Clearances		
Front	18 inches	457mm
Left Side	6 inches	152mm
Right Side	6 inches	152mm

*Minimum closet height 6'9" 206 cm

Table 1. Clearances.

**SECTION 2.
Venting Options**

The Endurance boilers are certified as direct vent, sealed combustion boilers, when vented using one of the following two methods:

- 1) Concentric direct vent, which has a flue gas pipe inside a combustion air pipe.
- 2) Non-concentric direct vent, using separate pipes for the flue gases and the combustion air.

The Endurance boilers can also take air from the space (when properly sized), and be vented as a Category IV appliance.

The following sections describe the requirements for each of these methods.

IMPORTANT NOTE REGARDING ENDURANCE VENTING: Regardless of the venting arrangement being used, the flue gas vent material used with the Endurance **MUST** be stainless steel special gas vent listed to U.L. Standard 1738 and U.L.C. Standard 636. Endurance flue gases must never be vented into a masonry chimney or vented with B-vent or other galvanized vent material. Endurance units are not permitted to be common vented with any other appliance(s), including other Endurance appliances.

2.1 Concentric Direct Vent

2.1.1 Concentric Vent Description

Endurance concentric direct vent is a sealed-combustion system. It can be used for vent systems with a maximum of 15 linear feet (4.6m) and three elbows. All of the air is drawn in from the outside through a 5" stainless steel outer pipe. Flue gases are vented through a 3" stainless steel pipe that is positioned inside the 5" intake pipe. Hot flue gases are surrounded by the intake flow of cooler outdoor air (see Figure 4). Laars offers two concentric vent kits, described in section 2.1.2. Laars concentric vents may be installed through, and be in contact with, combustible materials.

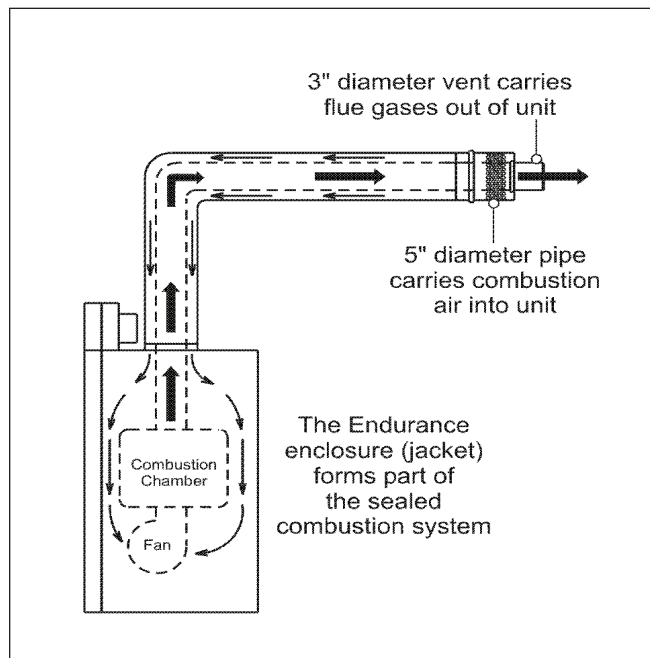

Figure 4. Combustion Air and Flue Gas Paths.

2.1.2 Laars Concentric Vent Kits

The Endurance is certified with a maximum of 15 linear feet (4.6m) of concentric piping and three sets of elbows. There are two concentric vent kits offered by Laars. Both kits, and all Laars Endurance vent material meet the requirements of U.L. Standard 1738 and U.L.C. Standard 636. The horizontal vent kit

is part number 2400-009. The vertical vent kit is part number 2400-011. See Figures 5 and 6, which show the components included with the kits and venting configurations. Installation instructions are included with the kits. Rules for concentric venting, vent material and vent terminal placement are discussed in the rest of section 2 of this manual.

For additional length, and/or fittings, to extend the kits to maximum 15 linear feet (4.6m) and three elbows, individual components are available. These components are shown in Figure 7.

2.1.3 Horizontal Concentric Vent Location

The centerline of the vent opening must be at least 16-1/2" (42cm) above grade, outside. Should it be impossible to locate the opening centerline 16-1/2" (42cm) above grade, use optional concentric vent terminal extension (part number 2400-428), shown in Figure 7.

In the U.S., vent terminals must be at least 3 feet (0.9m) above any forced air inlet located within 10 feet (3.0m). In Canada, vent terminals must be at least 6 feet (1.8m) from any forced air inlet.

In the U.S., a direct vent terminal must be at least 12" (30cm) from any window or door that may be opened, or any other nonmechanical opening. For an Endurance that is not direct vented (vented as Category IV), the vent terminal must be at least 4 feet (1.2m) below or to the side of, and 12" (30cm) above any such opening.

In Canada, a direct vent or non-direct vent terminal must be at least 36" (91cm) from any window or door that may be opened, or any other non-mechanical opening.

The vent opening should be well away from shrubbery or other obstructions that would prevent free air flow to and from the vent terminal.

If the vent terminal location chosen is less than 18" (46cm) below an overhang, the 3" vent pipe must extend to the outside edge of the overhang, to prevent the accumulation of flue gas (see Figure 9). Accumulating flue gas can contaminate the combustion air, causing nuisance lockouts of the ignition system. In addition, accumulation of flue gases can settle on, and damage the structure's surfaces.

Vent terminals must not terminate in a location where condensate or vapor may be a nuisance, hazard, or could be a detriment to other equipment. See Figure 8 for more detail concerning vent terminal placement in the U.S. and Canada.

Do not locate the vent terminal where blockage by snow is a possibility, or where flue products could strike against building materials and cause degradation.

When multiple Endurance units are used, the concentric vent terminals may be side-by-side,

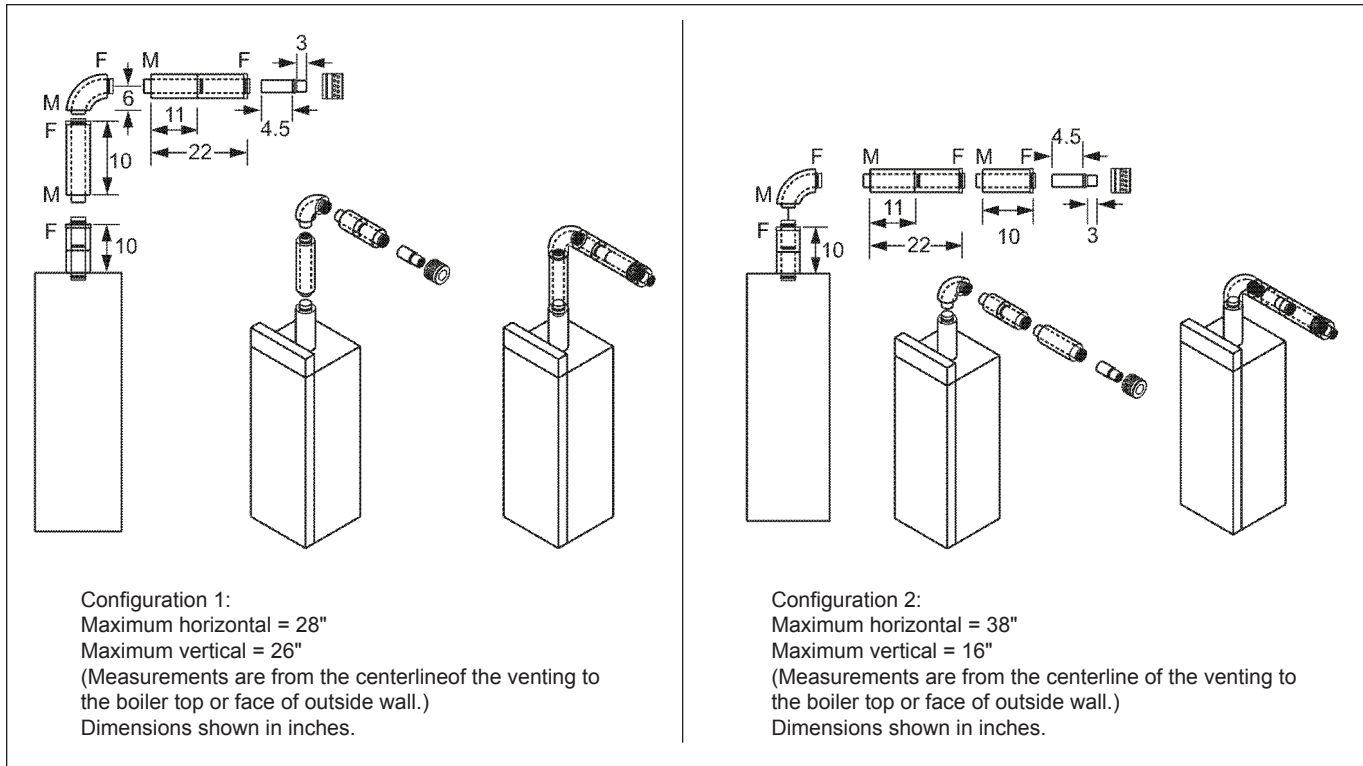

Figure 5. Horizontal Vent Kit 2400-009.

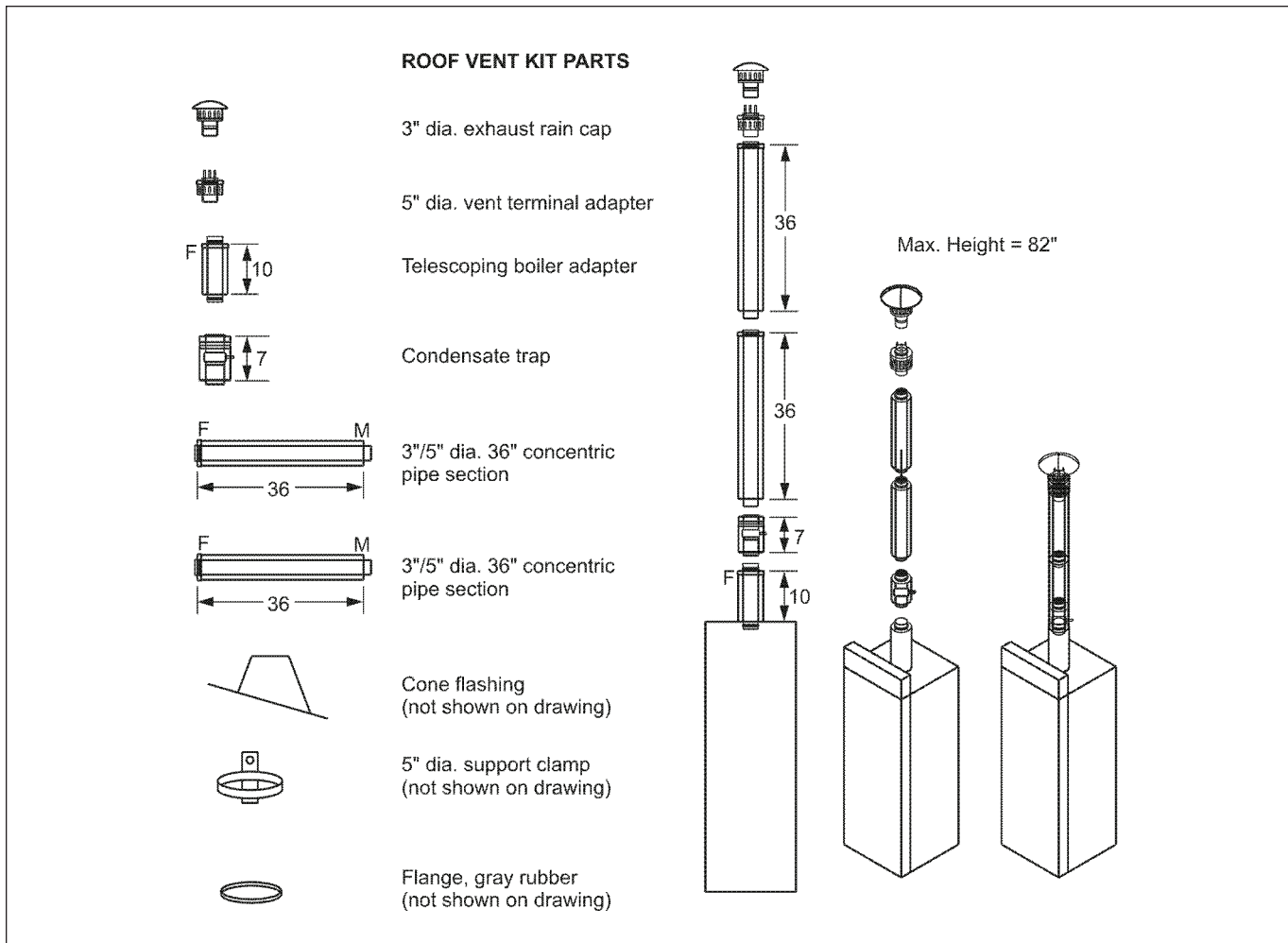

Figure 6. Vertical Vent Kit 2400-011.

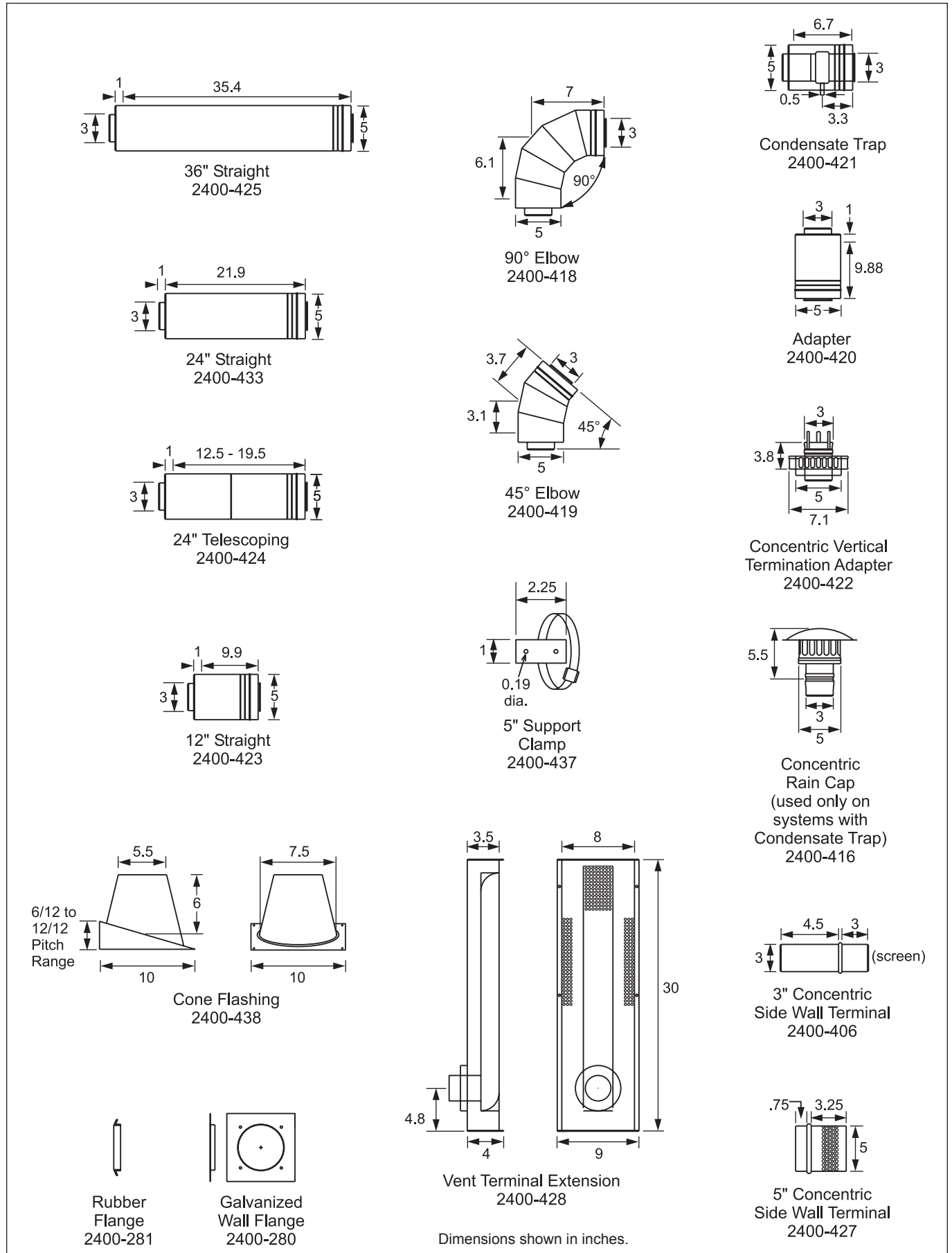
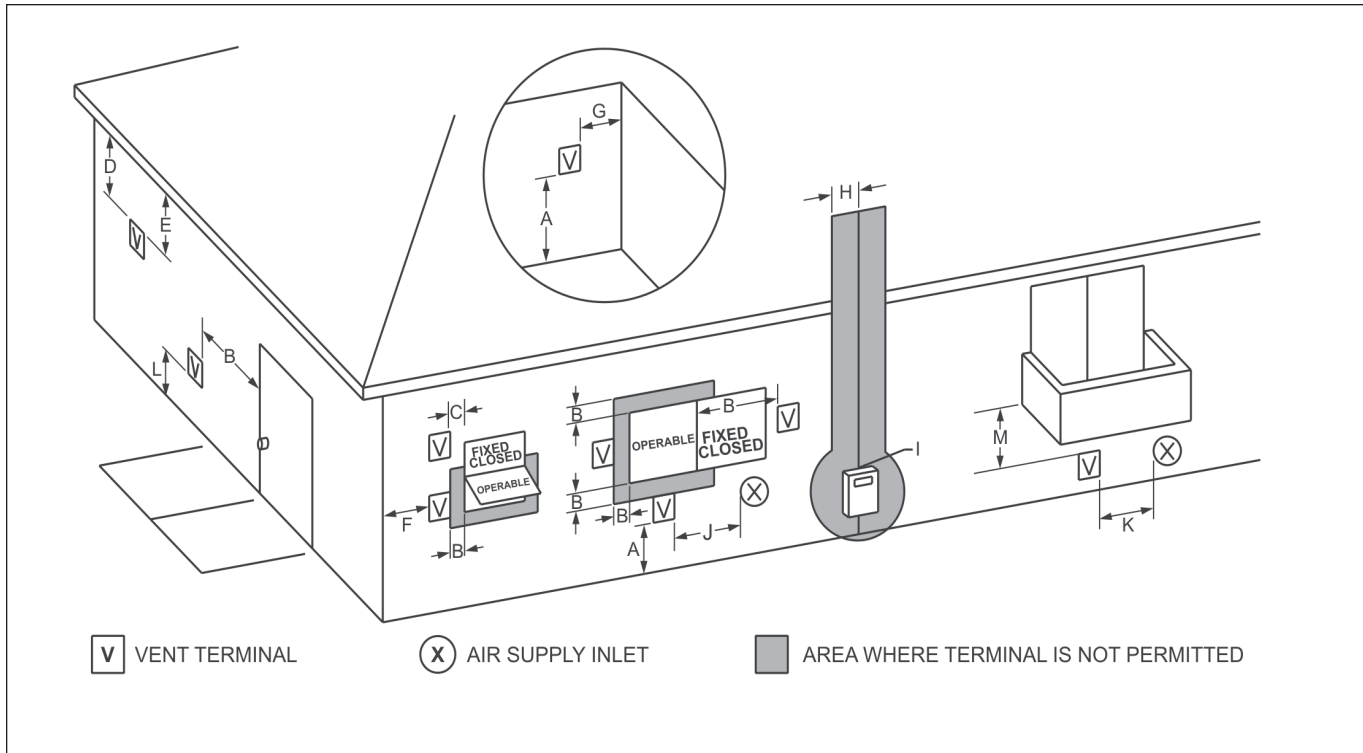

Figure 7. Concentric Vent Parts.



	U.S. Installations (see note 1)	Canadian Installations (see note 2)
A= Clearance above grade, veranda, porch, deck, or balcony	12 inches (30 cm)	12 inches (30 cm)
B= Clearance to window or door that may be opened	Direct Vent Only: 12 inches (30 cm) Other Than Direct Vent: 4 feet (1.2 m) below or to side of opening; 1 foot (30 cm) above opening	36 inches (91 cm)
C= Clearance to permanently closed window	See note 4	See note 5
D= Vertical clearance to ventilated soffit located above the terminal within a horizontal distance of 2 feet (61cm) from the center line of the terminal	See note 4	See note 5
E= Clearance to unventilated soffit	See note 4	See note 5
F= Clearance to outside corner	See note 4	See note 5
G= Clearance to inside corner	See note 4	See note 5
H= Clearance to each side of center line extended above meter/regulator assembly	See note 4	3 feet (91 cm) within a height 15 feet above the meter/regulator assembly
I= Clearance to service regulator vent outlet	See note 4	3 feet (91 cm)
J= Clearance to nonmechanical air supply inlet to building or the combustion air inlet to any other appliance	Direct Vent Only: 12 inches (30 cm) Other Than Direct Vent: 4 feet (1.2 m) below or to side of opening; 1 foot (30 cm) above opening	36 inches (91 cm)
K= Clearance to a mechanical air supply inlet	3 feet (91 cm) above if within 10 feet (3 m) horizontally	6 feet (1.83 m)
L= Clearance above paved sidewalk or paved driveway located on public property	Vent termination not allowed in this location	Vent termination not allowed in this location
M= Clearance under veranda, porch, deck, or balcony	See note 4	12 inches (30 cm) (see note 3)
Notes:		
1. In accordance with the current ANSI Z223.1 / NFPA 54 National Fuel Gas Code.		
2. In accordance with the current CAN/CGA-B149 Installation Codes.		
3. Permitted only if veranda, porch, deck, or balcony is fully open on a minimum of two sides beneath the floor.		
4. For clearances not specified in ANSI Z223.1 / NFPA 54, clearance is in accordance with local installation codes and the requirements of the gas supplier.		
5. For clearances not specified in CAN/CGA-B149, clearance is in accordance with local installation codes and the requirements of the gas supplier.		

Figure 8. Vent Terminal Clearance.

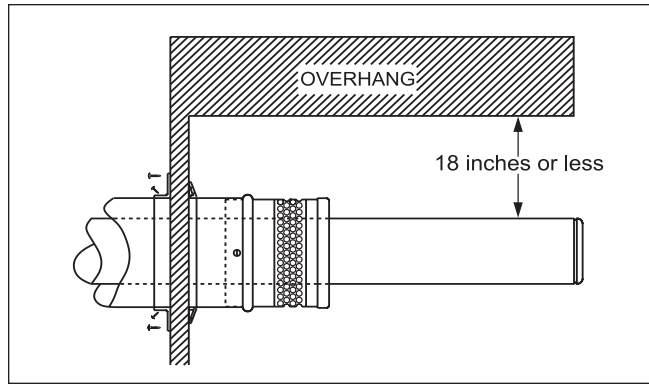

Figure 9. Clearance from Overhang.

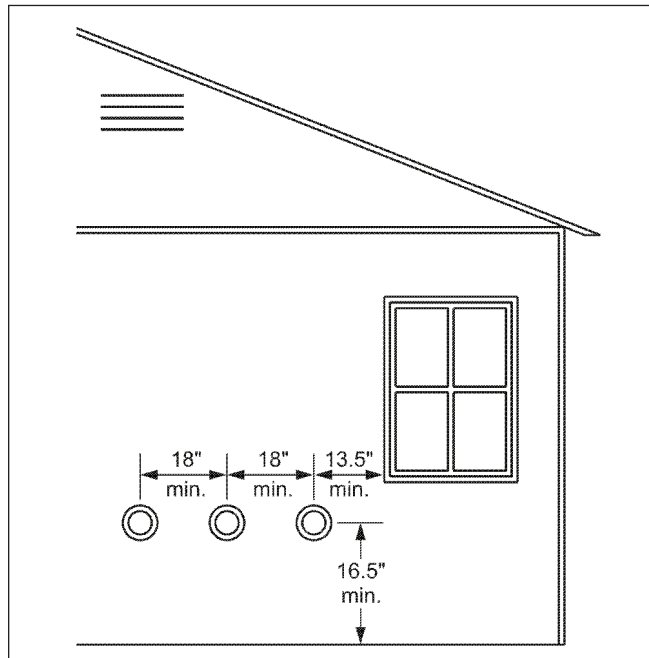

Figure 10. Multiple Concentric Vent Clearances.

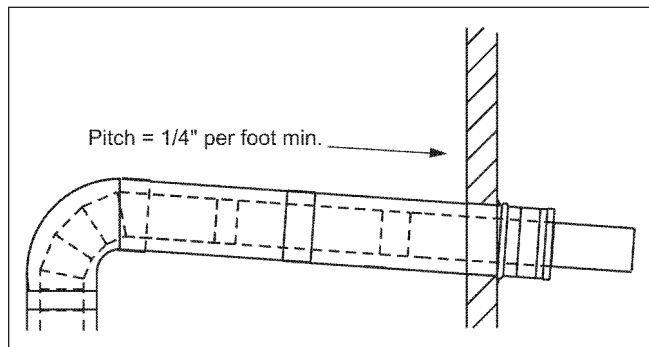

Figure 11. Vent System Pitch.

provided that they are at least 18" (46cm) apart, centerline to centerline (see Figure 10).

A horizontal vent system must pitch downward, toward the terminal and away from the Endurance, as shown in Figure 11. It must pitch at least 1/4" per foot (21mm per meter). Be sure to take this into consideration when choosing the vent terminal location.

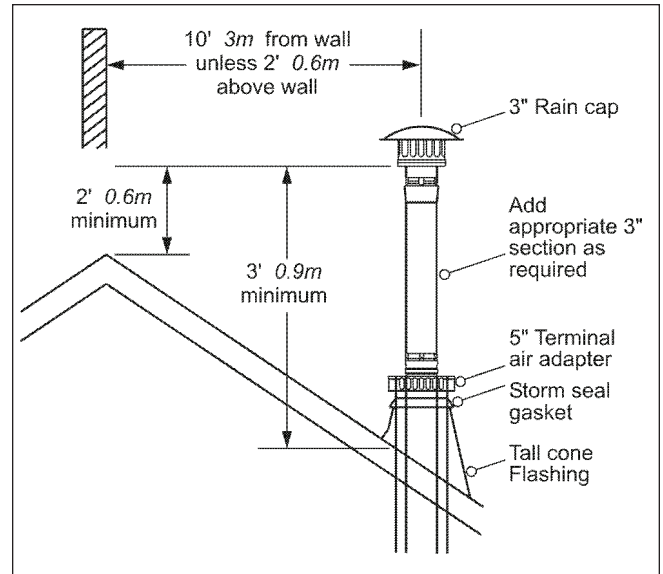

Figure 12. Vertical Vent Terminal Placement.

The vertical vent terminal must be placed such that the bottom of the vent cap is at least 2-feet (0.6m) above any structure (such as the peak of a roof or adjacent wall) within 10 feet (3.0m), and must be at least 3 feet (0.9m) above where the vent pipe exits the roof (see Figure 12).

When vertical vent systems have horizontal components, they must have a condensate drip tee in the offset. All horizontal portions of the vent system must slope a minimum 1/4" per foot toward the condensate drip tee. Laars vertical vent kit and individual venting components have condensate tees that work in a vertical vent system, and therefore it is not necessary to have an offset in a vertical vent system that uses these parts.

2.2 Stainless Steel Single Pipe Horizontal and Vertical Vents – Category IV

Stainless steel special gas vent listed to U.L. Standard 1738 and U.L.C. Standard 636 must be used to vent all models. Three-inch or 4-inch material can be used. Vent pipe and fittings are manufactured to these standards by HeatFab, Inc. under the trade name of Saf-T Vent®, by Z-Flex™ under the trade name of Z-Vent®, and by ProTech Systems, Inc. under the trade name FasNSeal®. Follow the special gas vent manufacturer's instructions regarding design, location and assembly of the vent system.

The appliance may be vented with any number of elbows or fittings, providing that the maximum equivalent feet of venting is not exceeded. Equivalent feet of vent material is shown in table 2, along with information about vent temperature and pressure. Elbows (90°) in the vent system shall be considered to be 5 equivalent feet (1.5m).

A horizontal vent system must pitch downward, toward the terminal and away from the Endurance, as shown in Figure 11. It must pitch at least 1/4"

3" Non-Concentric Vent Parts

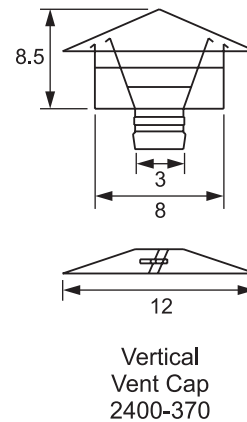
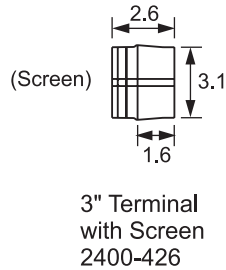
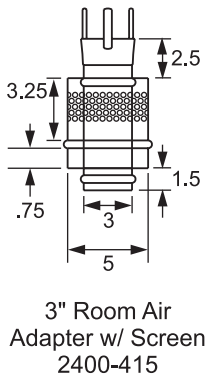
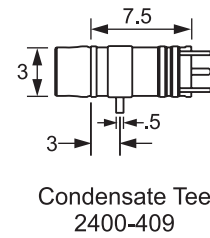
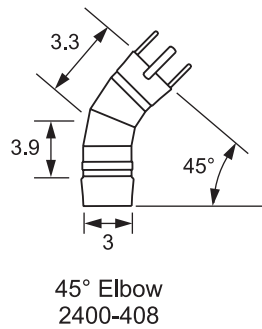
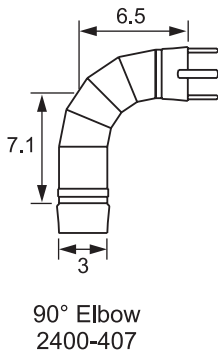
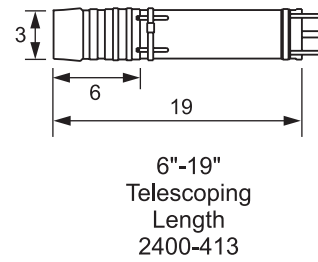
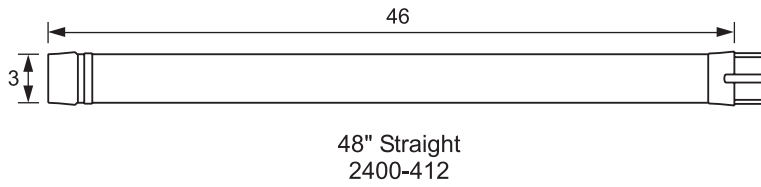
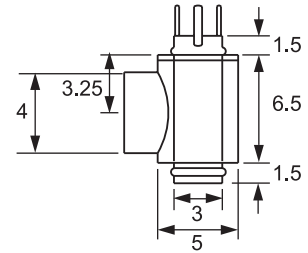
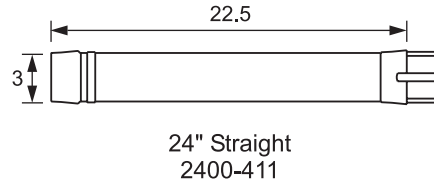
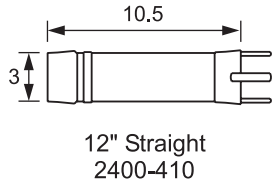

Dimensions shown in inches.

Figure 13. 3" Vent Parts.

Minimum clearance from combustibles (vent) U.S.*	3"	8cm
Minimum clearance from combustibles (vent) Canada	6"	15cm
Max. flue gas temp.	325°F	163°C
Max vent pressure	1.5" w.c.	0.4kPa
Max. equivalent ft. of 3" venting (any combination of horizontal or vertical)	50 equiv. feet	15 equiv. meters
Max. equivalent ft. of 4" venting (any combination of horizontal or vertical)	100 equiv. feet	30 equiv. meters
*Note: To use 3" (8cm) clearance, the vent must be open on at least one side. If fully enclosed, clearance is 6" (15cm)		

Table 2. Category IV Vent Parameters.

per foot (21mm per meter). Be sure to take this into consideration when choosing the vent terminal location.

For applications requiring vertical venting through a roof, the same limitations for length and fittings apply (see Table 2). Vertical vents greater than 7 feet (2.1m) in length must use a condensate trap.

When vertical vent systems have horizontal components, they must have a condensate drip tee in the offset. All horizontal portions of the vent system must slope a minimum 1/4" per foot toward the condensate drip tee. Laars vertical vent kit and individual venting components have condensate tees that work in a vertical vent system, and therefore it is not necessary to have an offset in a vertical vent systems that use these parts.

The vertical vent terminal must be placed such that the bottom of the vent cap is at least 2-feet (0.6m) above any structure (such as the peak of a roof or adjacent wall) within 10 feet (3.0m), and must be at least 3 feet (0.9m) above where the vent pipe exits the roof (see Figure 12).

Laars offers 3" vent parts for non-concentric venting, including an in-line condensate tee and vent caps for vertical venting. See Figure 13 for 3" vent parts, and Figure 15 for an example of the inline condensate in a vertical vent system.

IMPORTANT NOTE REGARDING ENDURANCE VENTING: Regardless of the venting arrangement being used, the flue gas vent material used with the Endurance MUST be **stainless steel** special gas vent listed to U.L. Standard 1738 and U.L.C. Standard 636. Endurance flue gases must **never** be vented into a masonry chimney or vented with B-vent or other galvanized vent material. Endurance units are **not** permitted to be common vented with any other appliance(s), including other Endurance appliances.

2.3 Air Source For Combustion (when not ducted to the Endurance)

When using Category IV venting methods the appliance draws all combustion air through its top and from the adjacent space. When locating the appliance

in unconfined spaces in buildings, infiltration may be adequate to provide air for combustion and ventilation. However, in buildings of unusually tight construction, or when locating the appliance in a confined space, additional air should be provided and the guidelines below must be followed:

2.3.1 Air From Inside the Building

The following method shall be used to size the air openings for boilers that are getting all of their combustion air from inside the building.

The confined space shall be provided with **two** permanent openings communicating directly with other spaces of sufficient volume so that the combined volume of all such spaces meets the criteria for an unconfined space. The total input of all gas utilization equipment installed in the combined spaces shall be used to determine the required minimum volume. **Each** opening shall have a minimum free area of not less than 1 in.²/1000 Btu/hr (220 mm²/kW) of the total input rating of all gas utilization equipment in the confined space, but not less than 100 in.² (645 cm²). One opening shall commence within 12 in. (30 cm) of the top, and one opening shall commence within 12 in. (30cm) of the bottom, of the enclosure. The minimum dimension of air openings shall be not less than 3 in. (8 cm).

2.3.2 All Air From Outdoors

When all air is provided from outdoors, but not ducted directly to the Endurance, the following methods shall be used to size the air opening(s).

- a. **Two** permanent openings, one commencing within 12 in. (30 cm) of the top and one commencing within 12 in. (30 cm) of the bottom, of the enclosure shall be provided. The openings shall communicate directly, or by ducts, with the outdoors or spaces (crawl or attic) that freely communicate with the outdoors.
 - a1. Where directly communicating with the outdoors or where communicating to the outdoors through vertical ducts, **each** opening shall have a minimum free area of 1 in.²/4000 Btu/hr (550 mm²/kW) of total input rating of all equipment in the enclosure.
 - a2. Where communicating with the outdoors through horizontal ducts, **each** opening shall have a minimum free area of not less than 1 in.²/2000 Btu/hr (1100 mm²/kW) of total input rating of all equipment in the enclosure.
- b. One permanent opening, commencing within 12 in. (30 cm) of the top of the enclosure, shall be permitted where the equipment has clearances of at least 1 in. (2.5 cm) from the sides and back and 6 in. (16 cm) from the front of the appliance.

The opening shall directly communicate with the outdoors or shall communicate through a vertical or horizontal duct to the outdoors or spaces that freely communicate with the outdoors and shall have a minimum free area of:

- b1. 1 in.²/3000 Btu/hr (700 mm²/kW) of total input rating of all equipment in the enclosure, **and**
- b2. Not less than the sum of the areas of all vent connectors in the confined space.

2.3.3 Connecting Special Gas Vent to the Appliance

When drawing combustion air from the adjacent space, part number 2400-415 (room adapter with screen) can be used. One portion of this assembly connects to the 5" air collar (with a screen for the combustion air) and the other part connects to the 3" flue opening (see Figure 14). The rest of the 3" vent system can be connected to the adapter within the 2400-415.

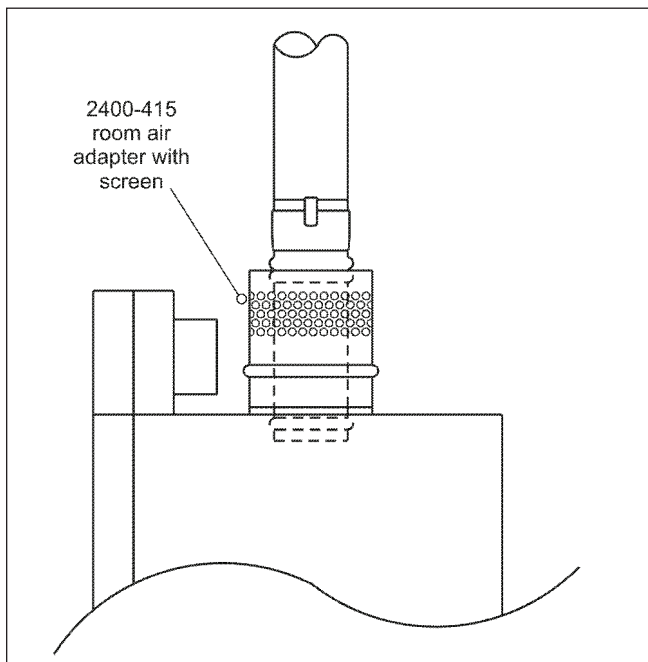

Figure 14. Combustion Air from Room.

2.4 Non-Concentric Combustion Air

An alternate, non-concentric combustion air source may be installed (as shown in Figure 15), provided that the minimum 4" diameter combustion air duct does not exceed 15' (4.6m). Termination should include an air screen and be located in a qualified air space (see Section 2.3) or outside.

Separated combustion air / flue gas may be considered either "mechanical draft" or "direct vent". To be considered "direct vent", all of the combustion air and flue gas piping must be sealed stainless steel special gas vent, listed to U.L. 1738 and U.L.C. 636.

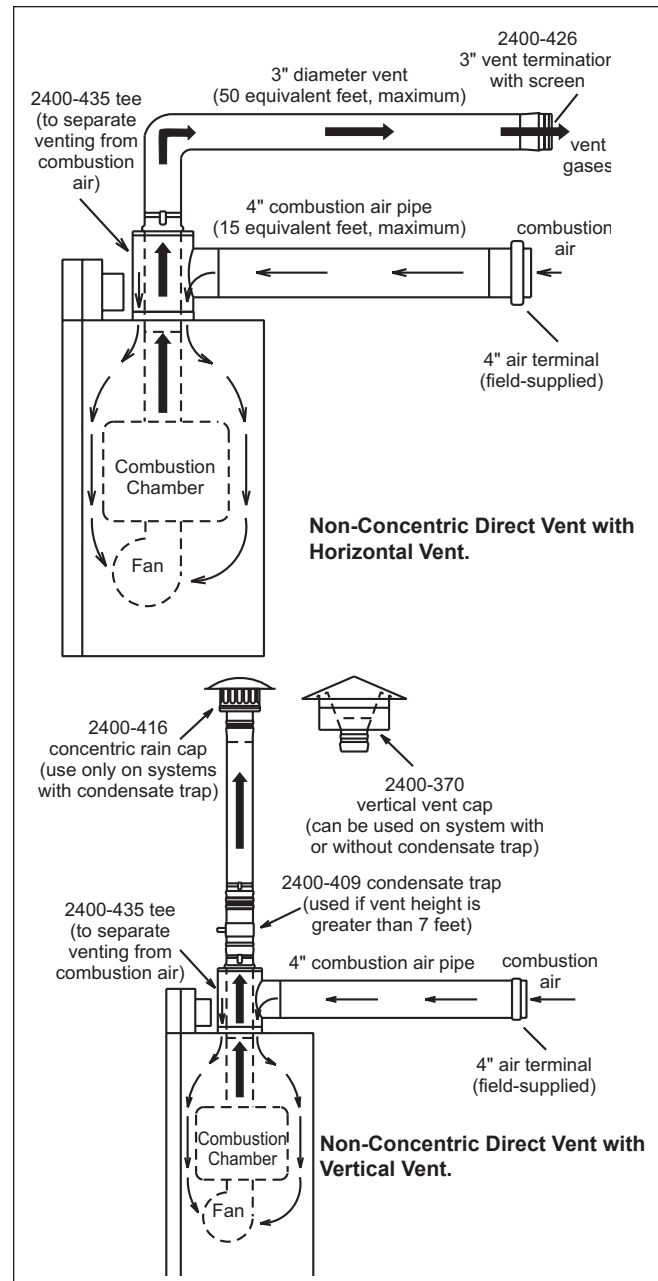

Figure 15. Non-Concentric Combustion Air.

When the system meets this requirement, vent terminal clearances may be less than that of a non-direct vent system. See Figure 8 for direct vent terminal clearances.

The combustion air pipe may be galvanized material, but if used, the system is a "mechanical vent" system, and the vent terminal clearances must be per the rules for "mechanical vent" systems. See Figure 8.

SECTION 3.

3.1 Gas Piping

The appliance requires an inlet gas pressure of at least 4" w.c. (1.0kPa) and no greater than 13" WC

Length of Pipe		Capacity of Pipe							
		1/2"		3/4"		1"		1-1/4"	
ft.	m	MBTU/h	kW	MBTU/h	kW	MBTU/h	kW	MBTU/h	kW
10	3	132	38.7	278	81.5	520	152.4	1050	307.7
20	6.1	92	27	190	55.7	350	102.6	730	213.9
30	9.1	73	21.4	152	44.5	285	83.5	590	172.9
40	12.2	63	18.5	130	38.1	245	71.8	500	146.5
50	15.2			115	33.7	215	63	440	128.9
75	22.9			93	27.2	175	51.3	360	105.5
100	30.5			79	23.1	150	44	305	89.4
150	45.7			64	18.8	120	35.2	250	73.3
Additional length to be added for each tee or elbow									
		ft	m	ft	m	ft	m	ft	m
		1.3	0.4	1.7	0.5	2.2	0.7	2.7	0.8

Table 3. Gas Pipe Sizing.

(3.2kPa). Check with your local gas utility or supplier for availability of this pressure range.

Refer to Table 3 to size the supply piping to minimize pressure drop between meter or regulator and unit.

1. Run gas supply line in accordance with all applicable codes.
2. Locate and install manual shutoff valves in accordance with state and local requirements.
3. Install drip leg, ground joint union and drip cap to trap sediment and for test gauge access.
4. Support all piping with proper hangers.
5. All threaded joints should be coated with piping compound resistant to the action of liquefied petroleum gas.
6. The boiler and its individual shutoff valve must be disconnected from the gas supply piping system during any pressure testing of that system at test pressures in excess of 1/2 psig (3.5kPa).
7. The boiler must be isolated from the gas supply piping system by closing its individual manual shutoff valve during any pressure testing of the gas supply piping system at test pressures equal to or less than 1/2 psig (3.5kPa)
8. The boiler and its gas connection must be leak tested before placing the boiler in operation.
9. Purge all air from gas lines.

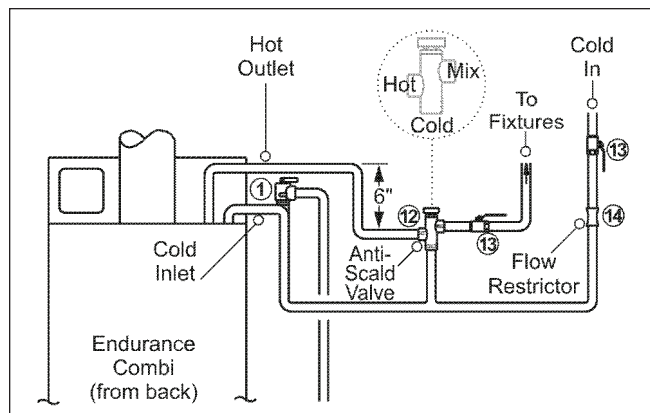

Figure 16. Domestic Water Piping.

3.2 Domestic Water Piping (EBP only)

1. Connect tempering (mixing) valve (12) “Hot” port to hot water outlet from unit. This valve should be rated no higher than 120°F mixed delivery temperature or as local codes dictate. LAARS RECOMMENDS ANTI-SCALD TEMPERING (MIXING) VALVES (see Figure 16).
2. Connect gate or shutoff valve (13) to tempering (mixing) valve (12) “MIX” port, and cold water inlet.
3. Install supplied flow restrictor (14) ahead of tempering (mixing) valve tee.
4. Connect pressure relief valve (1) (if required by codes), rated at maximum 150 PSI as close to the unit as possible. No other valves or restrictions may be installed between the Endurance and the relief valve.

DO NOT USE A TEMPERATURE/PRESSURE RELIEF VALVE AS THIS IS NOT A STORAGE HOT WATER HEATER.

NOTE: Installations with water containing 10 or more grains of hardness, must be installed with appropriate water treatment.

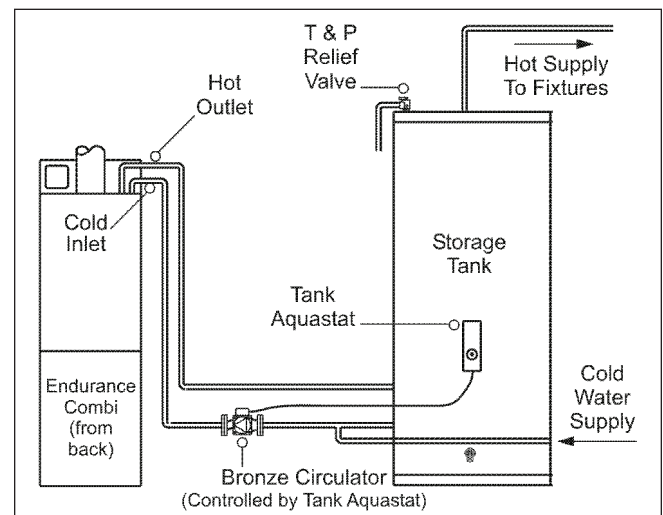

Figure 17. Domestic Water Piping With Storage Tank.

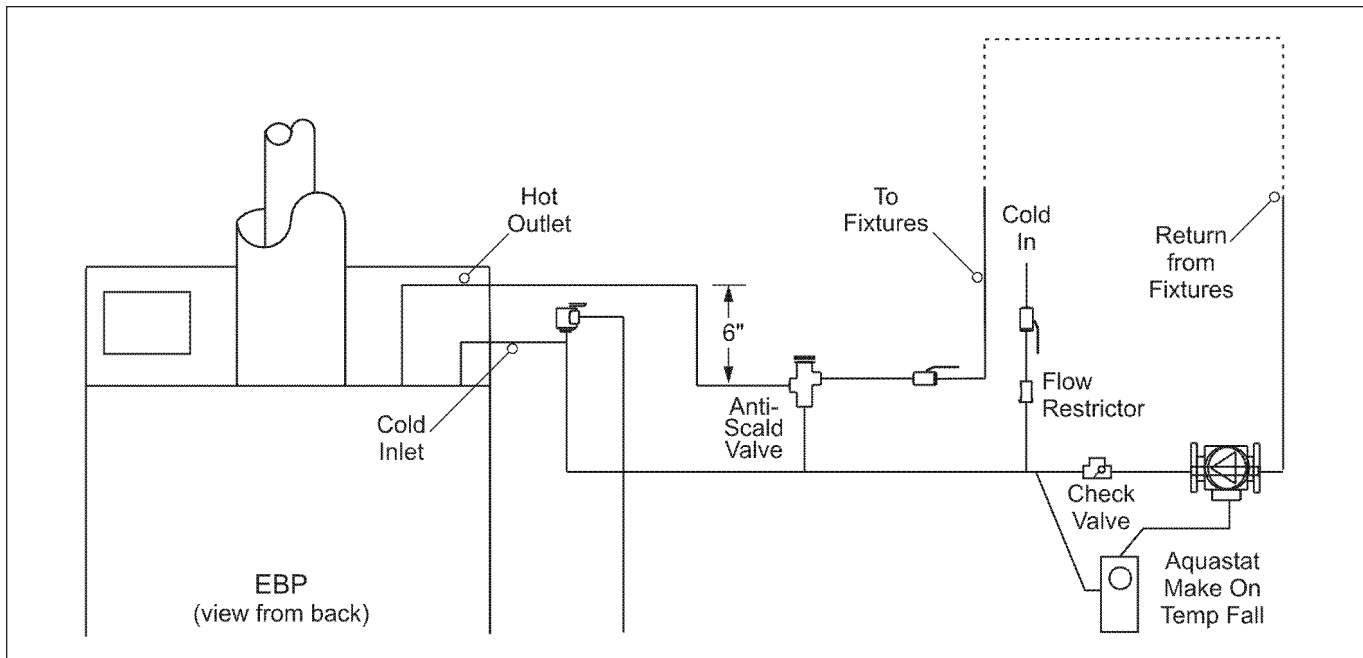

Figure 18. EBP Domestic Water Piping with Recirculating Loop.

⚠ WARNING

Failure to install a hot water tempering (mixing) valve (12) creates a scalding hazard with potential for serious bodily injury. Some brands of tempering (mixing) valves are not designed as anti-scald valves.

Where domestic water is supplying multiple apartments or large whirlpool tubs, an additional storage tank may be connected as shown in Figure 17. The bronze circulator shown must be connected to the tank aquastat and must not run continuously. If the circulator is wired to run continuously, the unit's domestic water flow switch will keep the unit in domestic water priority, and no water will be allowed to be sent to the heating system.

Where domestic water is supplying a recirculating loop, pipe per Figure 18. If the circulator is wired to run continuously, the unit's domestic water flow switch will keep the unit in domestic water priority, and no water will be sent to the heating system. Wire the loop's circulator through an aquastat to maintain domestic water priority, while still allowing the heating systems to function properly.

3.3 Anti-Freeze — Domestic Water

Endurance EBP units use a flat plate heat exchanger to heat domestic (potable) water indirectly. Endurance units are equipped with a Low Temperature control feature that recognizes when the boiler water temperature (not the domestic/potable water temperature) has fallen below 39° (4°C). If this condition is recognized, the Endurance pump will run for 5 minutes, or until the boiler water temperature reaches 45°F (7°C). If the boiler water temperature remains below 45°F (7°C) for 5 minutes, the appliance will start its ignition sequence, in hopes of firing, and

heating the boiler water. The display will show [ICE] during this time.

This feature is intended to assist in protecting the boiler from freezing conditions, and does not help to protect any other part of the boiler or water heater system. This feature will not help to protect the domestic (potable) water in the system from freezing conditions.

⚠ Caution

Power outage, interruption of gas supply, failure of system components, activation of safety devices, etc., may prevent a heater from firing. **Any time a heater is subjected to freezing conditions, and the heater is not able to fire, and/or the water is not able to circulate, there is a risk of freezing in the heater or in the pipes in the system.** When water freezes, it expands. This can result in bursting of pipes in the system, or damage to the heater, which could result in leaking or flooding conditions.

SECTION 4. Hydronic Heat Piping

4.1 Hydronic Piping

The appliance incorporates its own circulating pump and bypass loop and is capable of providing flow through heating zones, in addition to what it needs for itself. Model size 110 is capable of providing flow for two heating zones (up to 67 feet of ¾" baseboard each), and model 175 is capable of providing flow for four heating zones (up to 67 feet of ¾" baseboard, each).

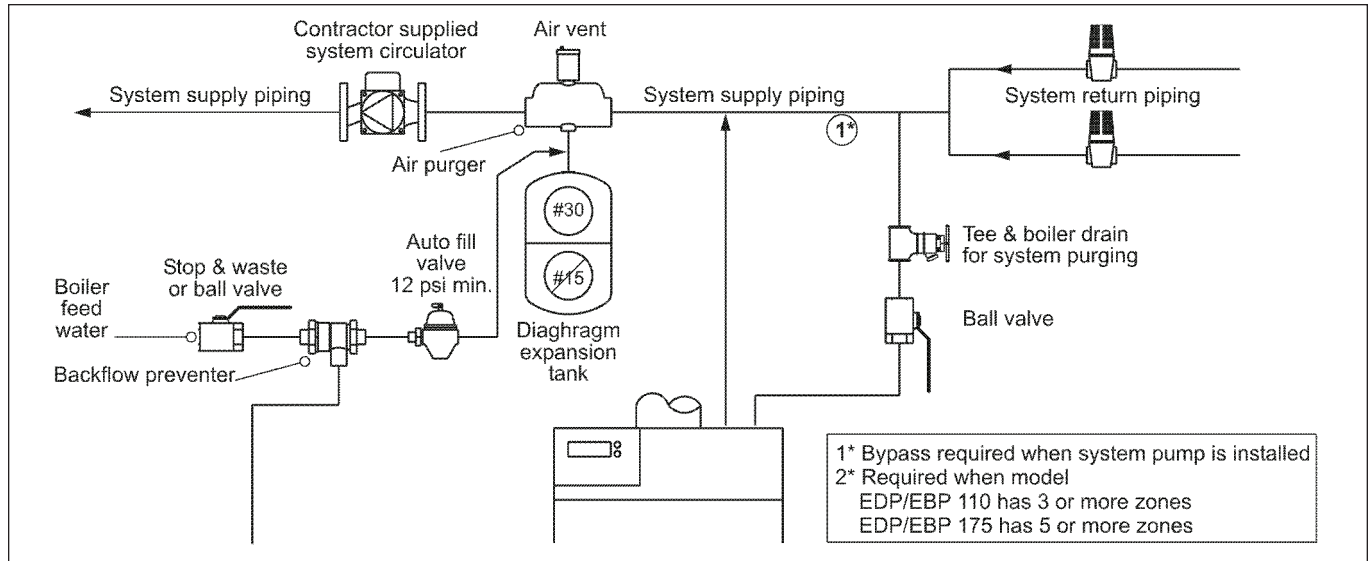

Figure 19. Hydronic Piping EDP/EBP with Zone Valves.

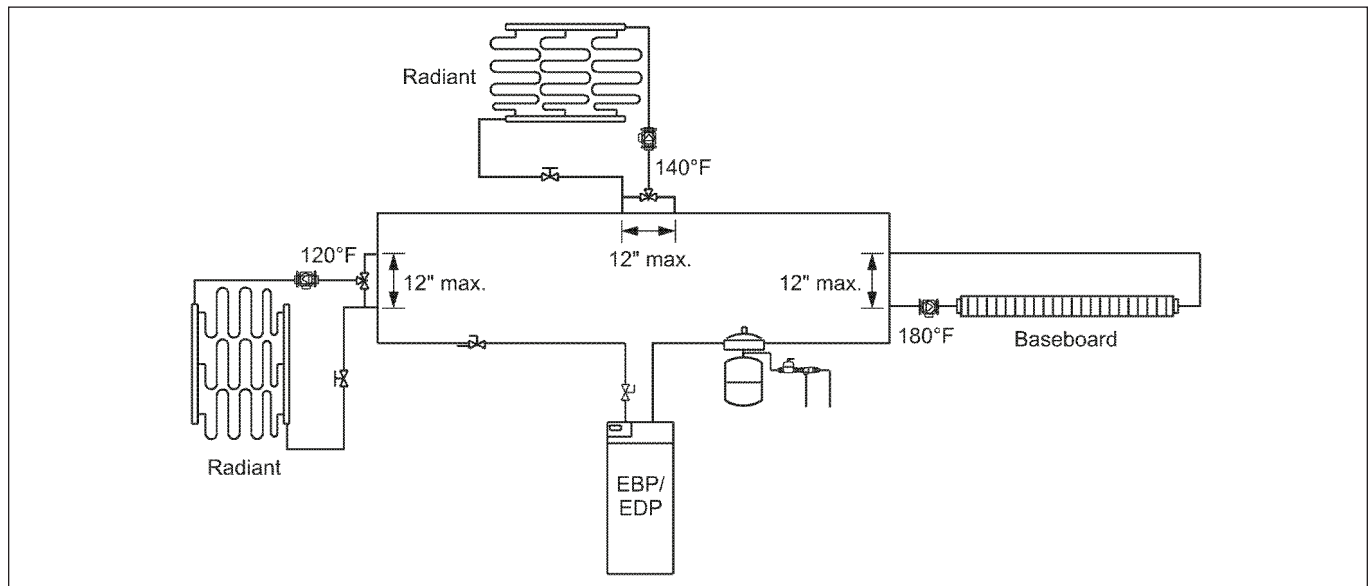

Figure 20. Piping, Single EDP/EBP Boiler for Multiple Temperature Systems.

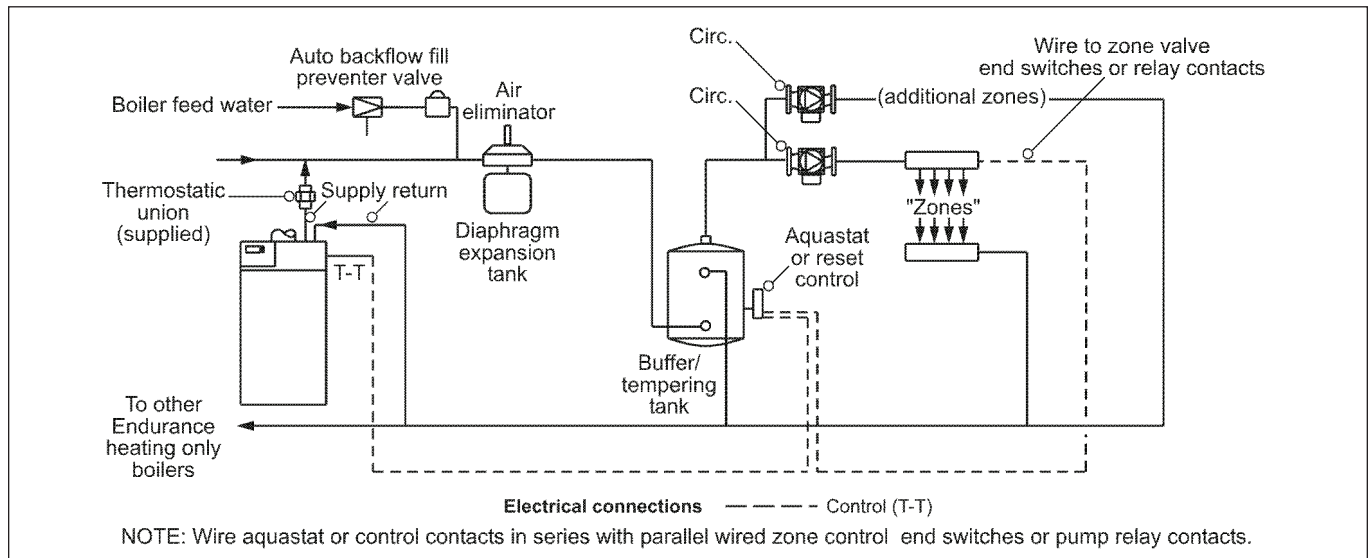

Figure 21. Piping, Model "EDP/EDN" for Radiant Floor.

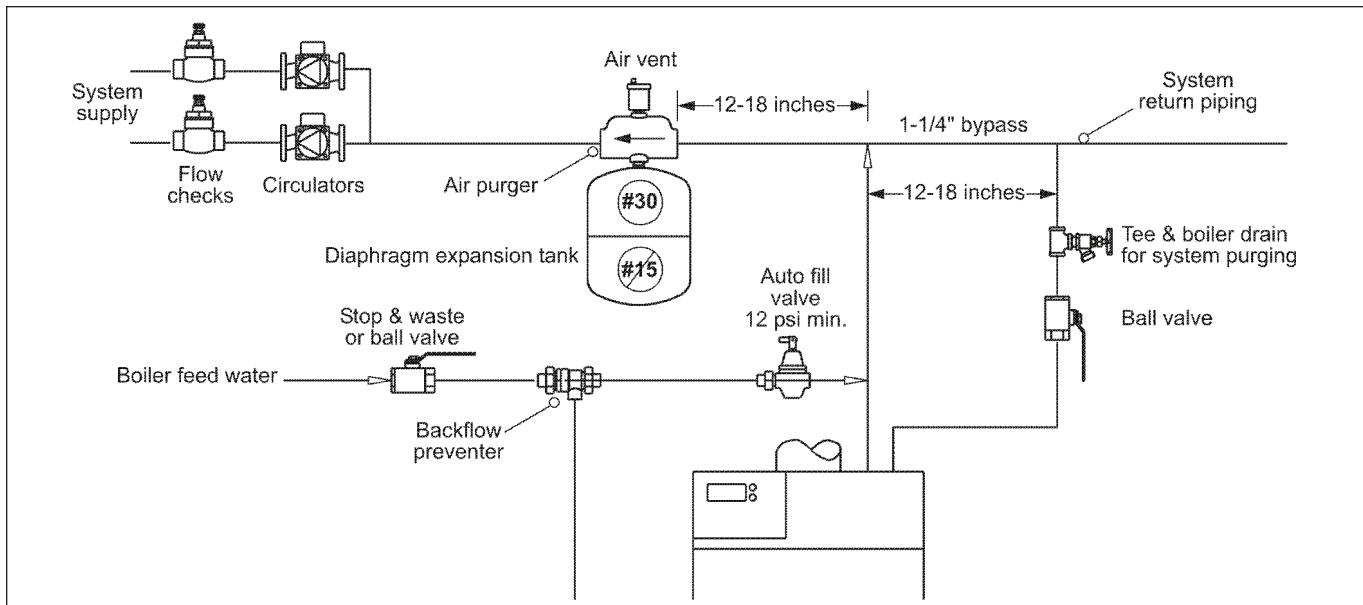

Figure 22. Hydraulic Piping EBP/EDP for Systems Zoned with Circulators.

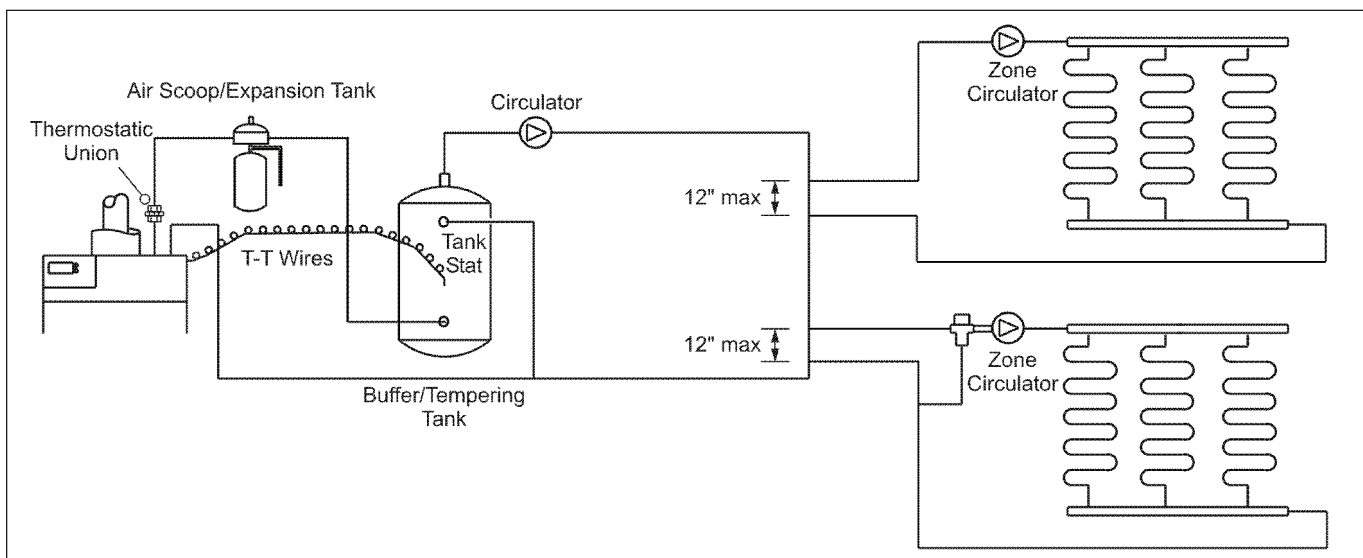

Figure 23. Hydraulic Piping EDP for Low-Temp and/or Multi-Temp Systems.

EDP/EDN boilers installed in radiant (in floor) systems and other low mass boilers should be provided with a buffer/blender tank to assure a controlled supply temperature, and to prevent short cycling. In radiant systems utilizing 3-way tempering valves, a bypass pipe must be installed between supply and return piping.

1. EBP ONLY: Connect system supply to 1¼" supply connection marked "SUPPLY".
2. EDP/EDN ONLY: Connect 1¼" thermostatic union to system supply connection in direction designated with union.
3. Pipe the discharge of the relief valve, full size, to a drain or in a manner to prevent injury in the event of pressure relief.
4. Install an air purger in flow supply line as shown in piping diagrams.
5. Install automatic float type air vent on air scoops.

6. Install a diaphragm expansion tank in boiler outlet piping. To ensure sufficient expansion volume for the hydronic system water, due to heat-up and cool-down during normal operation, a #30 or larger expansion tank must be used on EBP combo units.

NOTE: Never install expansion tank and auto fill valve on return.

7. If necessary, install a properly sized circulator with optional isolation valves in supply beyond expansion tank.

Caution

To avoid the risk of fire which can result in property damage, all hot water pipes must be installed with a minimum 1" (25mm) clearance from combustible materials.

8. Connect boiler feed water supply with shut off valve to inlet connection of automatic fill valve. Locate in boiler outlet piping.
9. If codes require, install suitable back flow preventer between automatic fill valve and city main.
10. The appliance may be installed in single and multiple zone systems (using either zone valves or zone circulators) in the same manner as any other residential boiler.

Caution

The EBP/EDP appliance must not be direct connected to a heating system utilizing oxygen permeable tubing (see warranty). Provide a water to water heat exchanger between systems to prevent corrosion of tank or other components. Non-toxic heating system antifreeze may be added to the hydronic system provided that the concentration does not exceed 35% and the antifreeze contains an anti foamant.

4.2 Use in a Combined Hot Water Heating and Chilled Water Cooling System

When the appliance is used in connection with a refrigeration system, it must be installed so that the chilled medium is piped in parallel with the boiler with appropriate valves to prevent the chilled medium from entering it.

The boiler piping system of an appliance connected to heating coils located in air handling units where they may be exposed to refrigerated air circulation must be equipped with flow control valves or other automatic means to prevent gravity circulation of the boiler water during the cooling cycle.

4.3 Water Quality and Treatment

Water quality control is steadily increasing in importance in view of the use of modern regulation technology and the modern boiler designs used in central heating systems.

The life of a central heating boiler can be severely diminished as a result of the formation of scale deposits and/or corrosion products. The formation of such deposits should be prevented wherever possible.

Continual water make-up is not permitted.

A suitable water treatment may be used to prevent excessive scale deposits in the boiler and corrosion in the system.

4.4 Anti-Freeze

Proper precautions for freeze protection are recommended for boiler installations in areas where the danger of freezing exists.

4.4.1 Endurance Boiler Low Temperature Feature

Endurance boilers are equipped with a Low Temperature control feature that recognizes when the water temperature at the outlet of the boiler has fallen below 39°F (4°C). If this condition is recognized, the Endurance pump will run for 5 minutes, or until the boiler outlet temperature reaches 45°F (7°C). If the boiler outlet temperature remains below 45°F (7°C) for 5 minutes, the appliance will start its ignition sequence, in hopes of firing the boiler and heating the water. The display will show [ICE] during this time.

This feature is intended to assist in protecting the boiler from freezing conditions, and does not help to protect any other part of the heating system. This feature will only help when there is power to the boiler and when the internal water flow components in the Endurance are working properly. This feature will not be able to prevent freezing if the low temperature water condition persists. See Section 4.4.2 for information concerning further freeze protection for the Endurance.

4.4.2 Anti-Freeze Boiler Additives

Caution

Power outage, interruption of gas supply, failure of system components, activation of safety devices, etc., may prevent a boiler from firing. **Any time a boiler is subjected to freezing conditions, and the boiler is not able to fire, and/or the water is not able to circulate, there is a risk of freezing in the boiler or in the pipes in the system.** When water freezes, it expands. This can result in bursting of pipes in the system, or damage to the boiler, which could result in leaking or flooding conditions.

Do not use automotive anti-freeze. When the Endurance is the combination space heating domestic water model (EBP), a non-toxic anti-freeze, such as propylene glycol, must be used. Maintaining a mixture of minimum 65% water and maximum 35% properly inhibited HVAC glycol, which contains an anti-foamant, is the preferred method of freeze protection for Endurance boilers. **Percentage of glycol used in the Endurance boiler must not exceed 35%.** Typically, this mixture will serve as burst protection for temperatures down to approximately -35°F (-30°C).

IMPORTANT NOTES: Different glycol products may provide varying degrees of protection. Glycol products must be maintained properly in a heating system, or they may become ineffective. Consult the glycol specifications, or the glycol manufacturer, for information about specific products, maintenance of solutions, and set up according to your particular conditions.

FOR YOUR SAFETY READ BEFORE OPERATING

⚠ WARNING

If you do not follow these instructions exactly, a fire or explosion may result, causing property damage, personal injury or loss of life.

- A. This appliance does not have a pilot. It is equipped with an ignition device which automatically lights the burner. Do not try to light the burner by hand.
- B. BEFORE OPERATING smell all around the appliance area for gas. Be sure to smell next to the floor because some gas is heavier than air and will settle on the floor.
- WHAT TO DO IF YOU SMELL GAS
- Do not try to light any appliance.
 - Do not touch any electric switch; do not use any phone in your building.
 - Immediately call your gas supplier from a neighbor's phone. Follow the gas supplier's instructions.
- C. If you cannot reach your gas supplier, call the fire department.
- C. Switch Gas Shutoff Switch to "ON" (switch is located on left side of Combination Gas Control – see sketch below).
- D. Do not use this appliance if any part has been under water. Immediately call a qualified service technician to inspect the appliance and to replace any part of the control system and any gas control which may have been under water.

OPERATING INSTRUCTIONS

1. STOP! Read the safety information above on this label.
2. Set the thermostat to lowest setting.
3. Turn off all electric power to the appliance.
4. This appliance is equipped with an ignition device which automatically lights the burner. Do not try to light the burner by hand.
5. Remove front cover.
6. Switch Gas Shutoff Switch to "OFF".
7. Wait five (5) minutes to clear out any gas. If you then smell gas, STOP! Follow "B" in the safety information above on this label. If you don't smell gas, go to next step.
8. Switch Gas Shutoff Switch to "ON".
9. Replace front cover.
10. Turn on all electric power to appliance, depress on/off button on control panel, depress black button on top of control panel.
11. Set thermostat to desired setting.
12. If the appliance will not operate, follow the instructions "To Turn Off Gas To Appliance" and call your service technician or gas supplier.

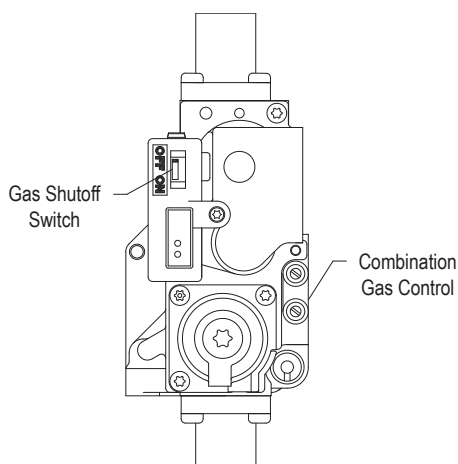

TO TURN OFF GAS TO APPLIANCE

1. Set the thermostat to lowest setting.
2. Turn off all electric power to the appliance if service is to be performed.
3. Remove front cover.
4. Switch Gas Shutoff Switch to "OFF".
5. Replace front cover.

PAR MESURE DE PRUDENCE, LISEZ CE QUI SUIT AVANT DE FAIRE FONCTIONNER L'APPAREIL



MISE EN GARDE

Si vous ne suivez pas ces instructions à la lettre, un incendie ou une explosion pourrait se produire et causer des dommages matériels, des blessures personnelles ou même la mort.

- A. Cet appareil n'est pas doté d'une veilleuse. Il est équipé d'un dispositif d'allumage qui allume automatiquement le brûleur. Ne tentez pas d'allumer le brûleur manuellement.
- B. AVANT D'UTILISER, vérifiez s'il n'y a pas d'odeur de gaz près de l'appareil. Vérifiez s'il n'y a pas d'odeur de gaz près du plancher, car le gaz est plus lourd que l'air et peut se déposer sur le plancher.
- QUE FAIRE EN CAS D'ODEUR DE GAZ
- N'essayez pas d'allumer n'importe quel appareil que ce soit.
 - Ne touchez pas à un commutateur électrique. N'utilisez pas le téléphone de votre résidence.
 - Appelez immédiatement votre fournisseur de gaz en utilisant le téléphone de votre voisin. Suivez les instructions de votre fournisseur de gaz.
- C. Interrupteur d'ouverture de la soupape de détente des gaz (l'interrupteur est situé sur le côté gauche de la commande de gaz multifonctions – voir le croquis ci-dessous)
- D. N'utilisez pas cet appareil si l'une des pièces a été plongée sous l'eau. Communiquez immédiatement avec un technicien de service qualifié afin qu'il inspecte l'appareil et remplace toute pièce du système de commande et toute commande de gaz qui aurait été plongée sous l'eau.

NOTICE D'UTILISATION

1. ARRÊTEZ ! Lisez l'information de sécurité ci-dessus, sur cette étiquette.
2. Réglez le thermostat au réglage le plus bas.
3. Coupez l'alimentation électrique à l'appareil.
4. Cet appareil est doté d'un dispositif d'allumage qui allumera automatiquement le brûleur. Ne tentez pas d'allumer le brûleur manuellement.
5. Retirez le couvercle avant.
6. Interrupteur de fermeture de la soupape de détente des gaz.
7. Attendez cinq (5) minutes afin que le gaz se dissipe. Si vous croyez sentir une odeur de gaz, ARRÊTEZ ! Reportez-vous aux instructions B ci-dessus, sur cette étiquette. S'il n'y a pas d'odeur de gaz, passez à la prochaine étape
8. Interrupteur d'ouverture de la soupape de détente des gaz".
9. Remplacez le couvercle avant.
10. Rétablissez l'alimentation électrique à l'appareil, appuyez sur le bouton «on/off» qui se trouve sur le panneau de commande, appuyez sur le bouton noir qui se trouve sur le panneau de commande.
11. Réglez le thermostat à la température désirée.
12. Si l'appareil ne fonctionne pas, suivez les directives relatives à la fermeture de l'alimentation en gaz et communiquez avec votre technicien de service ou le fournisseur de gaz.

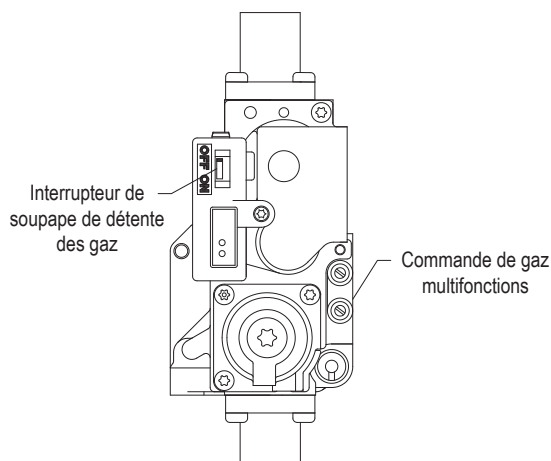

FERMETURE DE L'ALIMENTATION EN GAZ

1. Réglez le thermostat au réglage le plus bas.
2. Coupez toute alimentation électrique à l'appareil si celui-ci doit faire l'objet d'un entretien.
3. Retirez le couvercle avant.
4. Interrupteur de fermeture de la soupape de détente des gaz.
5. Remplacez le couvercle avant.

SECTION 5. Electrical Connections

5.1 Electrical Connections

All electrical wiring must conform to local codes and/or the latest edition of the National Electric Code (NEC; NFPA 70) or the Canadian Electric Code, Part 1 (CEC; CSA C22.1). Any applicable local codes must also be adhered to.

The unit must be electrically grounded in accordance with the requirements of the authority having jurisdiction or, in the absence of such requirement, with the latest edition of the National Electric Code (NEC; NFPA 70) or the Canadian Electric Code, Part 1 (CEC; CSA C22.1). Any applicable local codes must also be adhered to.

Single pole switches, including those of safety control and protective devices must not be wired in a grounded line.

All electrical connections are made through the electrical knockouts on the control panel. The knockout on the right side of the control panel can be used to mount a wiring box, if desired.

NOTE: All internal electric components have been pre-wired. No attempt should be made to connect electric wires to any other location except the wiring box as described below.

1. Main power: Connect a fused 120 volt supply (15 amp) to the main power switch (see Figure 24) (hot leg is connected directly to switch). Neutral leg to white wire. Ground wire can be connected to the grounding screw in the box or on the switch.
2. For single zone installations: (If external pump is required, e.g., because of large system pressure drop) connect room thermostat wires to the red and white/red wires. Connect circulator (120 volt, 5 amps maximum) between the blue wire and the white wire (neutral) (see Figure 25). Note that the blue/white pump wire connects to a dry

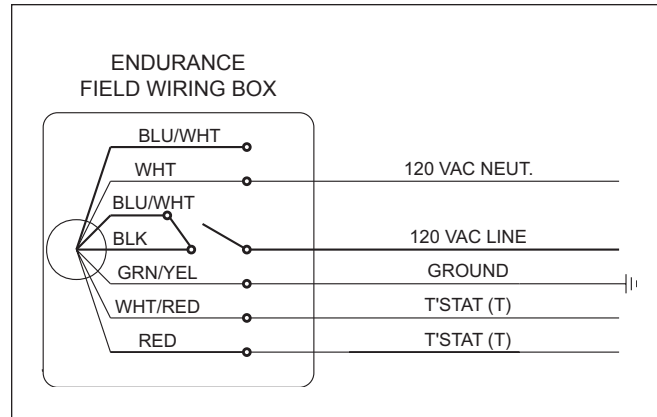

Figure 24. Single Zone With Room Thermostat (internal pump provides system flow).

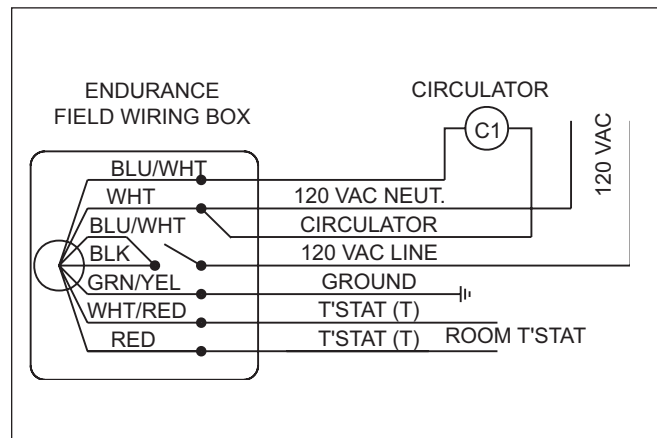

Figure 25. Single Zone with Added Circulator(s) and Room Thermostat(s).

contact. The line voltage and pump wire must be connected per the wiring figures, or the pump may not be energized.

3. Zone Valves and Thermostats: Install external 24 volt transformer of sufficient V.A. to power combined load of zone valves. Consult zone valve manufacturer's instructions. Connect

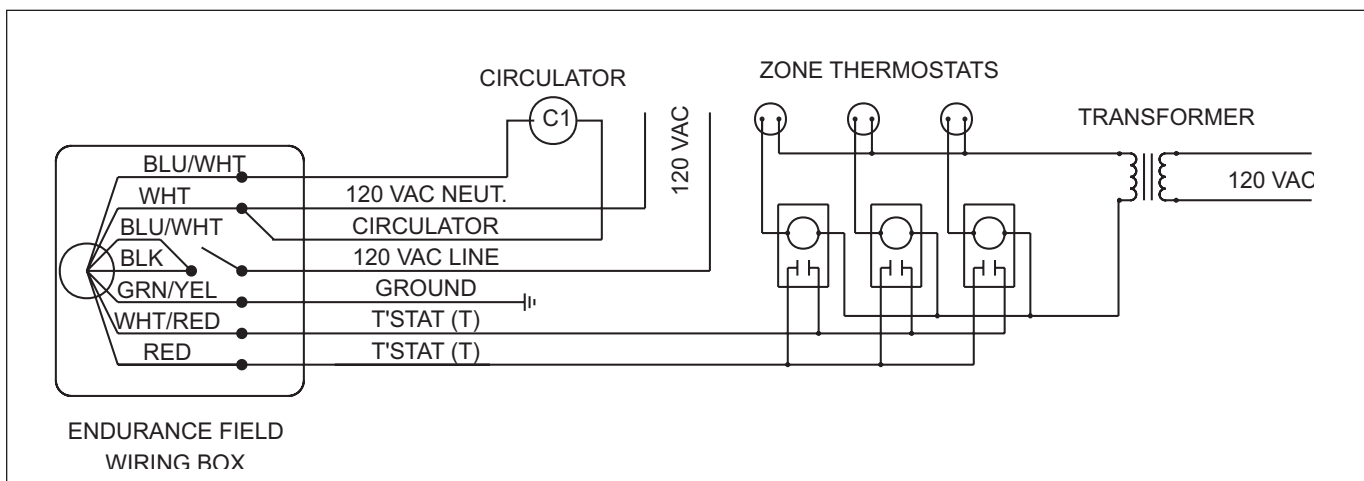

Figure 26. Multiple Zones Utilizing Four Wire Zone Valves with (Dry) End Switches.

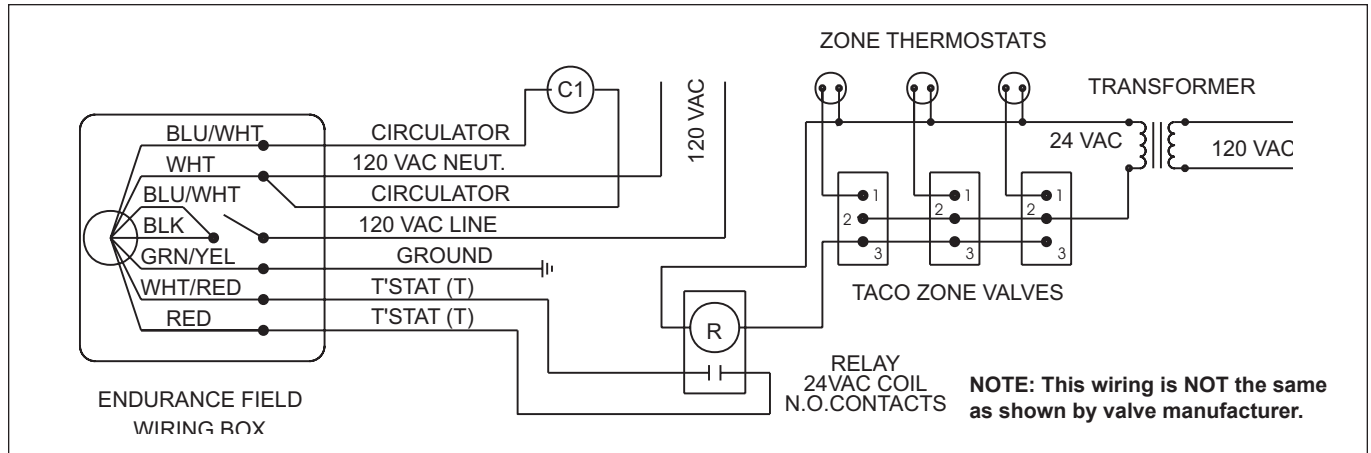

Figure 27. Multiple Zones with Three Wire Zone Valves (Requires Isolation Relay).

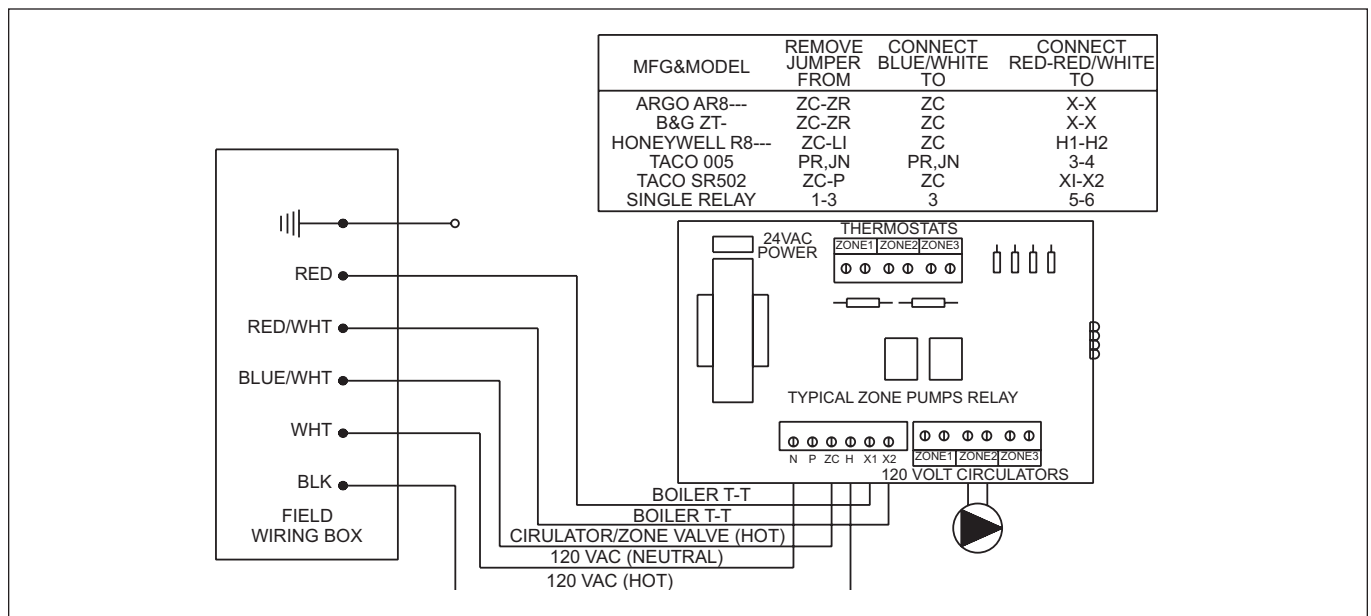

Figure 28. Multiple Zones with Circulators and Room Thermostats.

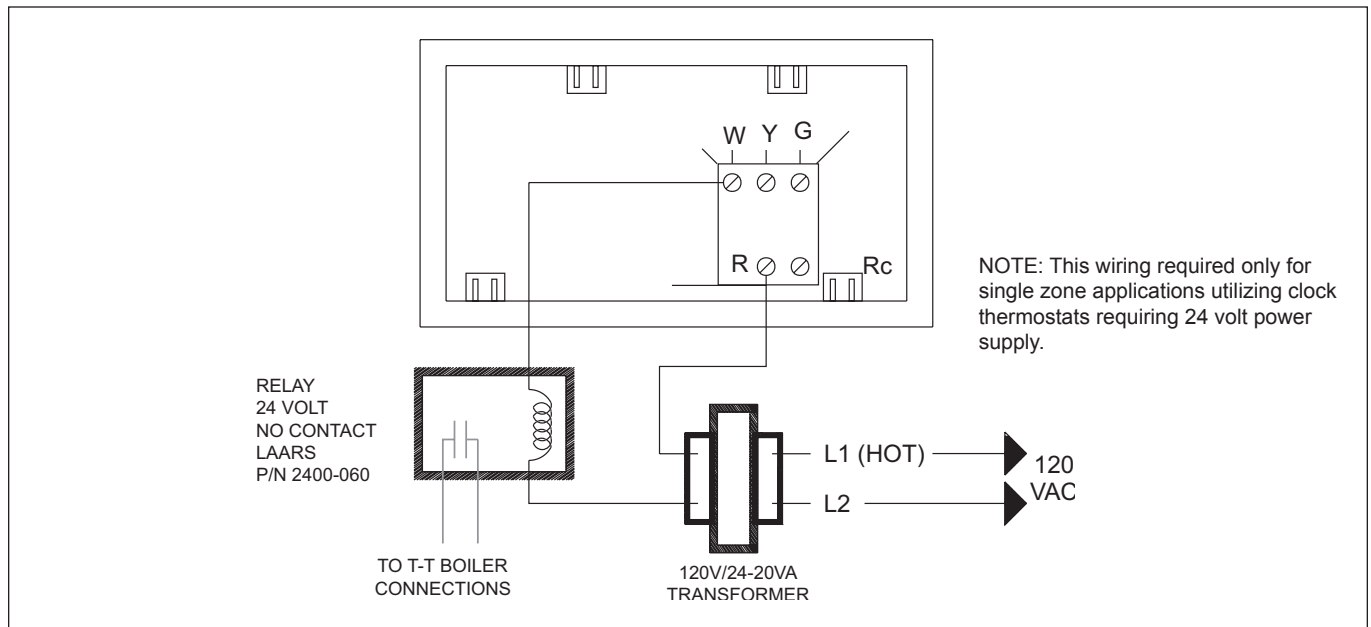

Figure 29. Wiring for Single Zone Power Stealing Type Clock Thermostats That Require 24 VAC.

circulator (120 volt, 5 amp maximum) between the blue wire and the white wire (neutral) (see Figure 26).

- Multi zone/Multi-relay-circulator Installations: Multiple circulators must not exceed 5 amps total when connected to blue wire (see Figure 28).

NOTE: On zone valve systems such as Taco, Automag and others which do not have isolated (dry) contact end switches, a single pole isolating relay must be utilized (see Figure 27).

SECTION 6. Using the Boiler Control

6.1 Front Panel Display

Figure 30 shows the front panel display of the boiler control. The Endurance boiler control has four buttons, which are used to access viewing and programming menus. The LED's at the top of the control show the sequence of events, from left to right: Pump Status, TH Status (boiler attempting to run) and Gas Valve Status.

There are three LEDs that illuminate at the top of the controller, shown as L1, L2 and L3 in Figure 30. These light from left to right, in order of the events that happen when the Endurance receives a call for heat.

L1 (LED on top left of display) lights when the pump is energized.

L2 (LED in the middle top of display) lights when the boiler is attempting to light burner.

L3 (LED on the top right of display) lights when the gas valve is energized.

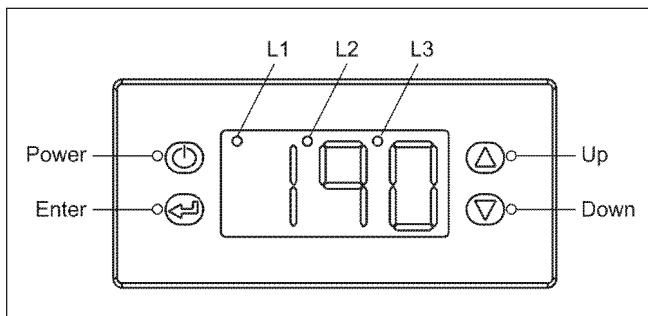

Figure 30. Boiler Control.

6.2 Control Logic

The user sets the Burner Control Point by programming the Burner Off Point. The boiler control modulates the burner to keep the boiler outlet temperature at the boiler control point.

The Burner Off Point minus the Off Point Differential is the Burner Control Point. The Off Point Differential is fixed at 10°F (6°C).

For instance, if the Burner Off Point is chosen as 190°F (88°C), with a fixed 10°F (6°C) differential, the

control will strive to keep the supply temperature at 180°F (82°C).

In this example, when the Endurance gets the initial call for heat, it will start at low fire, and begin its heat-up. The control monitors how quickly the supply temperature is increasing, and bases its modulating rate (output Btu/hr) on that rate of change. The output of the unit will reduce as the water temperature approaches 180°F (80°C). It will attempt to remain at 180°F (80°C) for the entire call for heat. If the system requires less heat than the lowest modulating rate, the outlet water temperature will rise past the Burner Control Point of 180°F (82°C), and will eventually reach the Burner Off Point of 190°F (88°C) and shut off.

The control also has a Burner On Point that is calculated by subtracting the Burner On Differential from the Burner Control Point. The Burner On Differential is adjustable from 4 to 30°F (2 to 17°C) in the EDP/EDN models, and is fixed at 13°F (7°C) on the EBP models (to ensure that the tank will always be charged properly for domestic water calls for heat). In the example here, with a 13°F (7°C) Burner On Differential, that would mean a Burner On Point of 167°F (75°C). During a call for heat, if the Endurance reaches its Burner Off Point, the control will allow the supply temperature to drop to the Burner On Point of 167°F (75°C) before it fires again. Figure 31 shows a graph of this example.

6.3 View Menu

The boiler control allows the user to view the temperatures that are being read by the sensors.

The default display for the boiler control is the supply temperature (defined below). To scroll through and view the other readings, press the up or down button. Figures 32 and 33 show the locations of the temperature sensors in the EBP and EDP/EDN units. Temperatures available in the view menu are:

- Supply Temperature (shown as the default display) — The temperature of the water leaving the boiler heat exchanger.
- Return Temperature (shown as “rtn”) – The temperature of the water entering the boiler heat exchanger. (Note that this is not system return temperature. It is the inlet to the heat exchanger, which is system return mixed with boiler outlet water.)
- Tank Temperature (shown as “tnt”, EBP only) – The temperature of the water in the transfer tank.
- Heat Exchanger Delta T (shown as “dt”) – The temperature difference between the inlet and outlet of the boiler heat exchanger.
- Outdoor Air Temperature (shown as “Oat” when used) – The temperature at the outdoor air sensor.

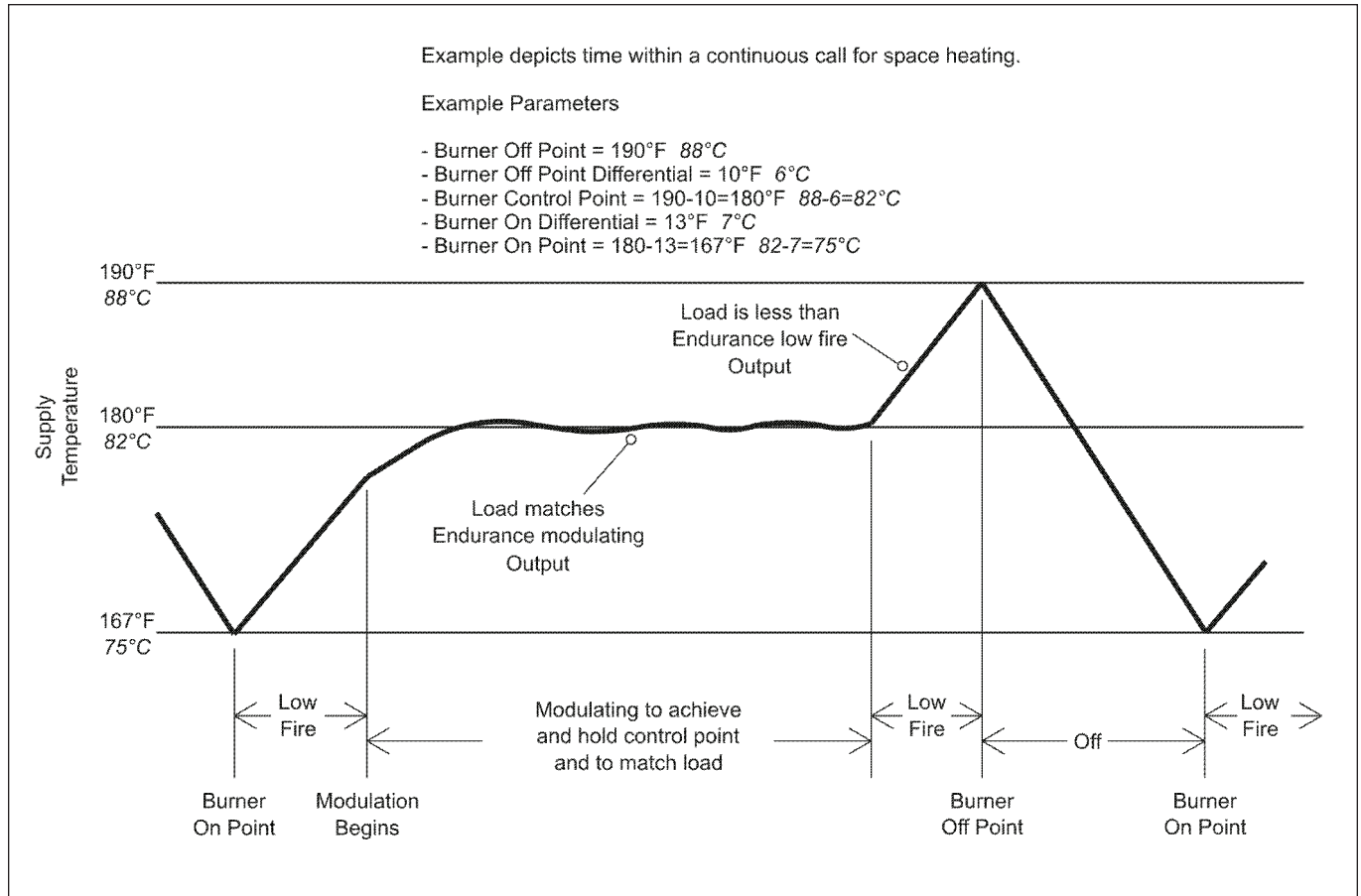

Figure 31. Control Logic Example.

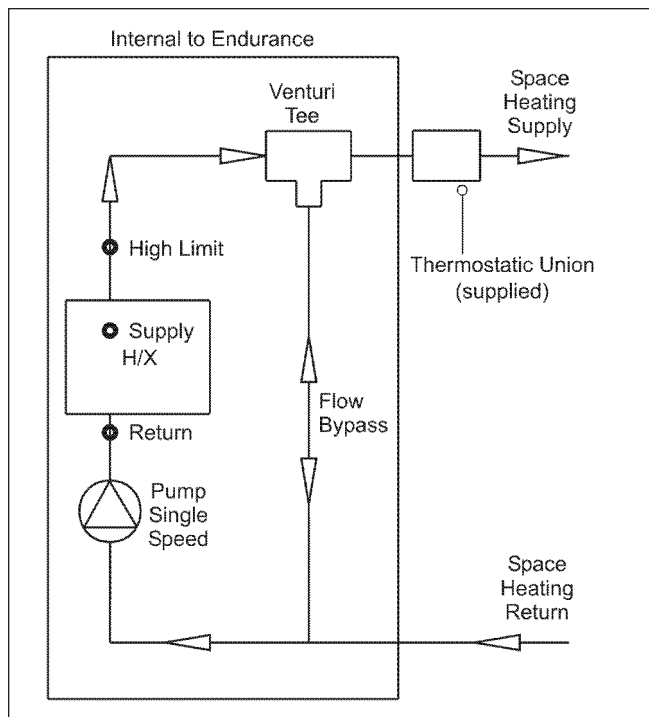

Figure 32. EDP/EDN Flow Schematic.

6. Calculated Setpoint for Outdoor Reset (shown as “CSP” – when used) – The temperature that the controller has calculated for a setpoint, based on the outdoor temperature, when outdoor reset is being used.

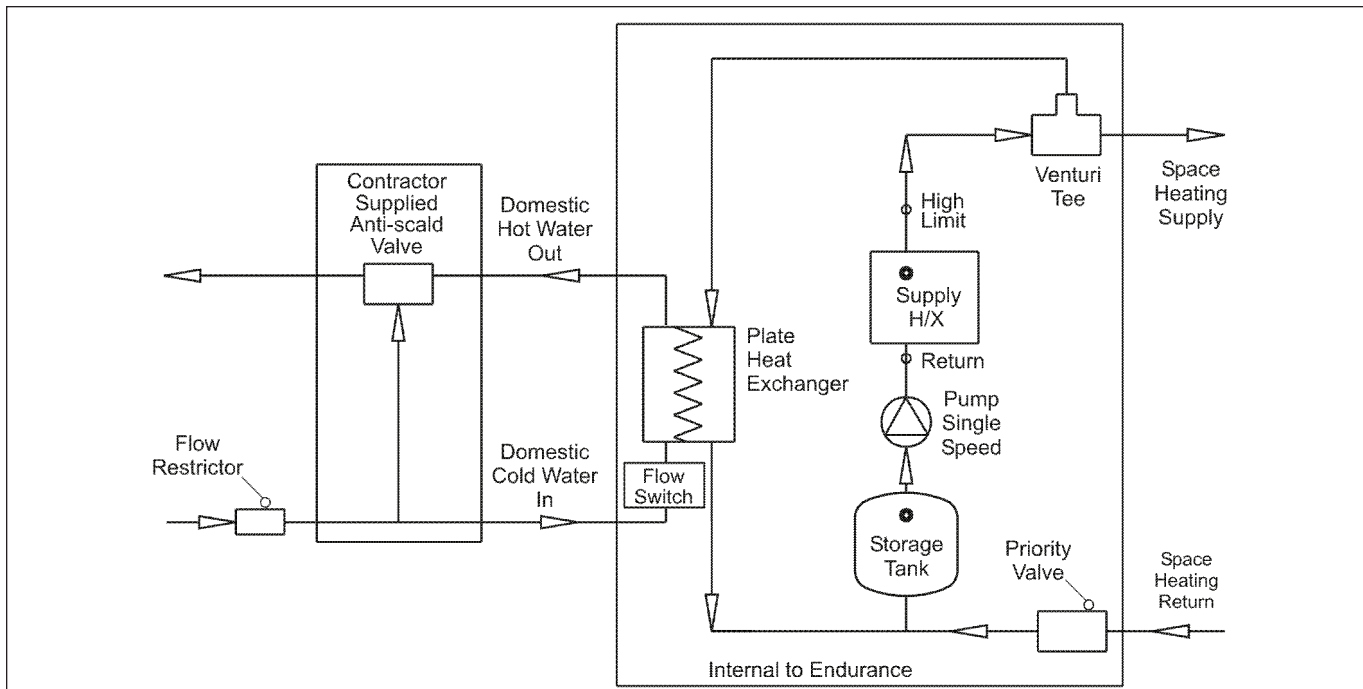

Figure 33. EBP Flow Schematic.

6.4 Setpoint Menu

The setpoint menu is accessed by pressing the enter button, and holding it for 3 seconds. Move through the setpoint parameters by pressing the up and down arrows. When the desired parameter is displayed, press the enter button. Use the up and down arrows to change the value of that parameter, and press enter to save the change. Parameters that can be set on the Endurance boilers are shown in the next sections.

The boiler control will automatically return to the view mode if the control buttons are not pressed for 30 seconds.

6.4.1 “SP” Supply Temperature

Shown as “SP” in the control, the supply temperature is the Burner Off Point. When the temperature of the water that is leaving the boiler heat exchanger reaches this setting, the Endurance shuts off. If there is still a call for heat, it will energize again when it reaches the Burner On Point. Default value is 190°F (88°C). It is adjustable from 170-220°F (77-104°C) on EBP units, and from 155-220°F (68-104°C) on the EDP/EDN units. SP has a fixed 10°F (6°C) differential to the Burner Control Point. SP minus the 10°F (6°C) differential gives you the Burner Control Point, which is the temperature the Endurance will attempt to maintain, using its modulation features. The differential between SP and the Burner On Point is adjustable, using the Burner On Differential.

6.4.2 “PO” Pump Operation

This parameter, shown as “PO” in the selection screen, allows the user to choose between the Endurance pump running continuously (“Con”), or

running in the automatic mode (“Aut”) such that the pump is energized only when there is a call for heat, and has the option of a pump time delay when the call for heat ends.

6.4.3 “Pd” Pump Delay

Pump delay is shown as “Pd” on the screen. When pump operation “PO” parameter is set for automatic (“Aut”), the user can choose the pump delay time. This is the length of time that the Endurance pump will run after the call for heat has ended. It can be used to purge heat from the boiler, putting it into the system or transfer tank. It is adjustable from 0 to 10 minutes, and the default value is 3 minutes.

NOTE: Some systems are designed such that the Endurance pump will be left with only the internal recirculation path when a call for heat has ended. Make sure the system design is known before setting a pump time delay, so that the water has a path during the purge time.

6.4.4 “Oar” Outdoor Reset

Outdoor reset can be turned on and off using the “Oar” parameter. You must have an outdoor sensor, properly located, to use this function.

IMPORTANT NOTE: The Endurance outdoor reset is limited, to ensure that internal water temperature is high enough to prevent heat exchanger condensation. EBP units are limited further, to keep the temperature of the water in the 20 gallon transfer tank high enough to serve the domestic water plate heat exchanger at all times. This feature is not meant to replace or mimic a system outdoor reset controller.

6.4.5 “Oal” Minimum Outdoor Reset Point

The “Oal” parameter tells the controller what the minimum allowable supply temperature can be, regardless of the outdoor reset calculation.

For EDP/EDN units, the default setting is 170°F (77°C) and it is adjustable 155-200°F (68-93°C).

For EBP units, the default setting is 170°F (77°C) and it is adjustable 170-200°F (77-93°C). Note that the difference between EBP and EDP/EDN adjustment ranges is because the EBP units must be able to keep the transfer tank at a high enough temperature to generate the domestic water through the DHW heat exchanger.

6.4.6 “rc” Outdoor Reset Ratio

The outdoor reset ratio is shown as “rc” in the display. The ratio determines part of the relationship between the outdoor temperature and the Endurance supply temperature. It is adjustable between 0.1 and 5. The reset number represents the increase in the Calculated Setpoint (CSP) for every degree below the warm outdoor shutdown temperature.

The boiler control calculates $CSP = Oal + (oTo - air\ temp) \times rc$.

6.4.7 “oTo” Warm Outdoor Shutdown

When in the outdoor reset function is on, the control has the ability to shut down the boiler system when the outdoor temperature sensor reads the “oTo” temperature that is set. This parameter is adjustable from 55°-70°F (13°-21°C) and has a default setting of 65°F (18°C). The warm outdoor shutdown feature will, of course, not affect the generation of domestic water in the EBP models.

6.4.8 “unl” Temperature Units

The control has the ability to display and be programmed in both °F (Fahrenheit) or °C (Celsius). The “unl” lets the user choose between °F and °C.

6.4.9 “Dif” Burner On Differential

The differential between the Burner Control Point and the Burner On Point is shown as “Dif” in the display. If the Endurance reaches the Burner Off Point during a call for heat, and the call for heat continues, this differential will determine at what point below the Burner Control Point the Endurance will energize again. In the EBP models, this differential is fixed at 13°F (7°C) to ensure that the transfer tank will be properly charged. In the EDP/EDN models, this differential is adjustable 4°-30°F (2°-17°C).

6.5 Calculated Control Values

There are several control values that are not directly set by the user, but are calculated by the boiler control, once the user has set the parameters in Section

6.4. These do not show on the control display, but it is helpful to know how they affect the control logic of the Endurance units.

6.5.1 ACV Release (EBP only)

When the EBP is in tank charge mode, and there is a call for space heating, the EBP needs to know at what temperature it can release the ACV (anti-condensing valve) back to the space heating position, allowing the hot water to go into the system. The ACV release point is the “burner off” point minus 5°F (3°C). For example, if the “burner off” point is 190°F (88°C), the ACV release point is 185°F (85°C). This means that when the supply temperature reads 185°F (85°C) in the tank, it will release the ACV for heating mode.

6.5.2 Tank Charge Setting (EBP only)

When the temperature at the tank sensor goes below the tank charge setting, the EBP will be in “tank charge” mode. The tank charge setting equals the programmed “burner off” point minus a fixed 40°F (22°C) differential. For example, if the “burner off” point is 190°F (88°C), the EBP will go into “tank charge” mode when the tank sensor reads below 150°F (66°C). The ACV will close, and the EBP will run to bring the supply temperature up to 185°F (85°C), and the ACV will be released back to the space heating mode (as long as there is no call for domestic hot water).

6.5.3 Burner On Point

The “Burner On” point is calculated by subtracting the “Burner On Differential (Dif)” from the “Burner Control Point.” For EBP units the differential is fixed at 13°F (7°C) and for EDP/EDN units, it is adjustable (shown as “Dif” in the setup menu) from 4°-30°F (2°-17°C). This value tells the Endurance when to re-energize during a call for heat in which the Endurance reached its “Burner Off Point.”

6.5.4 Modulation Point

During a call for heat, the Endurance will ignite at low fire and will begin to modulate to match the load as it approaches the “Burner Control Point.” There is no fixed temperature when this will occur, and this value is not displayed on the Endurance.

6.6 Other Control Functions

6.6.1 Using Buttons on Control

Figure 30 shows a drawing of the control, including the placement of the four buttons. Table 4 shows the actions associated with each of the buttons.

Button	Action	Result
Up Arrow (Upper Right Button)	Press for 1/2 second	1. Scrolls up through view menu 2. In setup menu, scrolls up through setup menu 3. In setup menu, after parameter is chosen, increases the value of that parameter
Down Arrow (Lower Right Button)	Press for 1/2 second	1. Scrolls down through view menu 2. In setup menu, scrolls down through setup menu 3. In setup menu, after parameter is chosen, decreases the value of that parameter
Enter (Lower Left Button)	Press and hold for 3 seconds	Puts the control in setup mode
Enter (Lower Left Button)	Press for 1/2 second	1. When in setup view, chooses the parameter that the user wants to adjust 2. When in setup menu, saves an adjusted parameter
Enter & Up Arrow Together (Lower Left and Upper Right Buttons Together)	Press both together for 2 seconds	High fire hold for 5 minutes
Enter & Down Arrow Together (Lower Left and Lower Right Buttons Together)	Press both together for 2 seconds	Low fire hold for 5 minutes
Power (Upper Left Button)	Press for 1/2 second	When in alarm mode, allows the user to scroll through menu for 30 seconds
Power (Upper Left Button)	Press and hold for 3 seconds	Turns control off or on to allow programming without a call for heat interruption.

Table 4. Boiler Control Button Functions.

6.6.2 Alarm Acknowledge

When an alarm is activated (LO or one of the F codes), the control will flash between the alarm display and the supply temperature. Pressing the power button (upper left button) for half a second will allow the user to scroll through the menus for 30 seconds, before reverting back to the alarm display.

6.6.3 Power On/Off

Pressing the power button on the control (upper left button) for 3 seconds will turn the controller off. This will not de-energize the boiler's power, but will de-energize the controller. The display will still work, but the boiler will not acknowledge a call for heat, and will not be able to fire. This allows the user to check and set parameters when the boiler is unable to fire. The display will show "OFF". When the power button is pressed again for 3 seconds, the display will show "ON" briefly, and the boiler will then resume normal operation.

6.6.4 Low Fire Hold

By pressing and holding the enter button and the down arrow button for 2 seconds, the user will fix the Endurance in low fire for 5 minutes. There is no change in the boiler control display when the unit is in this mode.

6.6.5 High Fire Hold

By pressing and holding the enter button and the up arrow button for 2 seconds, the user will fix the Endurance in high fire for 5 minutes. This can be used

to check and/or set combustion on the appliance. There is no change in the boiler control display when the unit is in this mode.

6.6.6 Pump Operation

The Endurance's internal pump will operate when any of the following conditions occur:

- Low temperature mode.
- Tank charge mode.
- Heating system (T-T) call for heat.
- Domestic hot water (DHW) call for heat.
- Error condition detected.
- Supply temperature detected as less than "boiler on point".

6.6.7 Anti-Condense Valve Operation

The control on the EBP unit opens and closes the Anti-Condensing Valve (ACV) based on the following boiler conditions:

ACV Open:

- Heating system (T-T) call for heat, when there is no tank charge or DHW call for heat.
- Cycles open and then closes every time the EBP is powered up.

ACV Closed:

- Domestic hot water (DHW) call for heat.
- Tank charge mode.
- No heating system (T-T) call for heat.

6.6.8 Field-Supplied Outdoor Reset Controls

When a stand-alone outdoor reset control is used with the Endurance, it will only have the ability to reset the system water temperature, and start/stop a call for heat. Although this will work, be aware that this will likely cut into the modulation range that the boiler control is calculating, because the boiler control is not changing its temperature settings. This may result in an Endurance that works like an on/off boiler, rather than the modulating boiler, and may cycle on and off more frequently than desired.

Endurance units have built-in outdoor reset capability, with the addition of the outdoor reset sensor. This will reset the boiler supply temperature, while ensuring that the temperature is not dropped enough to affect the EBP's domestic water output, and keeping the return temperature to the Endurance high enough to prevent condensation on the heat exchanger.

IMPORTANT NOTE: The Endurance outdoor reset is limited, to ensure that internal water temperature is high enough to prevent heat exchanger condensation. EBP units are limited further, to keep the temperature of the water in the 20 gallon transfer tank high enough to serve the domestic water plate heat exchanger at all times.

SECTION 7. Boiler Start Up

7.1 Removal of Boiler From Common Vent

NOTE: This section does not describe a method for common venting Endurance boilers. It describes what must be done when a unit is removed from a common vent system. Endurance boilers are **not** permitted to be common vented with any other appliance(s), including other Endurance appliances.

At the time of removal of an existing boiler, the following steps shall be followed with each appliance remaining connected to the common venting system placed in operation, while the other appliances remaining connected to the common venting system are not in operation.

1. Seal any unused opening in the common venting system.
2. Visually inspect the venting system for proper size and horizontal pitch and determine there is no blockage or restriction, leakage, corrosion and other deficiencies which could cause an unsafe condition.
3. Insofar as is practical, close all building doors and windows and all doors between the space in which the appliances remaining connected to the

common venting system are located and other spaces of the building. Turn on clothes dryers and any appliance not connected to the common venting system. Turn on any exhaust fans, such as range hoods and bathroom exhausts, so they will operate at maximum speed. Do not operate a summer exhaust fan. Close fireplace dampers.

4. Place in operation the appliance being inspected. Follow the lighting instructions. Adjust thermostat so appliance will operate continuously.
5. Test for spillage at the draft hood relief opening after 5 minutes of main burner operation. Use the flame of a match or candle, or smoke from a cigarette, cigar or pipe.
6. After it has been determined that each appliance remaining connected to the common venting system properly vents, when tested as outlined above, return doors, windows, exhaust fans, fireplace dampers and any other gas burning appliance to their previous conditions of use.
7. Any improper operation of the common venting system should be corrected so the installation conforms with:
 1. The applicable venting requirements of the National Fuel Gas Code (ANSI Z223.1/NFPA 54), latest edition; or
 2. in Canada, The Natural Gas and Propane Installation Code (CSA B149.1), latest edition.

All applicable provisions of local building codes should also be adhered to.

When re-sizing any portion of the common venting system, the common venting system should be re-sized to approach the minimum size as determined using the applicable section of the latest editions of the above-referenced installation codes.

7.1 Enlèvement de la chaudière du système de ventilation commun

REMARQUE : Cette partie ne décrit pas une méthode pour les chaudières Endurance à ventilation commune. Elle décrit ce qui doit être fait lorsqu'une unité est enlevée d'un système de ventilation commun. Il n'est pas autorisé aux chaudières Endurance d'avoir un système de ventilation commun avec tout autre appareils, y compris d'autres appareils Endurance.

Au moment du retrait d'une chaudière existante, les mesures suivantes doivent être prises pour chaque appareil toujours raccordé au système d'évacuation commun et qui fonctionne alors que d'autres appareils toujours raccordés au système d'évacuation ne fonctionnent pas:

1. Sceller toutes les ouvertures non utilisées du système d'évacuation.
2. Inspecter de façon visuelle le système d'évacuation pour déterminer la grosseur

et l'inclinaison horizontale qui conviennent et s'assurer que le système est exempt d'obstruction, d'étranglement, de fuite, de corrosion et autres défaillances qui pourraient présenter des risques.

3. Dans la mesure du possible, fermer toutes les portes et les fenêtres du bâtiment et toutes les portes entre l'espace, où les appareils toujours raccordés et les autres espaces du bâtiment. Mettre en marche les sècheuses, tous les appareils non raccordés au système d'évacuation commun et tous les ventilateurs d'extraction comme les hottes de cuisinière et les ventilateurs des salles de bain. S'assurer que ces ventilateurs fonctionnent à la vitesse maximale. Ne pas faire fonctionner les ventilateurs d'été. Fermer les registres des cheminées.
4. Mettre l'appareil inspecté en marche. Suivre les instructions d'allumage. Régler le thermostat de façon continue.
5. Faire fonctionner le brûleur principal pendant 5 min ensuite déterminer si le coupe-tirage déborde à l'ouverture de décharge. Utiliser la flamme d'une allumette ou d'une chandelle ou la fumée d'une cigarette, d'une cigare ou d'une pipe.
6. Une fois qu'il a été déterminé, selon la méthode indiquée ci-dessus, que chaque appareil raccordé au système d'évacuation est mis à l'air libre de façon adéquate. Remettre les portes et les fenêtres, les ventilateurs, les registres de cheminées et les appareils au gaz à leur position originale.
7. Tout fonctionnement incorrect du système de ventilation commun doit être corrigé, aussi l'installation est conforme aux :
 1. conditions applicables aux systèmes de ventilation du Code américain national sur les gaz combustibles ou *National Fuel Gas Code* (ANSI Z223.1/NFPA 54), dernière édition ou
 2. Code canadien d'installation du propane ou du gaz naturel ou *Natural Gas and Propane Installation Code* (CSA B149.1), dernière édition.

Toutes les clauses applicables aux codes locaux de construction doivent également être respectées.

Lors de la redimensionnement de toute partie du système de ventilation commun, le système de ventilation commun doit être redimensionné pour approcher la taille minimale comme celle déterminée dans la partie en rapport de la plus récente publication des codes d'installation ci-dessus références.

7.2 Filling the System

1. Open all supply and return valves.
2. Fill heating system to minimum operating pressure 12 psig.

3. Loosen screw in coin vent and allow any trapped air to escape. Collect any water that escapes so that it does not drip on the blower electronics and damage them. Small amounts of air that may remain will be purged by the internal pump. Tighten screw after purging.

It is helpful, for air removal, to manually open the lever on the anti-condense valve on the EBP unit. The "manual operation" lever located on the top of the valve operator requires moderate pressure to latch the valve open and then again to unlatch it and allow it to close.

4. Purge all lines by opening vents.
5. Close gas shutoff valve located above gas valve.
6. Turn on 120 volt power, the display will initially display [---] for five seconds before displaying [OFF].
7. If the temperature sensor detects a temperature below 39°F (4°C) it will display [ICE]. The appliance will then be in its Low Temperature Mode. The Endurance will call for the pump to run for 5 minutes, or until the discharge temperature reaches 45°F (7°C). (EBP ONLY: When the internal zone valve is manually opened, the water will be allowed to be pumped to the space heating system, if the system zones are also open. This is a good time to ensure that the system is fully discharged of all air and the water charge pressure is correct.)
8. If the display remains at [OFF], press the on/off button on the boiler control. The Endurance will respond to any calls for heat it has (DHW, tank charge, or space heating). The appliance will attempt to ignite three times after which it will lock out and display [LO]. The fan and the pump will then stop. Ensure that the system is fully discharged of all air and the water charge pressure is correct.
9. Turn the main electrical supply off.
10. **EBP ONLY: Manually reset the internal zone valve to its normal position.**
11. System is now ready for operation.

7.3 Firing Burner

1. Be sure the system has been filled properly and is leak tight.
2. Open gas shutoff valve.
3. Turn on main electrical switch.
4. If the temperature sensor detects a temperature below 39°F (4°C) it will display [ICE]. The appliance will then be in its Low Temperature Mode.
5. If the display shows "OFF", press the on/off button on the front upper left of the boiler control.
6. If the boiler had been locked out, the reset button on top of the Endurance will need to be pressed.

7. When there is a call for heat, the pump and the blower will start, the display will show the supply temperature. The appliance will attempt to ignite three times, if ignition is not successful, the appliance will lock out and display “LO”. Ignition reset is done by pressing the reset button on top of the control panel. EBP models will continue to operate until the 20 gallon transfer tank is up to temperature.
8. EBP only: Turn on a hot water tap. This puts the appliance in the DHW mode.

Caution

Should any pronounced odor of gas be detected, or if the gas burner does not appear to be functioning in a normal manner, close main shutoff valve, do not shut off switch, and contact your heating contractor, gas company, or factory representative.

You **MUST** check flame monitoring control (ignition system safety shut-off device).

9. Close gas shutoff valve with burner operating.
10. The gas valve status light will go out, and immediately a new trial for ignition will begin. The burner will not relight, because the gas is off. The control will make two more attempts to light the burner. Ignition will not occur, as the gas is off. The boiler will lockout, and the display will show “LO” after the gas valve has closed on the third ignition attempt. The ignition control LED will show a three-flash sequence.
11. Open gas shutoff valve. Press reset button on the top of the control panel. The ignition sequence will start again and the burner will start. The appliance will return to its previous mode of operation.

SECTION 8. Maintenance and Component Description

Figure 34 shows the location of the control panel components. The parts sections show the other components on the Endurance.

8.1 Unit Pump

The unit pump operates whenever there is a call for heat or hot water.

It is a wetted-rotor type pump and should always be filled with water when it is operating so that it will cool properly.

If a pump change is required for any reason, valve off the boiler and drain approximately 1 or 2

gallons (approx. 4-8L) of water from it. Turn off the main disconnect switch and unplug the pump wires, remove the pump motor. The pump housing need not be removed. The replacement pump motor should be installed in the reverse order from which the old pump motor was removed. After filling the system be sure the combustion chamber coil vents through the air vent located on top of the boiler chamber (inlet manifold extension).

8.2 Gas Valve

The gas valve is a 24VDC solenoid operated, negative pressure regulated ratio valve. The outlet pressure may be adjusted as described in the service section. It is designed to operate with supply pressures of 4-13 inches w.c. (1.0 to 3.2 kPa). To remove the gas valve, shut off 120 volt power and the gas shutoff valve, remove the 4 screws on the upper and lower flanges and disconnect the wires from the gas valve, the valve may now be removed. After the valve has been removed, replace with a new valve in the reverse order in which the old valve was removed. Turn on gas shutoff valve and 120 volt power and check boiler operation and gas tightness of gas valve connections.

8.3 Safety Limit Switch

The Safety Limit Switch is an automatic reset switch with a fixed set point of 230°F (110°C). To replace the switch, shut off the 120 volt power. Disconnect the 2 wires from the quick connects at the switch and remove the switch. To replace, perform the same operations in reverse. Turn on disconnect switch and check boiler.

8.4 Boiler Control

The Endurances uses an FX05 boiler control. The control takes inputs from a domestic hot water flow switch, an overheat thermostat (safety high limit), external space heating switch, and temperature sensors throughout the Endurance unit. Using these signals, it works with the ignition control to ensure proper and safe operation of the Endurance. It controls call for heat, the modulating point for the blower, the Endurance pump, and the signals that are sent to the ignition control.

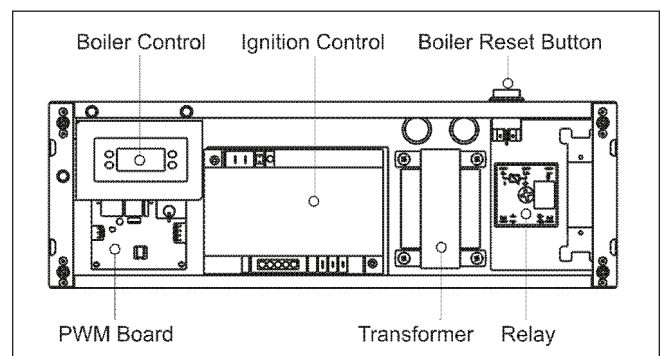

Figure 34. Control Panel.

The control displays the supply temperature, by default, and the user can access the heat exchanger inlet temperature, tank temperature (EBP models), heat exchanger delta T, outdoor air temperature (if reset is used), and all of the setpoint and differentials that are set on the boiler. 7 fault codes can also be displayed, for diagnostic help.

To replace the boiler control, shut off 120V power to the Endurance. Remove the two sheet metal screws from the controller mounting bracket. Pull the controller, attached to the mounting bracket out, to access the electrical connectors.

Remove the electrical connectors from the control. Pull out the tabs on the retaining clip, while pulling the controller out through the front.

Replace in reverse order.

8.5 Ignition Control

The ignition control controls the hot surface ignitor and proves that the flame signal is appropriate for powering the gas valve. It also controls the blower's pre-purge and post-purge timing. It works with the boiler control to ensure proper and safe operation of the Endurance.

To replace the ignition control, shut off the 120-volt power to the appliance. Remove the cover to the Endurance control panel. Remove the electrical connectors from the ignition control. Take out the controller's mounting screws, and pull the controller out. Replace in reverse order.

8.6 Ignitor / Flame Sensor Assembly

The ignitor is a hot surface ceramic composite device. It is energized whenever there is a call for heat and switched off when ignition is established.

The flame sensor is a remote sensing flame rod which is connected directly to the ignition control. The ignitor should read 50 to 100 ohms resistance when at room temperature.

If the ignitor fails and the assembly must be replaced, always install a new ignitor gasket with the replacement assembly.

For sequence of operation, see Section 9.1, Servicing.



8.7 Transformer

The control transformer accepts 120 VAC line voltage and provides 100 VA of 24 VAC control voltage for the boiler control ONLY. It is NOT capable of supplying control voltage for external devices such as zone valves, which MUST have their own separate power supply.

Should the transformer require replacing, shut off the 120 volt power. Unplug the transformer wires from

the transformer, unscrew the two fixing screws and remove the transformer.

Fit the replacement transformer in reverse order.

8.8 PWM Board

The PWM board converts the 0-10V modulating signal that comes from the boiler control to the PWM (pulse width modulating) signal that is sent to the blower to control the blower speed, and hence, the modulating point of the Endurance.

This board also converts 24V AC to 24V DC, which is used to power the boiler.

To replace the PWM board, shut off the 120 volt power. Unplug the two electrical connectors to the PWM board. Depress the barbs on the four standoffs to free the board, and pull it out. Replace in reverse order.

8.9 Blower

The combustion air blower is a high pressure centrifugal blower. It is powered by a 24VDC motor which is controlled by the boiler control with voltage that has been converted by the PWM board. Its speed will be varied according to the temperature of the boiler flow.

If a blower change is required, turn off the 120 volt power and unplug the wires from the blower motor. Remove the four nuts from the blower discharge flange and the four screws that secure the gas manifold to the gas valve. Remove the complete assembly. Unscrew the combustion air inlet assembly and register plate from the fan.

Fit the replacement fan in reverse order, ensuring that all joints are made correctly and sealed.

After replacement the combustion should be checked for correct air fuel ratio (see Section 10).

8.10 Transfer Tank (EBP)

The transfer tank contains approximately 20 gallons of boiler water. It functions as an energy storage vessel to reduce boiler cycling on small output heating zones and to provide additional heat for domestic hot water through the domestic hot water (DHW) plate heat exchanger.

If a tank change is necessary, access to the tank is possible by removing the jacket's front door. This is done by removing the screws that hold the panel at the top and lifting the panel away. Isolate the appliance and drain down using the drain cock at the base of the tank. Remove the tank sensor. Undo the union and the pump flange bolts that connect the tank to the boiler, unscrew the panel between the upper and lower compartments, support the upper components and remove the tank. Installation of the new tank is done in the reverse order. After installation purge all air from the boiler before restarting.

8.11 Thermostatic Union (EDP/EDN)

The thermostatic union is a 1¼" NPTF union which must be mounted at the flow outlet to control boiler temperature. The union must be installed so that union nut is on the boiler side of the connection. This insures that the thermostat is properly positioned with its spring facing up, toward the system. The element has small bypass holes that allow some water to flow into the system at all times. When the boiler first starts and the element is closed, boiler water is re-circulated back to the return until the supply water reaches 160°F (71°C). The element then modulates open. If the temperature does not exceed 150°F (66°C) within two minutes after firing, the element is not functioning properly. To replace the element, shut off and drain the section of the system adjacent to the thermostatic union. Open the union and replace the element with a new one. The element should be installed so that its spring and actuator are facing the system side (up). Close the union, open the valves, refill and bleed the system. Ensure that air is venting from the air vent on top of the boiler chamber and it is left operational. Restart boiler.

8.12 Cleaning the Boiler Coil

The Endurance is equipped with a premixed combustion system. This type of combustion system does not create free carbon (soot) except in very rare instances and therefore the combustion chamber coil will probably never need cleaning. If cleaning is required, proceed as follows: valve off the boiler, switch off the electrical power at the disconnect switch, drain 1-2 gallons (4-8L) of water from the boiler drain, remove the flue assembly from the top of the boiler, remove the pump flange bolts from the top pump flange, disconnect the sensor wires from the sensors (boiler flow, return and safety limit), undo the

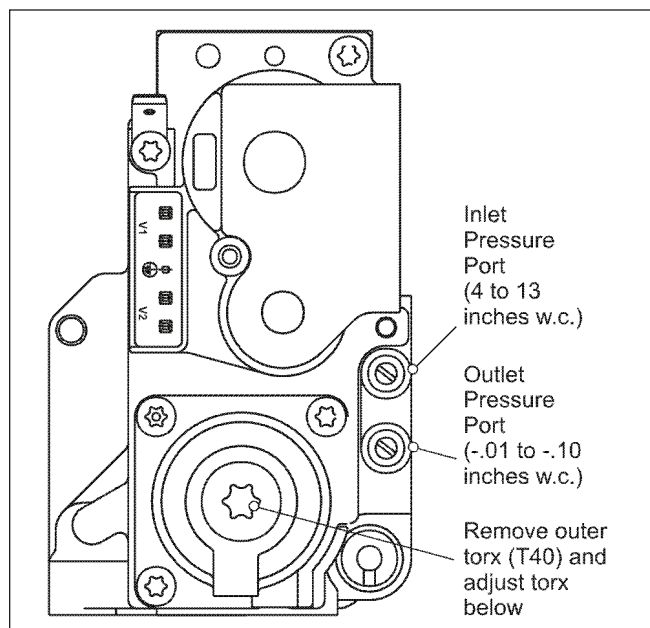

Figure 35. Gas Valve.

union nut from the boiler flow manifold, and remove the four (4) screws from the bottom gas valve flange. Unplug the blower and the ignitor. Remove the bolts from the blower and pull the blower out. The boiler assembly may now be removed from the jacket. After removal of the boiler assembly from the jacket, remove the ignitor and the burner from the combustion chamber. Then, remove the four (4) long screws that secure the top and bottom pans. Remove the air vent and the top pan. Remove the insulation retainer and the coil cover insulation. Clean the boiler coil with a wire brush and vacuum debris from the combustion chamber (avoid hitting the ignitor or the flame sensor with the brush or vacuum hose because they are fragile).

After cleaning, assemble the parts in the reverse order, open isolation valves and bleed air from the boiler and the system. Follow the lighting instructions and start the boiler. Check operation.

SECTION 9 Servicing.

9.1 Sequence of Operation

Figures 32 and 33 depict the flow paths and temperature sensor locations for the space heating, EDP/EDN, and the combined space heating and domestic water heating, EBP, appliances.

The model EDP/EDN modulating boilers are cold start boilers that will start only on a call for heat from a room thermostat or zone control contact.

During normal operation the boiler control will display the supply temperature. The Endurance call for heat may come from any of the following:

1. Heating call for heat (TT) from thermostat, end switch, etc.
2. Domestic water call for heat from domestic water flow switch (EBP only).
3. Tank charge call for heat, when transfer tank is less than 40°F (22°C) below the Off Point (EBP only).

On a call for heat the following sequence will occur.

1. For EBP units only, the anti-condensing valve is put in the proper position.
2. The internal pump starts.
3. Blower pre-purge begins (7-seconds).
4. Boiler control sends the signal to the ignition control that there is a call for heat.
5. After a self-check and 15 second ignition control "pre-purge", the ignition control begins the ignitor warm-up period.
6. After the ignitor is warmed up, the gas valve terminal on the ignition control is energized for the 10-second trial for ignition.

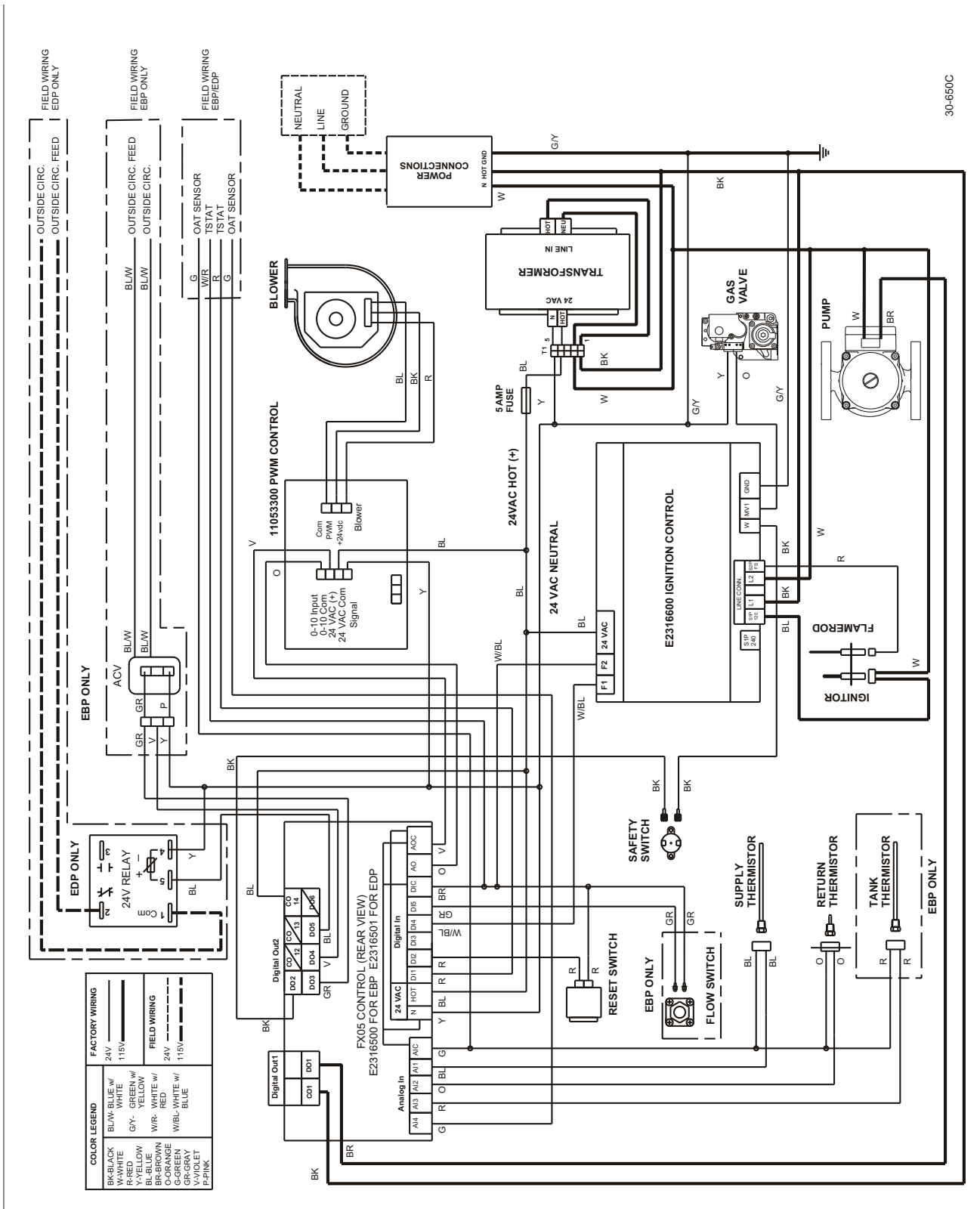

30-650C

Caution
Label all wires prior to disconnection when servicing controls. Wiring errors can cause improper and dangerous operation. Verify proper operation after

ATTENTION
Au moment de l'entretien des commandes, étiquetez tous les fils avant de les débrancher. Les erreurs de câblage peuvent nuire au bon fonctionnement et être dangereuses. S'assurer que l'appareil fonctionne adéquatement une fois

Figure 36. EDP/EDN Wiring Diagram.

7. 10 seconds after establishing combustion and proof of flame (via the flame rod signal to ground), the ignitor will be de-energized.
8. For EDP/EDN units only, the display should indicate a rapid rise in temperature to 150° F (1-2 min. duration). During this period the thermostatic union at the flow outlet is closed and the boiler is operating in the internal recirculation mode. [Service note: If the temperature rise is not rapid the thermostat may be defective.] At 150° F the thermostat will allow increased flow to the system.
9. A gradual rise in temperature will be indicated until the temperature approaches the Burner Control Point. The firing rate will modulate based on the rate of change in temperature as it seeks the control point.
10. If, during a call for heat, the temperature reaches the Burner Off Point, the Endurance combustion will be de-energized, and will allow the temperature to fall to the Burner On Point before turning on again.
11. When the call for heat ends on an EDP or EDN model, the gas valve shuts off, and the pump post-purge begins, if activated. When the call for heat ends on an EBP model, the anti-condensing valve closes, and the Endurance goes into tank charge mode, until the burner off point temperature is achieved on the supply sensor.

9.2.1 Fault Code Identification

The boiler control can display the following fault codes:

- F1 = Boiler control internal error
- F3 = Gas valve status is on, with no call for heat
- F4 = Supply sensor error
- F5 = Tank sensor error (EBP only)
- F6 = Return sensor error
- F8 = OAT sensor unreliable
- LO = Lockout
- OFF = Controller is off
- ICE = Low temperature protection

The boiler shows an alarm condition by flashing the code and then showing the supply temperature. All of the fault conditions shown on the boiler control will prevent the Endurance from operating, with the exception of F8. If the outside air temperature sensor is found by the controller to be unreliable, the controller will override the outdoor reset function, and will run the Endurance in setpoint mode, instead of outdoor reset mode.

The ignition control uses LED indication to display the following fault codes:

- Steady On = Internal control failure
- 2 Flashes = Erroneous flame signal
- 3 Flashes = Ignition Control Lockout

9.2.2 Fault Correction

- F-1 Switch off boiler and restart. If F-1 repeats, replace boiler control.
- F-3 In normal operation, the ignition control sends a “gas valve energized” signal to the boiler control, so the controller will be able to time its PI algorithms correctly. An F-3 fault code indicates that the ignition control is sending a signal that the gas valve has been energized, but there is no call for heat. The boiler control will not allow the Endurance to fire in this condition. This fault indicates that there is either something mis-wired on the boiler, or that the relay in this circuit has seized. Check the relay for seized contacts first, and if the relay is operational, check the wiring circuit on the boiler.
- F-4 Check for damaged wiring or poor connection at sensor plug. If they are OK disconnect the sensor plug and check the resistance across the sensor terminals. The resistance of a good sensor is 10,000 ohms @ 77°F (25°C). Replace sensor if resistance is less than 500 or more than 20,000 ohms.
- F-5 Correct in the same manner as F-4.
- F-6 Correct in the same manner as F-4.
- F-8 Check that the outdoor air sensor is installed properly, and that the wire and/or connection are not damaged. If okay, disconnect the sensor and check the resistance across the sensor terminals. The resistance of a good sensor is 10,035 ohms at 77°F (25°C). Replace sensor if resistance is less than 500 or more than 20,000 ohms.
- LO See Section 9.2.3
- OFF Control power is off. Press and hold the power button (upper left button) on the boiler control for 3 seconds to restore control power. The control will flash “ON” and then will return to normal operation.

9.2.3 Resolving Lockouts (LO)

There are many causes for lockouts. The six most common causes are: (a) poor combustion, (b) poor flame sensor signal, (c) inadequate gas supply, (d) ignitor failure, (e) blocked or contaminated air source, (f) safety limit trip. If you get LO on boiler control, you need to check the ignition control to see if

it is flashing three times, for ignition control lockout. If it is, then that is a combustion lockout.

- a. **Poor Combustion:** Poor combustion should be suspected if there is a strong flue gas odor. The odor may result from either an improper gas/air ration (high or low CO₂) or contamination of the combustion air supply. If an improper gas/air ratio is suspected refer to “gas valve calibration (offset adjustment)” in Section 10. If contamination of the air source is suspected, check the vent system for leaks back into the combustion air.
- b. **Poor flame sensor signal:** The boiler control board will lockout if the flame sensor is grounded or if the flame signal it receives is less than 1 μ A dc. To check for a grounded sensor, remove the flame sensor wire (yellow) from the boiler control board and check for continuity between the yellow wire terminal and the combustion chamber bottom pan. If there is continuity, the flame sensor is grounded. An alternate way to check for grounding of the flame sensor is to check the ohms resistance between the yellow wire terminal and the combustion chamber bottom pan, using a meter set for at least 100,000 ohms. The resistance must be more than 250,000 ohms (some technicians have been confused by meters which report infinite resistance with what appears to them as double zeros; an infinite resistance reading means there is no grounding of the flame sensor.) If there is continuity, or the ohms resistance is less than 250,000 ohms, debris or moisture in the combustion chamber may be the cause. To correct, carefully remove the ignitor and flame sensor assembly. Look for debris on the assembly where the flame rod exits the ceramic tube. If debris exists, remove it. If this area is clean, insert a pencil or other round object into the flame sensor hole in the bottom combustion chamber pan and roll it around to clear any debris that may exist inside the combustion chamber. Replace the ignitor/flame sensor assembly, reconnect the yellow wire and start the boiler. If lockout persists, check the flame signal. The minimum flame current necessary to keep the system from lockout is 1 microamp (μ A). **There is no need to disconnect anything to measure the flame current signal.** To measure the flame signal, connect an analog DC microammeter to the FC terminals on the ignition control, per Figure 37. The meter should read 1 μ A or higher. (If the meter reads below “0” on the scale, the meter leads are reversed. Disconnect and reconnect the meter for correct polarity.) If the meter reading is less than 1 μ A, see the “poor combustion” section. (Check for air leaks at inlet to blower.)

- c. **Inadequate gas supply:** Before proceeding, ensure that the gas supply has not been shutoff or the LP tank (LP boilers) is not empty. Then, reset the boiler and observe the operational cycle. Approximately 20 seconds after the start of the cycle, the GV LED on the boiler control should light. If it does not, reset the boiler and check for 24 VAC at the boiler control. If the voltage is less than 20 VAC, and transformer voltage is 24 VAC replace the boiler control. If the voltage is correct, connect a pressure gauge to the offset pressure port on the gas valve. Reset the boiler and observe the offset pressure at startup and after 20 seconds. The pressure will be \sim -2 in. w.c. at startup (during prepurge) and should become less negative (-0.1 in. w.c.) when the gas valve opens and gas flow starts. If the pressure remains at \sim -2 in. w.c. throughout the cycle replace the gas valve.
- d. **Ignitor failure:** If the boiler goes through a normal start cycle but combustion does not occur, ignitor failure should be suspected. Check the ignitor by unplugging the ignitor plug and measuring the ignitor resistance. It should be 50-100 (Ω) ohms. If the resistance is not 50-100 ohms (Ω), replace the ignitor. If the resistance is correct, reset the boiler and check for 120 VAC at the ignitor plug during the start cycle. If there is no voltage, replace the boiler control or faulty ignitor wires.
- e. **Blocked or contaminated air source:** Before proceeding, ensure that the vent terminal (Direct Vent installations) or the air inlet (Category IV installations) is not obstructed. In general, only direct vent installations have the potential for cross contamination (flue products entering the combustion air stream) of the combustion air source. This may be caused by leaky joints in the 3" flue pipe located inside the 5" combustion air pipe. If this is suspected, remove the front panel from the appliance, reset the boiler and allow it

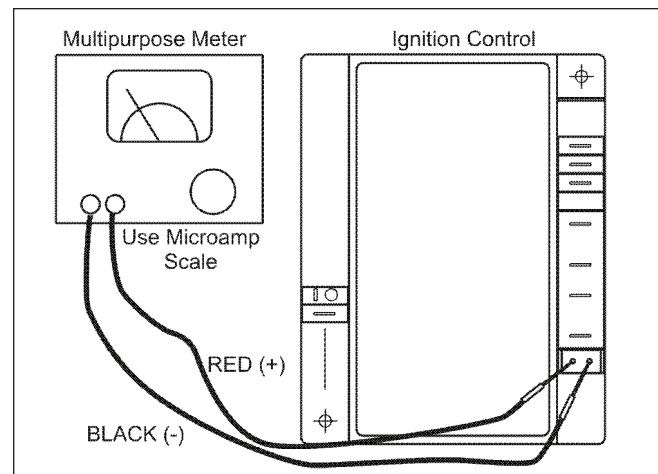

Figure 37. Flame Sensor Current Check.

to go through a normal cycle. If during this cycle there is no flue odor, repair the leaky joints in the flue pipe.

- f. Safety limit trip: The safety limit on the Endurance is interlocked with the boiler control. If this limit detects outlet water temperature greater than 230°F (110°C), or if there is a component failure, the limit will open the boiler circuit and the boiler control will indicate LO on the display. The safety limit will automatically reset when the water temperature drops. If the temperature has exceeded 230°F (110°C), determine the cause of the high water temperature and correct. If the switch is tripped when the water has not reached 230°F (110°C), replace the switch.

SECTION 10. Air Orifice and Gas Valve Adjustment

If poor combustion is suspected because of a strong exhaust smell, pulsation in the exhaust, or nuisance flame failure lockouts (shown as “LO” on LED), the air orifice may need to be adjusted.

Note: Direct vent installations may experience poor combustion that results from cross contamination of the combustion air source. Check for cross contamination before attempting offset pressure adjustment (see Section 9.2.3 step 5).

To adjust the air orifice, remove the door panel, and remove the plug in the flue stack. Perform a CO₂ analysis while the boiler is running at the maximum firing rate. (Pressing the enter button and the up arrow on the boiler control, and holding them for 2 seconds, places the Endurance in high fire for 5 minutes).

Natural Gas:

- If CO₂ is greater than 9.6, open the holes on the adjustable inlet. Adjust the cover until CO₂ is within the range listed in table 5.
- If CO₂ is less than 9.0, close off the adjustable inlet. Adjust the cover until CO₂ is within the range listed in table 5.

LP Gas:

- If CO₂ is greater than 10.1, open the holes on the adjustable inlet. Adjust the cover until CO₂ is within the range listed in table 5.
- If CO₂ is less than 9.7, close off the adjustable inlet. Adjust the cover until CO₂ is within the range listed in table 5.

Reinstall the flue stack plug when finished testing.

If CO₂ is still out of range, adjust the gas valve calibration. (Always adjust the air orifice first.)

To adjust the gas valve calibration, see figure 35 for the location of the offset pressure port and the offset adjustment. When adjusting the offset pressure, the CO₂ will reduce as the offset pressure is adjusted more negative. Adjust the offset pressure to achieve the values shown in Table 5. Note that during the pre-purge cycle, the gauge will indicate several inches w.c. negative pressure.

Always check the CO₂ after making adjustment to the gas valve.

IMPORTANT NOTE: FINAL ADJUSTMENT OF THE OFFSET PRESSURE MUST ALWAYS RESULT IN A NEGATIVE PRESSURE UPON COMPLETION.

	Natural Gas	LP Gas
CO ₂	9.0 to 9.6 %	9.7 to 10.1 %
O ₂	4.5 to 5.0%	4.5 to 5.0%
Offset	-0.01 to -0.10 in. w.c.	-0.01 to -0.10 in. w.c.

Table 5. Combustion Parameters.

SECTION 11. Symptom Evaluations

11.1 Delayed ignition

Possible Causes

- High lockup pressure (LP boilers) - occurs on start-up.
- Gas valve regulation problem - occurs on start-up.
- Incorrect gas orifice (Natural gas orifice in an LP boiler) - occurs on start up
- Defective burner - occurs on startup or at burner shutdown.

High lock up pressure is the most common cause of delayed ignitions on LP fueled boilers. It may result from an improper second stage regulator selection or from a faulty regulator.

Lock up can be detected by measuring the gas supply pressure to the boiler at the inlet pressure tap on the gas valve. The gas supply to the boiler must be shut off before making this connection. Use a water manometer or pressure gauge with a scale reading of at least 25 in. w. c. or 15 oz/in². Loosen the screw in the gas valve pressure port one full turn and install a hose from the pressure gauge over the pressure port. Turn on the gas supply. The ENDURANCE boiler is designed to operate with supply pressures of 4-13 in. w. c. (2.3 - 7.5 oz/ in²). If the supply pressure exceeds 13 in. w. c. (7.5 oz/ in²) with the boiler not operating it is possible that this may be the cause of delayed ignitions and the pressure must be reset to ~ 9 in. w. c. (5.2 oz/ in²). Restart the boiler and then switch it off again. Lock up pressures must be measured when the boiler is not operating and preferably immediately after boiler shutdown. If the gas pressure again exceeds the allowable values, correct the lock up problem.

Gas valve regulation problems can also cause delayed ignitions. See “Gas valve calibration”.

Incorrect gas orifice – Check orifice size.

A defective burner can cause a delayed ignition during operation or at shutdown. If the gas supply pressure is proper the gas valve is functioning properly and the gas orifice is correct, the burner should be inspected. To inspect it, remove the blower. The burner is retained by the blower and it will drop out of the bottom of the chamber when the blower is removed. There should be no distortion or perforations in the burner other than the punched holes. Replace if indicated.

11.2 Short Cycling

Possible causes

- a. Reduced system flow - EDP
- b. Thermostatic union (EDP) or anti-condensing valve not opening (EBP).
- c. T-T wires cross connected (jumped) – **improper installation** - EBP or EDP/EDN
- d. Leakage of flue products into the combustion air stream – Direct Vent Installations only, see Section 9.2.3, Resolving Lockouts.

11.3 Noisy Operation

There are two principal sources of noisy operation:

- a. Combustion - high pitched noise - whistle or hoot.
- b. Boiling (kettling) - lower frequency noise which varies with temperature - moan.

Many times it is difficult to determine the source of the noise or if it is combustion related or boiling related. Combustion noises always have the same frequency; however, their volume may change from the time that the burner first fires to the time that it shuts off. A boiling noise is identified by rapidly raising or lowering the system water pressure while the noise is present. A change in the pitch or intensity of the noise indicates a boiling problem.

Combustion noise occurs at any boiler discharge temperature and is heard the loudest at the flue outlet (especially on units that are sidewall vented). There are two basic causes for the noise, rich mixture (high CO₂ or low O₂) or cross contamination. The mixture is determined by measuring the percent O₂ or CO₂ in the flue products. O₂ readings lower than 4½ % or CO₂ readings higher than 9¼ % (natural gas) and 10.8% (LP) will often cause combustion related noise. The rich mixture could be caused by the mis-calibration of the gas valve (offset adjustment) or by the gas orifice size. To eliminate the noise; first, check the gas valve calibration. If it is correct, install a smaller gas orifice so that the O₂ will rise above 4½% or the CO₂ will drop to 8½% (natural) or 9½% (LP).

The CO₂ & O₂ readings may be influenced by cross contamination. Suspect cross contamination if the noise returns when the front panel is replaced.

Boiling (kettling) may occur at boiler discharge temperatures from 170°F to 210°F. The temperature at which it starts will vary from one installation to another. The primary cause of the problem is poor heat transfer on the inside of the boiler coil. This may be caused by foaming due to excessive concentration of antifreeze in the system or by scaling from the boiler water due to hardness of make up water.

Plumbing antifreezes should never be used in a boiler system. Only boiler antifreezes, with effective antifoamants, are appropriate for the ENDURANCE boilers.

NOTE: The concentration of appropriate antifreeze should be always be kept as low as possible to minimize its effect on heat transfer and efficiency.

The method for eliminating the boiling noise is the same regardless of the cause. However, if antifreeze in the system is suspected of being the cause, the concentration (<35%) and type should be investigated.

Moisture

Although it is not a primary cause of lockouts, moisture in the combustion chamber may cause lockouts by weakening the flame signal to the boiler control. It should be suspected if the boiler temperature does not rise above 160°F during long periods of operation. This condition can be caused by a defective thermostat in the thermostatic union of EDN or EDP boilers (or the omission of the thermostatic union at installation) or failure of the anticondensing valve in the EBP (combi) boilers. Moisture can also get into the combustion chamber through an incorrectly pitched or incorrectly installed flue pipe (pitched back toward the boiler without a condensate trap). The flue assembly of EBP, EDN and EDP boilers installed as Direct Vent boilers should always pitch down from the boiler.

11.4 Insufficient Hot Water (EBP only)

Possible cause:

- a. No flow restrictor (supplied with unit - field installed)
- b. Water flow switch failure
- c. Mixing valve setting or failure
- d. Domestic hot water (DHW) heat exchanger contamination

The most common cause for insufficient hot water complaints results from failure to install a flow restrictor. The absence of a flow restrictor allows water to pass through the heat exchanger at a greater rate than the boiler output is capable of heating to the desired temperature.

Failure of the water flow switch to operate during a hot water draw prevents boiler water from flowing through the DHW heat exchanger and therefore the DHW will not be heated.

To test the switch, place a **temporary** jumper across the flow switch terminals. If the internal pump operates and there is DHW generated then the water flow switch is faulty and must be replaced.

Note: Switch orientation is critical for proper switch operation, The identification plate on the switch must face up and the arrow on the plate must point in the direction of flow.

Failure of the mixing valve will allow cold water to be mixed with the hot water from the DHW heat exchanger during a DHW draw regardless of the setting of the mixing valve or the temperature of the water leaving the DHW heat exchanger. The failure can be detected by observing the temperature of the three pipes connected to the mixing valve. If the “mix” temperature is luke warm or cool and the “hot” temperature is hot and the “cold” temperature is cold then the mixing valve is either faulty or incorrectly adjusted and must be replaced or adjusted.

DHW heat exchanger scaling may occur in some areas of the country where there are high concentrations of minerals in the water. These minerals may cause fouling of the DHW heat exchanger over an extended period of time (lime build up). Other minerals, which react more quickly in well systems (mostly magnesium), cause slime on the inside of the heat exchanger and prevent adequate heat transfer. These minerals must be filtered out by a special incoming water filter or by the addition of an inhibitor to protect the coil and provide acceptable water quality. Minerals may be removed when necessary by flushing the coil with a cleaner such as “Unlime®” or “Sizzle®”.

11.5 High Gas Consumption

Boilers operating with an improper air/fuel ratio are very inefficient and consequently, have very high gas consumption. Because efficiency is high when the CO₂ is high, boilers operating with low CO₂ (especially LP boilers) consume more gas. Adjust the CO₂ or O₂ for optimum efficiency. If no combustion analyzing equipment (CO₂ or O₂) is available then a proper adjustment of the air/fuel ratio (CO₂) can not be accomplished. However, by briefly sniffing the flue gases it is possible to determine if the CO₂ or O₂ is within the proper range. There is no significant flue gas odor when combustion is proper. A strong piercing smell indicates poor combustion and generally a lean mixture (low CO₂). Check gas valve calibration (offset adjustment) and adjust if indicated. Do not attempt to correct combustion by reorificing without an O₂ or CO₂ kit.

SECTION 12. Parts Identification

Item #	Description	EBP0110	EBP0175	EDP0110	EDP0175	EDN0110	EDN0175
1.	Pan, Combustion Chamber, Top	2400-502	2400-502	2400-449	2400-449	2400-449	2400-449
2.	Pan, Combustion Chamber, Bottom	2400-504	2400-504	2400-504	2400-504	2400-504	2400-504
3.	Insulation, Coil Cover	2400-506	2400-506	2400-506	2400-506	2400-506	2400-506
4.	Insulation, Boiler Coil	2400-508	2400-508	2400-508	2400-508	2400-508	2400-508
5.	Comb. Chamber/Coil Assy.	2400-510	2400-512	2400-510	2400-512	2400-510	2400-512
6.	Gasket, Burner	2400-514	2400-514	2400-514	2400-514	2400-514	2400-514
7.	Burner	2400-516	2400-518	2400-516	2400-518	2400-516	2400-518
8.	Transfer Tank	2400-650	2400-650	—	—	—	—
9.	Boiler Drain	2400-522	2400-522	2400-522	2400-522	2400-522	2400-522
10.	Blower, Combustion Air (with gasket)	2400-524	2400-524	2400-524	2400-524	2400-524	2400-524
11.	Gasket, Blower	2400-540	2400-540	2400-540	2400-540	2400-540	2400-540
12.	Ignitor / Flame Sensor (with gasket)	2400-526	2400-526	2400-526	2400-526	2400-526	2400-526
13.	Gasket, Ignitor / Flame Sensor	2400-528	2400-528	2400-528	2400-528	2400-528	2400-528
14.	Adjustable Cover, Fan Inlet	2400-142	2400-142	2400-142	2400-142	2400-142	2400-142
15.	Coin Vent	2400-530	2400-530	2400-530	2400-530	2400-530	2400-530
16.	Anti-Condensing Valve, Complete	2400-451	2400-451	—	—	—	—
17.	Water Flow Switch	2400-542	2400-542	—	—	—	—
18.	Safety Limit, 230°F	2400-550	2400-550	2400-550	2400-550	2400-550	2400-550
19.	Sensor, Tank	2400-445	2400-445	—	—	—	—
20.	Sensor, Supply	2400-445	2400-445	2400-445	2400-445	2400-445	2400-445
21.	Sensor, Return	2400-446	2400-446	2400-446	2400-446	2400-446	2400-446
22.	Thermostatic Union (not shown)	—	—	2400-030	2400-030	2400-447	2400-447
23.	Pump	2400-592	2400-386	2400-592	2400-386	2400-388	2400-388
24.	Gaskets, Pump Flange	2400-566	2400-566	2400-566	2400-566	2400-566	2400-566
25.	Gas Valve	2400-548	2400-548	2400-548	2400-548	2400-548	2400-548
27.	Heat Exchanger, DHW	2400-570	2400-570	—	—	—	—
28.	Gaskets, DHW Heat Exchanger	2400-572	2400-572	—	—	—	—
29.	Boiler Control	2400-439	2400-439	2400-440	2400-440	2400-440	2400-440
30.	Ignition Control	2400-441	2400-441	2400-441	2400-441	2400-441	2400-441
31.	Reset Switch	2400-568	2400-568	2400-568	2400-568	2400-568	2400-568
32.	PWM Board	2400-442	2400-442	2400-442	2400-442	2400-442	2400-442
33.	Transformer	2400-448	2400-448	2400-448	2400-448	2400-448	2400-448
34.	Relay	—	—	R2006100	R2006100	R2006100	R2006100
35.	Wiring Harness (not shown)	2400-443	2400-443	2400-444	2400-444	2400-444	2400-444
36.	Gauge, Pressure	2400-574	2400-574	2400-574	2400-574	2400-574	2400-574
37.	Pressure Relief Valve	2400-112	2400-112	2400-112	2400-112	2400-112	2400-112
38.	Orifice Kit 0-5000' (not shown)	2400-145	2400-145	2400-145	2400-145	2400-145	2400-145
39.	Orifice Kit High Altitude (not shown)	2400-146	2400-146	2400-146	2400-146	2400-146	2400-146
40.	Rectifier & gas valve on/off switch	R0560701	R0560701	R0560701	R0560701	R0560701	R0560701
41.	Dip Tube, Transfer Tank	R0560801	R0560801	—	—	—	—

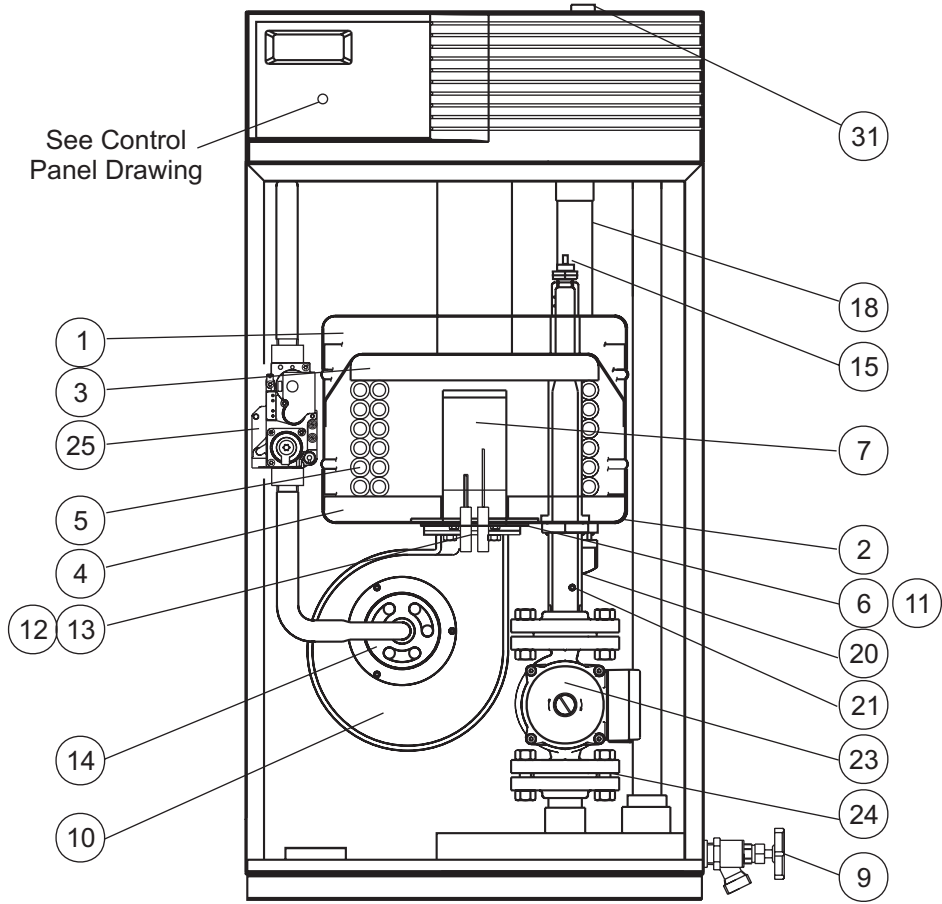

Model EDP/EDN

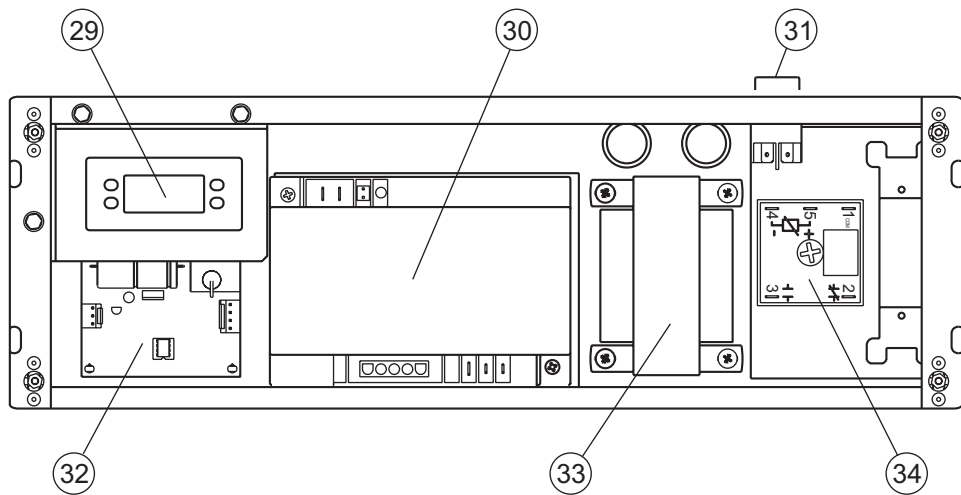

Model EBP/EDP/EDN Control Panel

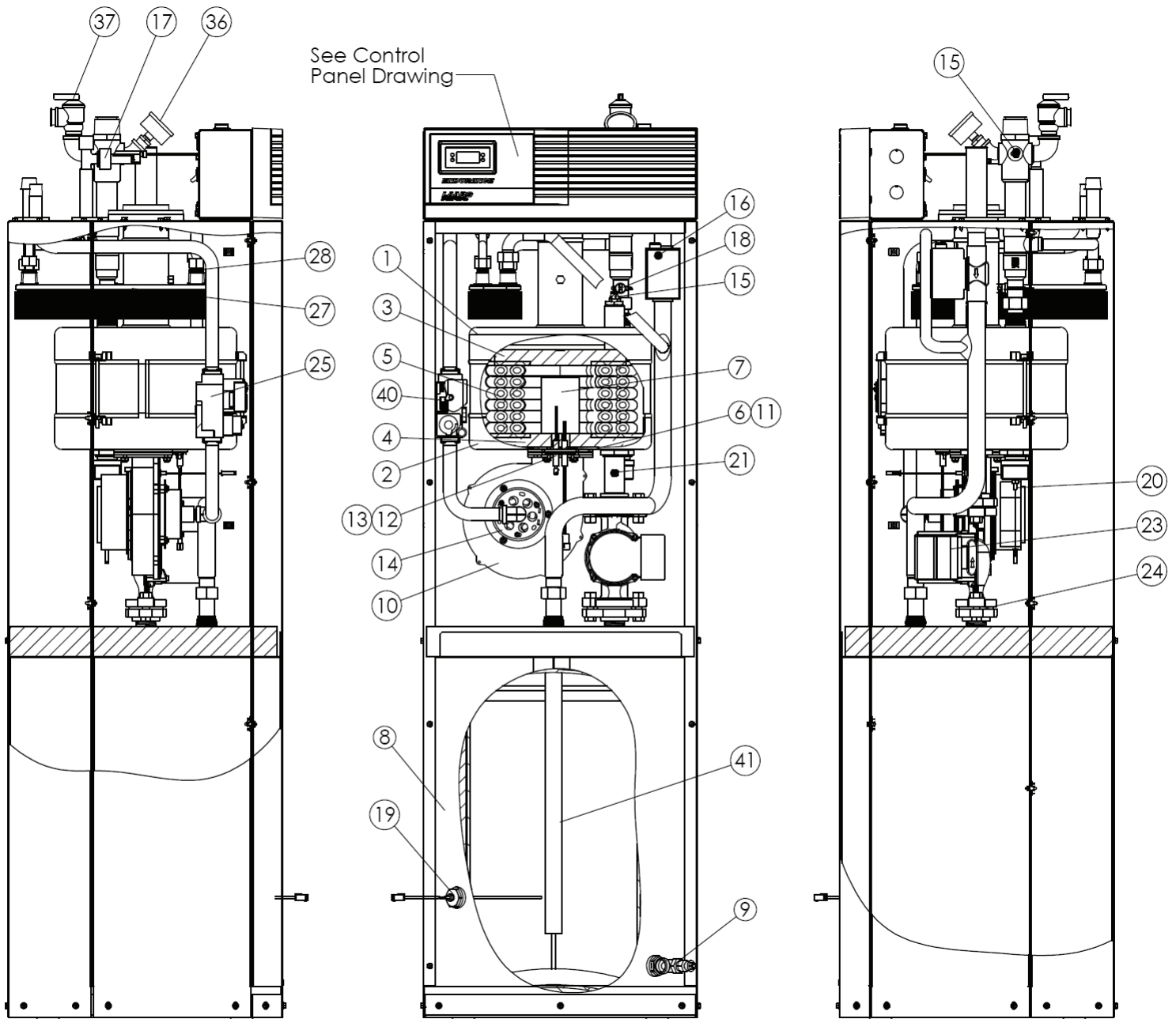

H2313500D

LAARS 

Heating Systems Company
A subsidiary of BRADFORD WHITE Corporation

20 Industrial Way, Rochester, NH 03867 • 603.335.6300 • Fax 603.335.3355
 1355 Kuehner Drive, Simi Valley, CA 93063 • 800.900.9276 • Fax 800.559.1583 (Sales, Service)
 1869 Sismet Road, Mississauga, Ontario, Canada L4W 1W8 • 905.238.0100 • Fax 905.238.0105
www.Laars.com

Litho in U.S.A. © Laars Heating Systems 0709 Document 1187D