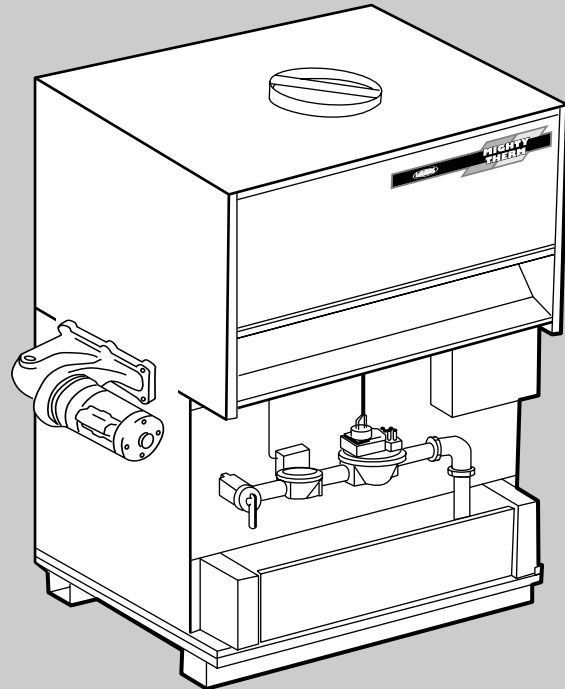
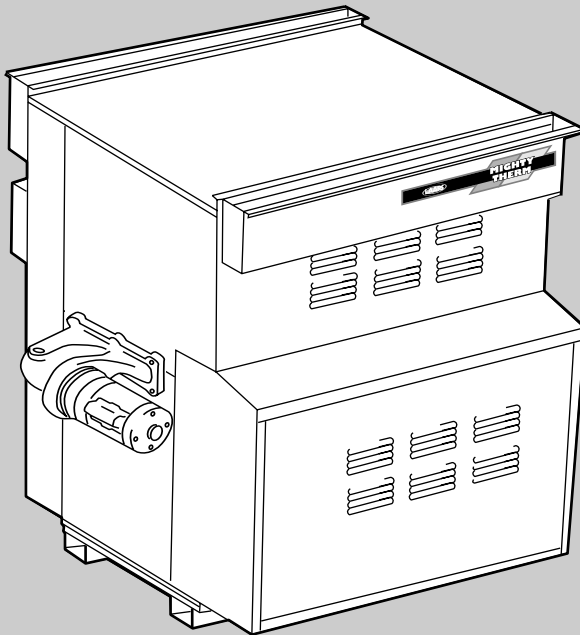


# Installation and Operation Instructions for **Mighty Therm**



## Volume Water Heaters Models VW, PW and IW Sizes 500-1825

These instructions are to be stored in the pocket provided on the boiler.

**FOR YOUR SAFETY:** This product must be installed and serviced by a professional service technician, qualified in hot water heater installation and maintenance. Improper installation and/or operation could create carbon monoxide gas in flue gases which could cause serious injury, property damage, or death. Improper installation and/or operation will void the warranty.

### **⚠ WARNING**

If the information in this manual is not followed exactly, a fire or explosion may result causing property damage, personal injury or loss of life.

Do not store or use gasoline or other flammable vapors and liquids in the vicinity of this or any other appliance.

#### WHAT TO DO IF YOU SMELL GAS

- Do not try to light any appliance.
- Do not touch any electrical switch; do not use any phone in your building.
- Immediately call your gas supplier from a nearby phone. Follow the gas supplier's instructions.
- If you cannot reach your gas supplier, call the fire department.

Installation and service must be performed by a qualified installer, service agency, or gas supplier.

**TABLE OF CONTENTS****SECTION 1.****General Information**

1A.	Introduction .....	3
1B.	Heater Identification .....	3
1C.	Flow Requirements .....	4
1D.	Water Chemistry .....	4

**SECTION 2.****Installation**

2A.	Heater Placement .....	4
2B.	Installation of Indoor Heaters .....	4
2B-1.	Combustion Air Supply .....	6
2B-2.	Venting .....	6
2C.	Installation of Outdoor Heaters .....	7
2D.	Gas Supply and Piping .....	7
2E.	Electrical Wiring .....	8
2F.	Water Piping of System .....	8
2G.	Water Expansion .....	9
2H.	Pump Performance and Installation .....	10
2I.	Water Pressure .....	16
2J.	Tank Installation .....	16
2K.	Two-Temperature System .....	16

**SECTION 3.****Operation**

3A.	Controls - General .....	16
3B.	Initial Start-Up .....	17

3C.	To Start Up System .....	18
3D.	To Turn Off Heater .....	19
3E.	To Shut Down System .....	19

**SECTION 4.****Maintenance**

.....	19
-------	----

**SECTION 5.****Troubleshooting and Analysis of Service Problems**

.....	20
-------	----

**SECTION 6.****Parts Descriptions and Order Numbers**

.....	22
-------	----

**SECTION 7.****Outdoor Parts Descriptions and Order Numbers**

.....	30
-------	----

**SECTION 8.****Optional Parts Descriptions and Order Numbers**

.....	32
-------	----

**SECTION 1.  
General Information**

**1A. Introduction**

This manual provides information for the installation and operation of Laars volume water heaters. It is strongly recommended that all application and installation procedures be reviewed completely before proceeding with the installation. Consult the Laars factory, or local factory representative, with any problems or questions regarding this equipment. Experience has shown that most problems are caused by improper installation.

Some accessory items are shipped in separate packages. Verify receipt of all packages listed on the package slip. Inspect everything for possible damage upon delivery, and inform the carrier of any shortages or impairments. Any such claims should be filed with the carrier. The carrier, not the shipper, is responsible for shortages and damage to the shipment whether visible or concealed.

**⚠ WARNING**

All volume water heaters must be installed in accordance with the procedures outlined in this manual. The warranty does not apply to heaters not installed or operated in accordance with these procedures. Consult local building and safety codes before proceeding with work. The installation must conform to the requirements of the authority having jurisdiction or, in the absence of such requirements, to the latest edition of the National Fuel Gas Code; ANSI Z223.1, National Electrical Code ANSI/NFPA 70 and/or in Canada CAN1-B149 requirement.

When required by the authority having jurisdiction, the installation must conform to American Society of Mechanical Engineers safety codes for controls and safety devices for automatically fired heaters No. CSD-1, and in Canada CGA 3.3. Any modification to the water heater, its gas controls, gas orifices, wiring or draft diverter may void the Laars warranty. If field conditions require such modifications, consult factory.

**1B. Heater Identification**

Consult rating plate on the heater. The following example simplifies the heater identification.

1	2	3	4	5	6
PW	1670	I	N	09	C

1. Basic heater model.\*
2. Input rate X 1000 BTU/hr.
3. Indoor (I) or Outdoor (E) installation.
4. Gas type: Natural (N) or Propane (P).
5. Ignition system: I.I.D. (09) or continuous pilot (16).\*\*
6. Firing rate: On/Off (C), 2-stage (K), 4-stage (L).

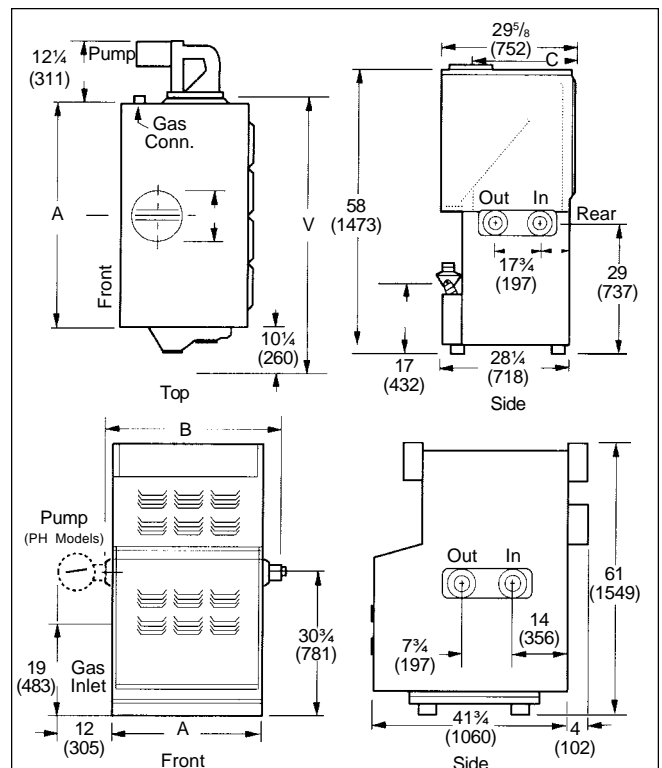
\***Model VW** water heaters for use with separate storage tank. There must be a field installed pump to circulate water between the heater and the storage tank.

\***Model PW** water heaters are basically the same as the VW series except that the PW heaters come with integrally mount pumps.

\***Model IW** water heaters are tankless instantaneous heaters, complete with mount pump for use in applications having a suitable diversity in heater load.

\*\***Special Options:** I.I.D. (04) 115 volts.

Laars commercial water heaters are available in two models: an indoor version and an outdoor version. Both are available from the factory (see Figure 1).



**Figure 1. Boiler Configuration.**

**1C. Flow Requirements**

For proper operation, all low volume hot water heaters must have continuous flow through the heat exchanger when firing. The system pump must be capable of developing sufficient pressure to overcome the resistance of the heater plus the entire circulating system at the designed flow rate.

**1D. Water Chemistry**

Laars equipment is designed for use in a wide variety of water conditions. The water velocity maintained in the heat exchanger tubes is kept high enough to prevent scaling from hard water and low enough to avoid corrosion from soft water. Ninety-five percent of the urban areas in the country have water that is compatible with this equipment, but in some areas a water supply will contain a large quantity of scaling chemicals or the water may be extremely soft and corrosive. In rare situations the water will contain both scaling chemicals and corrosive chemicals such as calcium or sodium chloride. These conditions may be the result of a nearby well or pumping station and the particular condition may not be characteristic of the entire city water system.

If an installer observes damage from these conditions to any water handling equipment in the area, a factory representative should be contacted immediately for assistance in minimizing maintenance costs. If erosion is present, the pump impeller can be replaced to reduce water velocity. If scaling conditions are bad, tube cleaning maintenance schedules can be established to prevent tube burn-out and cracking. Neglecting the problem could mean serious damage to the heater and water system.

Scaling can be recognized as a layer deposited on the inner walls of the tube which reduces the inner diameter of the tube. Scale can be any color or texture; smooth or rough, granular or amorphous. Signs of erosion are generally pitting, cavitation, ridges and "islands" on the inner walls of the tubes. Since this condition results from extremely soft water sources, or as a result of a water softening program, the internal copper surfaces will be extremely shiny. Other chemicals, such as chlorine or chlorides in the water, will cause dark surfaces of erosion.

In areas where the water supply is extremely corrosive, it is advisable to order the heater with cupro-nickel tubes in the exchanger.

***Damage From Scaling, Corrosion, or Erosion is Not Covered by the Warranty.***

**SECTION 2.  
Installation**

**2A. Heater Placement**

The heater must be placed to provide specific clearances on all sides for maintenance and inspection. There must also be minimum distances maintained from combustible surfaces. These clearances also apply to non-combustible materials because the heater requires air circulation for proper operation.

Heater should be mounted on a level surface. An integral combustible flooring base is provided as standard equipment on outdoor models. Indoor models can be installed on a combustible floor with a special base assembly which is available from the factory, or with a base that complies with local code requirements. See rating plate for part number of the base assembly.

*Do not install a heater on carpeting.*

Under the National Fuel Gas Code, ANSI Z223.1, it is permissible to place the heater on floors other than non-combustible when the installation complies with the American Insurance Code. Figures 2, 3, 4 and 5 show common installation on combustible flooring.

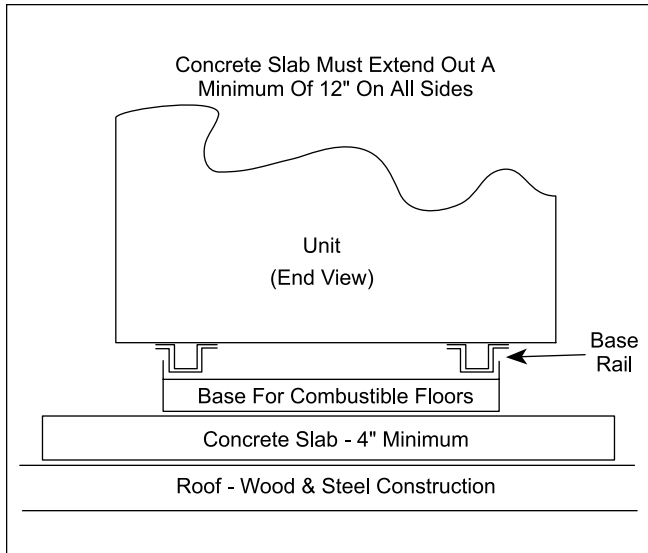
**2B. Installation of Indoor Heaters**

1. Locate the water heater to provide adequate clearance for inspection and service on all sides (see Table I). We recommend minimums of 24" from front (for proper access to and service of controls) and 18" at water connection end. For alcove installation (see Figure 6).
2. Install the heater on a waterproof floor with an adequate floor drain and a 6" minimum curb on all four sides to protect the building if heater repairs are required. ***The manufacturer will not be held liable for any water damage in connection with this heater.***

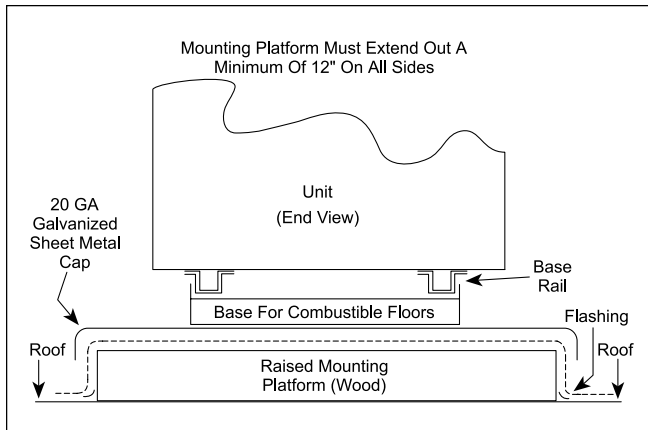
<b>Clearance From</b>	<b>Indoor (inches)</b>	<b>Outdoor (inches)</b>
Top	30	unobstruct
Water Conn. Side	12	24
Opposite Side	6	24
Front	Alcove	Unobstruct
Rear	8	24
Vent Pipe*	6	—
Hot Water Pipes	Per Code	Per Code

\*1" when using type B Vent (refer to Manufacturer's Instructions)

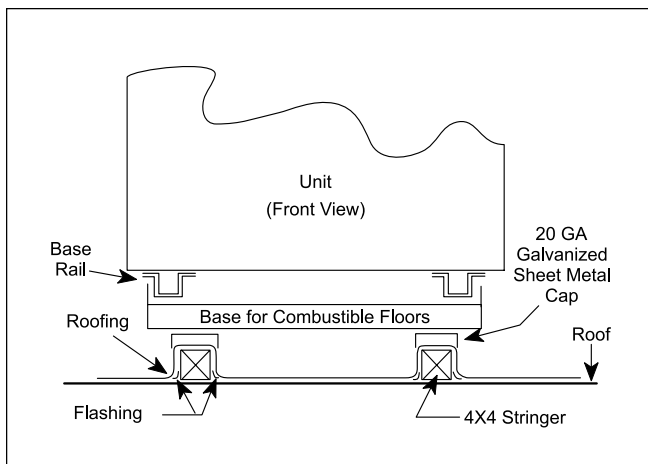
**Table 1. Minimum Boiler Clearances From Combustible Surfaces.**



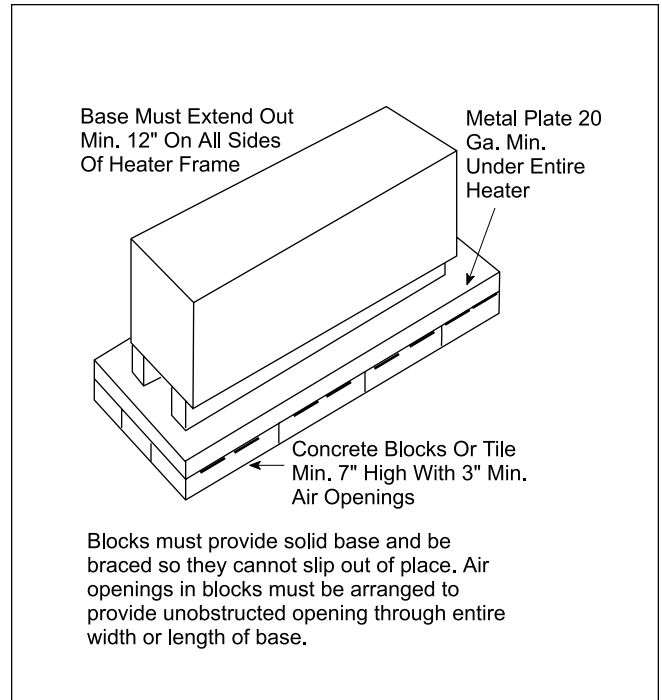
**Figure 2. Typical Heater Installation with Base for Combustible Floors, Example A.**



**Figure 3. Typical Heater Installation with Base for Combustible Floors, Example B.**



**Figure 4. Typical Heater Installation with Base for Combustible Floors, Example C.**



**Figure 5. Installation on Concrete Blocks or Tile.**

**CLOSET INSTALLATION (UNACCEPTABLE)**

A closet is any 4 sided enclosure which is less than 16\* times the total volume of all the gas fired appliances within the enclosure.

**ROOM INSTALLATION (ACCEPTABLE)**

A room is any enclosure which is at least 16\* times greater than the total volume of all the gas fired appliances within the enclosure.

**ALCOVE INSTALLATION (ACCEPTABLE)**

An alcove suitable for the installation of a water heater is a restricted section of a room not separated from the room by a door or partition and which meets the minimum clearances for the specific model water heater listed below.

\* When the ceiling height exceeds 8 feet, you are only allowed to consider 8 feet when calculating the total volume of the enclosure.

**Figure 6. Alcove Installation.**

**2B-1. Combustion Air Supply**

1. The heater location must provide sufficient air supply for proper combustion and ventilation of the surrounding area as outlined in the latest edition of ANSI standard Z223.1, and any local codes that may be applicable. Inadequate combustion air supply may result in incomplete combustion, sooting of the heat exchanger, and unsafe operation of the heater.
2. In general, these requirements specify that small heater rooms should be provided with two permanent air supply openings communicating directly through the wall to outside air; one within 12 inches of the ceiling, and the other within 12 inches of the floor. Each opening should have a minimum free area of one square inch per 4,000 BTUH input of the total input rating of all appliances in the enclosed area. See Table 2 for recommended air supply for each model. An improperly ventilated equipment room can get excessively hot and cause accelerated deterioration of controls and electrical components.

**IMPORTANT:** In beauty shops, barber shops, cleaning establishments and self-service laundries with dry cleaning equipment, it is important that the water heater be installed in a location where

combustion and ventilation air is received from a source outside the building. Please refer to the most recent edition of the National Fuel Gas Code, ANSI Z223.1, or in Canada, CGA requirements.

3. **(a) In the United States:** Exhaust Fans or Vents: Any equipment which exhausts air from the heater room can deplete the combustion air supply or reverse the natural draft action of the venting system. This could cause flue products to accumulate in the heater room. Additional air must be supplied to compensate for such exhaust. The information in Table 2 is not applicable in installations where exhaust fans or blowers of any type are used. Such installations must be designed by qualified engineers.  
**(b) In Canada:** Follow Canadian standard, CANI-B149 or local codes.
4. If a blower or fan is used to supply air to the heater room, the installer should make sure it does not create drafts which could cause nuisance shutdowns of the pilot. If a blower is necessary to provide adequate combustion air to the heater, a suitable switch or equivalent must be wired into the heater control circuit to prevent the heater from firing unless the blower is operating.
5. The heater must be completely isolated and protected from any source of corrosive chemical fumes such as trichlorethylene, perchlorethylene, chlorine, etc.

Heater Model	Each Opening* (Square Inches)
500	125
600	150
715	179
850	213
1010	253
1200	300
1430	358
1670	418
1825	457

\*Net Free Area in Square Inches

Area indicated is for one of two openings; one at floor level and one at the ceiling, so the total net free area could be double the figures indicated. For special conditions refer to the latest edition of ANSI Z223.1.

Consult factory if not communicating directly through the walls with the outdoors.

**Note:** Check with louver manufacturers for net free area of louvers. Correct for screen resistance to the net free area if a screen is installed. Check all local codes applicable to combustion air.

**2B-2. Venting**

1. Laars heaters have built-in draft diverters for natural draft operation and must not be connected to any portion of a mechanical draft system under positive pressure. The flue outlet must be connected to a clear, unobstructed vent of adequate capacity ending above the highest point of the building with an approved vent cap. The venting system should be installed according to the latest edition of ANSI Z223.1 and/or, in Canada, CAN1-B149 requirement and any local codes having jurisdiction.

**IMPORTANT NOTE:** Do not use sheet metal screws at the snap lock joints of Type B gas vents.

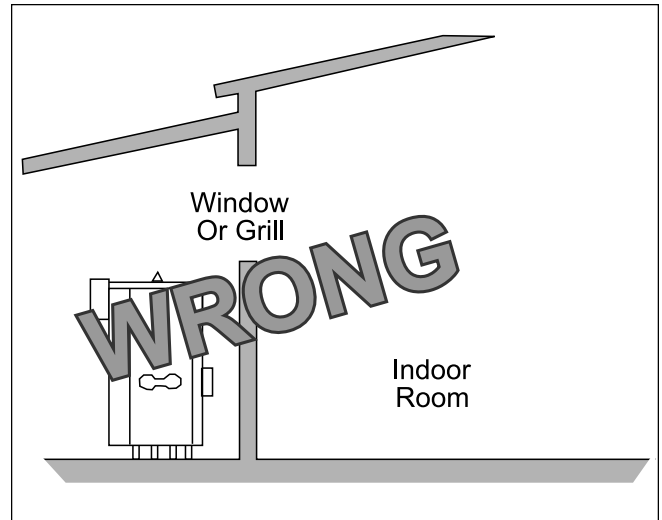
2. Do not weld or fasten the vent pipe to the heater draft hood. The weight of the stack must not rest on the heater. The draft hood and heater top must be easily removable for normal heater service and inspection.
3. Avoid using long horizontal runs of the vent pipe, and too many 90° elbows, reductions or restrictions. Horizontal runs should have at least a 1/4" rise per foot in the direction of flow. A vent connector should be supported for the design and weight of the material used to

**Table 2. Minimum Recommended Air Supply to Boiler.**

- maintain clearances and prevent physical damage and separation of joints.
- 4. Avoid ending heater vents near air conditioning or air supply fans. The fans can pick up exhaust flue products from the heater and return them inside the building, creating a possible health hazard. A minimum of 4 feet horizontal distance must be maintained from electrical meters, gas meters, and relief equipment.
- 5. Always use double-wall or insulated vent pipe (Type B or equivalent). In cold weather, uninsulated outside vents can chill the rising flue products, blocking the natural draft action of the venting system. This can create a health hazard by spilling flue products into the heater room.
- 6. Avoid oversize vent piping or extremely long runs of the pipe which may cause excessive cooling and condensation. Rule of Thumb: The total length of the vent, including the connector and any offset, should not exceed 15 feet for every inch of vent diameter. Longer total lengths shown in venting tables are based on maximum capacity, not condensation factors.
- 7. When the installation of a draft fan is necessary in connecting a venting system to a Laars heater, the installation should be engineered by competent personnel following good engineering practices. The draft fan supplier should be consulted for correct size. The installation should be in accordance with the latest edition of ANSI Z223.1 and/or, in Canada, CAN1-B149 requirement and any local codes having jurisdiction. When a draft fan is installed, a suitable draft switch must be wired into the heater control circuit at terminal designated "Field Interlock" to prevent firing of the heater unless a positive draft has been established.

**2C. Installation of Outdoor Heaters**

- 1. Locate the heater to provide the minimum clearances as listed in Table 1, "Placement of Heater".
- 2. Do not place the heater in an enclosure or wall recess. Avoid locations where wind deflection off structures might cause down draft. When such wind conditions are possible, place the heater at least three (3) feet from the structures.
- 3. Never install the heater under any kind of roof overhang. Do not place the heater below or adjacent to any doors, windows, louvers, grills, etc. which connect in any way with an inhabited area of a building. This includes other structures such as garages or utility rooms (see Figure 7).
- 4. Although these models are AGA and CGA designed certified for outdoor installations, such installations are not recommended in areas where



**Figure 7. Incorrect Outdoor Installation.**

the danger of freezing exists unless proper precautions are taken for freeze protection.

**2D. Gas Supply and Piping**

Review the following instructions before proceeding with the installation.

- 1. Verify that the heater is fitted for the proper type of gas by checking the rating plate. Laars heaters are normally equipped to operate below a 2000 foot altitude. Heaters equipped to operate at higher altitudes have appropriate stickers or tags attached.
- 2. Use the figures in Table 3 to provide adequate gas piping from the gas meter to the heater.
- 3. A trap (drip leg) must be provided ahead of the gas controls (see Figure 8 ). A manual gas shutoff valve must also be provided for service convenience and safety. Check the local codes.

Size	Distance from Gas Meter or Last Stage Regulator		
	0-100'	100-200'	200-300'
500	1-1/2"	2"	2"
600	1-1/2"	2"	2-1/2"
715	2"	2"	2-1/2"
850	2"	2-1/2"	2-1/2"
1010	2"	2-1/2"	3"
1200	2-1/2"	3"	3"
1430	2-1/2"	3"	3"
1670	2-1/2"	3"	3"
1825	2-1/2"	3"	3-1/2"

**Note:** These figures are for Natural Gas (.65 Sp. Gr.), and are based on 1/2" water column pressure drop. Check supply pressure with a manometer, and local code requirements for variations. **For LPG,** reduce pipe diameter one size, but maintain a 1" minimum diameter. A normal number of Tees and elbows have been taken into allowance.

**Table 3. Gas Piping Sizes.**

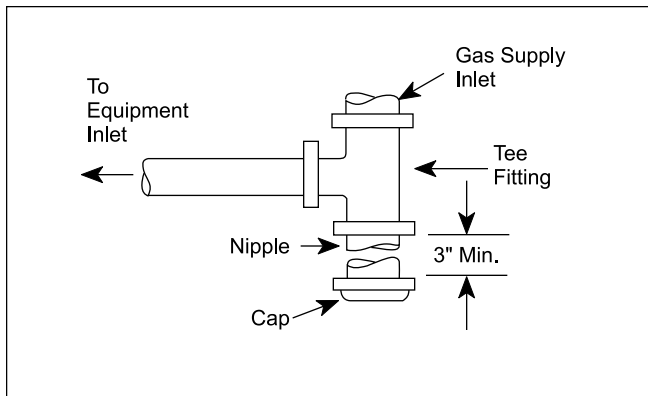


Figure 8. T-Fitting Sediment Trap Installation.

- The boiler and its individual shutoff valve must be disconnected from the gas supply piping system during any pressure testing of that system at test pressures in excess of 1/2 psig. The boiler must be isolated from the gas supply piping system by closing its individual manual gas shutoff valve during any pressure testing of the gas supply piping system at test pressures equal to or less than 1/2 psig.
- Provide gas supply pressure to the heater as follows:

	Natural Gas	LPG
Min. (inches water column)	Per Rating Plate	
Max. (inches water column)	9	14

**Note:** The heater and all other gas appliances sharing the heater gas supply line must be firing at maximum capacity to properly measure the inlet supply pressure. Low gas pressure could be an indication of an undersized gas meter and/or obstructed gas supply line.

- The correct burner manifold gas pressure is stamped on the rating plate. The regulator is preset at the factory and normally requires no further adjustment.
- The gas manifold and control assembly was tested and conform to the safe lighting and other performance criteria specified in the latest editions of ANSI Z21.13 and CGA 3.3 Low Pressure Boiler Standard.
- Before operating the boiler, the complete gas supply system and all connections must be tested for leaks using a soap solution. **Do not use raw flame.**

### ⚠ Caution

Since some leak test solutions (including soap and water) may cause corrosion or stress cracking, the piping must be rinsed with water after testing, unless it has been determined that the leak test solution is noncorrosive.

## 2E. Electrical Wiring

### ⚠ WARNING

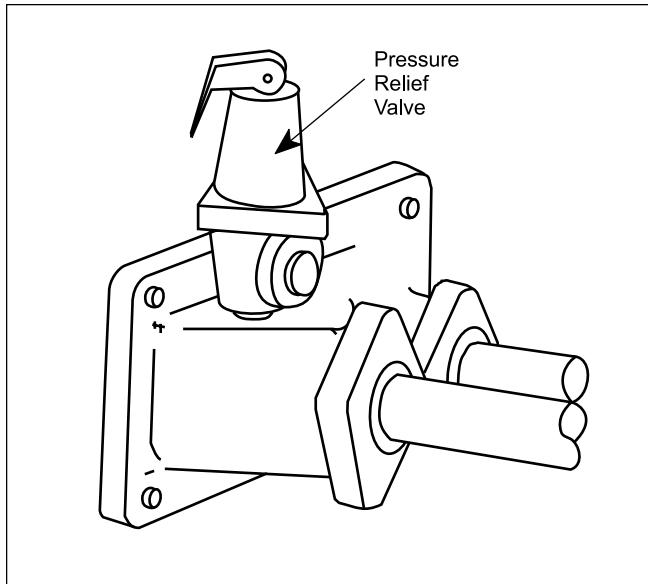
The heater must be electrically grounded in accordance with the most recent edition of the National Electrical Code, ANSI/NPA 70. In Canada, all electrical wiring to the heater should be in accordance with the Canadian Electrical Code, CSA C22.1 Part 1. Do not rely on the gas or water piping to ground the metal parts of the heater. Oftentimes, plastic pipe or dielectric unions isolate the heater electrically. Service and maintenance personnel who work on or around the heater may be standing on wet floors and could be electrocuted by an underground heater.

- Check heater wiring and pump for correct voltage, frequency and phase. If the pump circuit is other than 115V, check to see that the heater is provided with an appropriate transformer.
- Wire the heater and pump exactly as shown in the wiring diagram supplied with the heater.
- The pump and heater must be electrically interlocked so the heater cannot come on unless the pump is running.
- All field installed electrical safety devices and all field installed devices (draft switches, relays, timers, outdoor temperature reset devices, etc.) can be connected to the heater wiring at points shown in the wiring diagram designated "Field Interlock".

## 2F. Water Piping of System

- Be sure to provide valves at the inlet and outlet of the boiler so it can be readily isolated for service. A butterfly or similar type of valve is recommended.
- The pressure relief valve installed in the tapped opening provided in the outlet header (see Figure 9), must be piped, but not fastened, to a drain or floor sink. The drain pipe must be the same size as the valve outlet and must pitch downward from the valve.

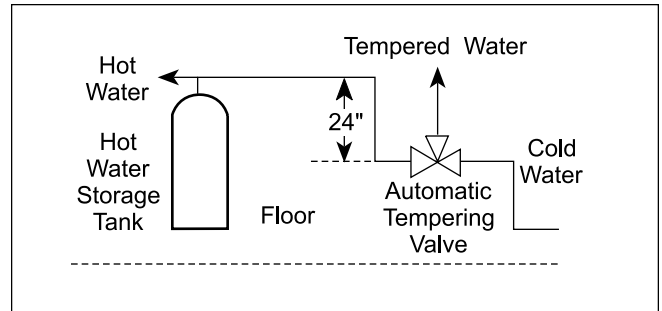




**Figure 9. Pressure Relief Valve Location.**

Special attention must be given to relief valve settings in installations where the heater is located on the ground floor of a tall building. The static pressure of the system is elevated and could cause the relief valve to leak. *Where no special setting of the relief valve is ordered, the factory will furnish a 125 psi setting.* Never reduce the relief valve openings.

3. Pressure relief valve lever must be tripped at least once a year to insure that waterways are clean. When manually operating lever, water will discharge through drain line. Precautions must be taken to avoid contact with hot water and water damage.
4. The weight of all water and gas piping should be supported by suitable hangers or floor stands.
5. Check piping diagrams with local applicable plumbing, heating and building safety codes.
6. All two-temperature systems using temperature valves must have forced recirculation in the low temperature building loop.
7. A check valve installed at the hot water inlet to the tempering valve will prevent cold water from being drawn in reverse through the tempering valve into the hot water.
8. When installing a tempering valve, place at bottom of antithermosyphon loop at least 24" high to prevent excessive hot water from entering mixed water supply. Bring the cold water supply up from the floor to the valve (see Figure 10).



**Figure 10. Tempering Valve Installation.**

## 2G. Water Expansion

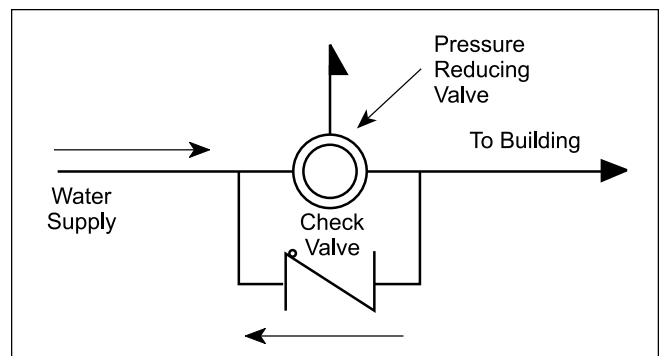
When cold water is heated the water expands. If no water is being used during the heat-up period the expanded water will normally back up into the city mains.

A water pressure reducing valve installed in the incoming cold water line may act as a check valve and prevent the expanded water from moving backward. This will cause pressure to rise in the heater, which will be relieved by the pressure relief valve.

If the relief valve pops frequently a mineral deposit may build up on the valve seat, causing it to leak.

The following suggestions may solve the problem:

1. Install a properly sized expansion tank.
2. Replace the installed water pressure reducing valve with a suitable valve having a back flow port. These valves have a back flow port which allows water to flow backwards when the pressure in the system exceeds the pressure in the mains.
3. Install a check valve around the pressure reducing valve to permit reverse flow. This will allow the expanded water to back flow into the mains.



4. Install an auxiliary small relief valve set at 25 psi less than the main relief valve. The valve must be piped to a drain and may require occasional cleaning. It will bleed off the expanded water and protect the main pressure relief valve from becoming fouled.

**2H. Pump Performance and Installation**

1. The factory provided pump on **PW** heaters and the recommended field provided pump for model **VW** heaters are sized to provide proper circulation through the heater and heater-to-tank circulation loop (see Figures 11 and 12). If the heater-to-tank circulating loop **does not contain more than 6 elbows or 30 feet of pipe**, use pipe fittings in the loop no smaller than the following:

Model	Pipe Size
500 through 850 1010 through 1825	2" 2-1/2"

If the heater-to-tank circulating loop contains **more than 6 elbows or 30 feet of pipe**, use pipe or fittings in the loop no smaller than the following:

Model	Pipe Size
500 through 850 1010 through 1825	2-1/2" 3"

To assure free circulation, do not use globe valves, side outlet tee connections or other restrictive fittings in heater-to-tank loop.

2. The Model **IW** heater is designed for use in a system without a hot water storage tank. The hot water supply line to usage point must have a return leg to the heater (see Figure 13, 14 and 15). A built-in circulating pump and internal heat exchanger bypass maintains the heater in a standby condition. It also maintains the temperature at the controller setting of the water in the entire building circulating loop whether or not there is any use of hot water.

A separate circulating pump is required for circulation of water in the building loop. The control system provides variable heat inputs to match periods of higher or lower water consumption.

3. The Model **IW** heater requires a minimum of circulating hot water in the building circulation loop. To prevent excessive temperature fluctuations in the delivered water, the whole building system, including the return loop, must have the equivalent volume of pipe shown below:

Model IW	Minimum Reservoir Gallons*	Equivalent Pipe Size and Length
500 through 850 .....	6.3 .....	1 1/4" x 100 ft.
1010 through 1220 .....	10.2 .....	1 1/2" x 100 ft.
1430 through 1670 .....	17.0 .....	2" x 100 ft.
1825 .....	27.0 .....	2 1/2" x 100 ft.

\* The gallons shown are the calculated volumes of the pipes.

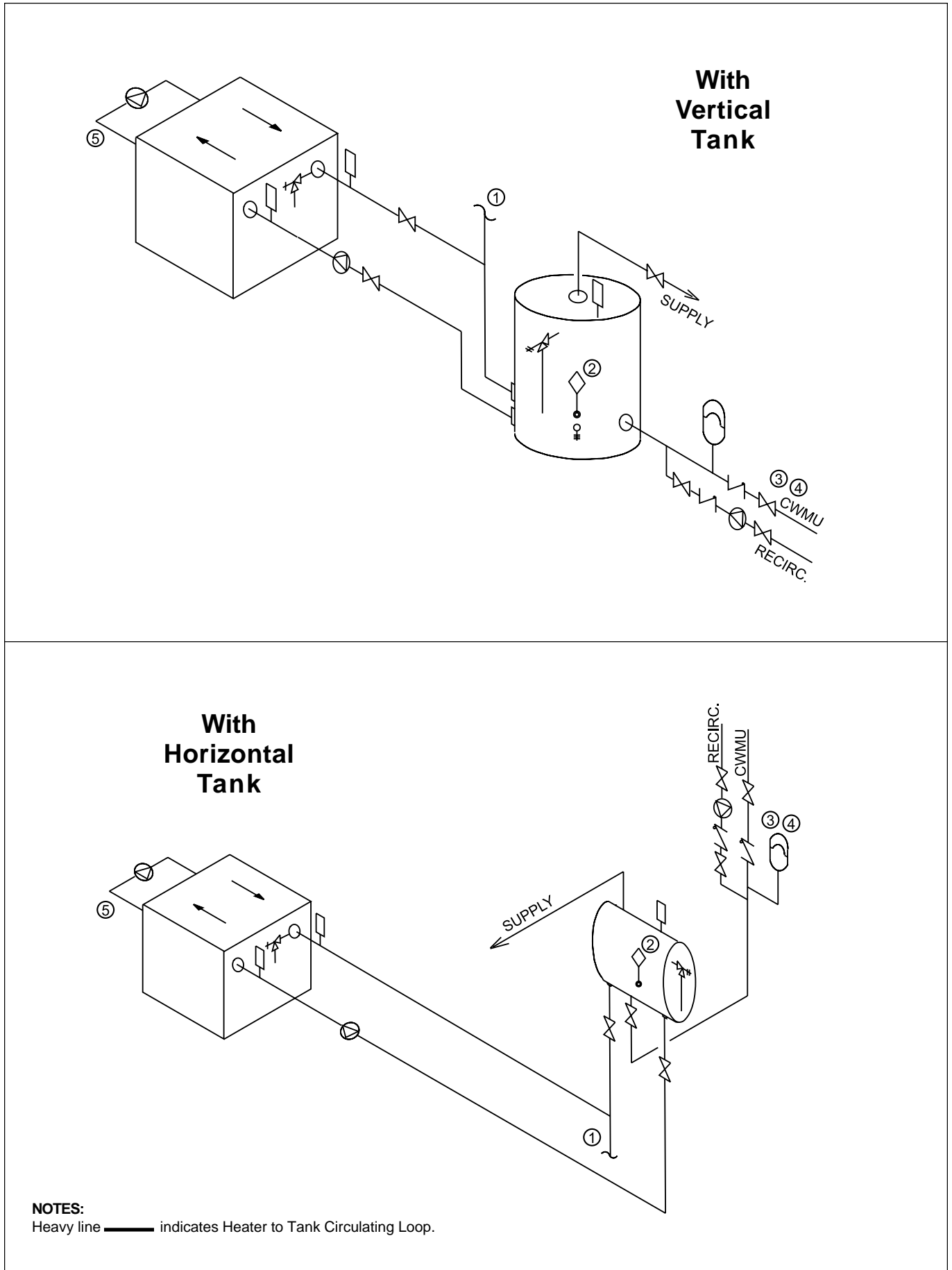
4. Model **VW**, **PW** and **IW** heaters are not suitable for heating swimming pools or any other application where temperature of the water flowing through the heater remains below the dew point (110°F).

In applications requiring the rapid use of measured volumes of water, the recovery of the heater between the time intervals of use must equal the volume used. See the recovery table in the current **Document 2045 (Submittal Data)**.

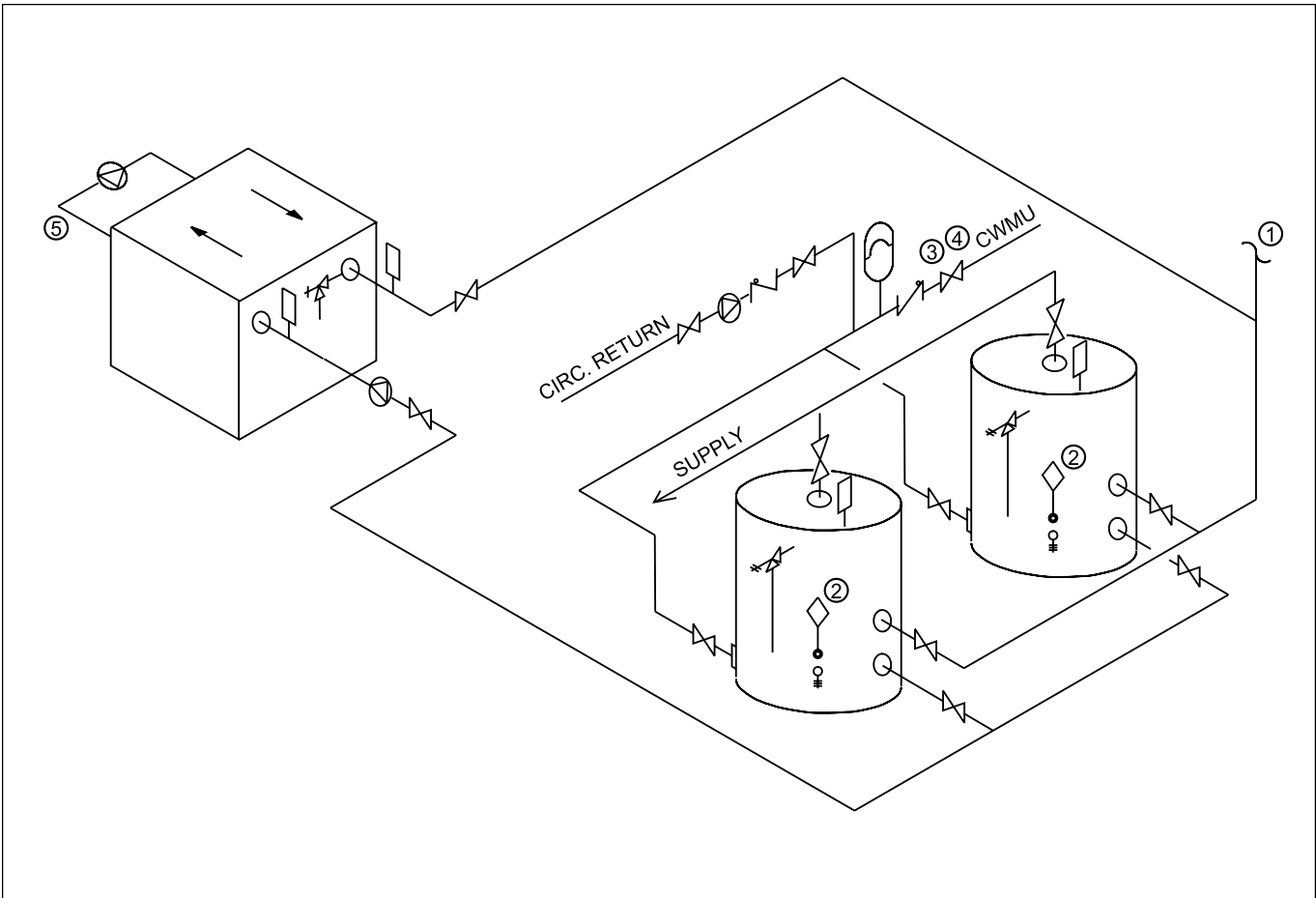
5. Pump Sizing: A suitable pump must be field-provided for circulation of water between Model **VW** heaters and the storage tank. This pump must be sized to avoid excessive temperature rise and to provide correct flow for water hardness conditions. Specifications in Table 4 include allowance for 30 feet of piping and normal fittings between heater and tank.
6. Install pump in a cool location. When pump is installed where it is subjected to excessive heat, the life of the pump will be shortened. Heat will embrittle motor insulation and dry out bearing lubricants. If the pump motor is equipped with thermal protection, excessive heat may trip the thermal switch and shut down the pump intermittently. This could result in rapid scaling of the heater.

**IMPORTANT:** Check oil level in pump before starting. Oil pump every three (3) months. Fill bearing assembly to lower level of overflow vent. Add five (5) or six (6) drops of oil to front and rear of motor. Use 20W non-detergent oil. Pumps located in excessively hot or dusty locations should be oiled once a month. Self lubricating pumps do not require oiling.

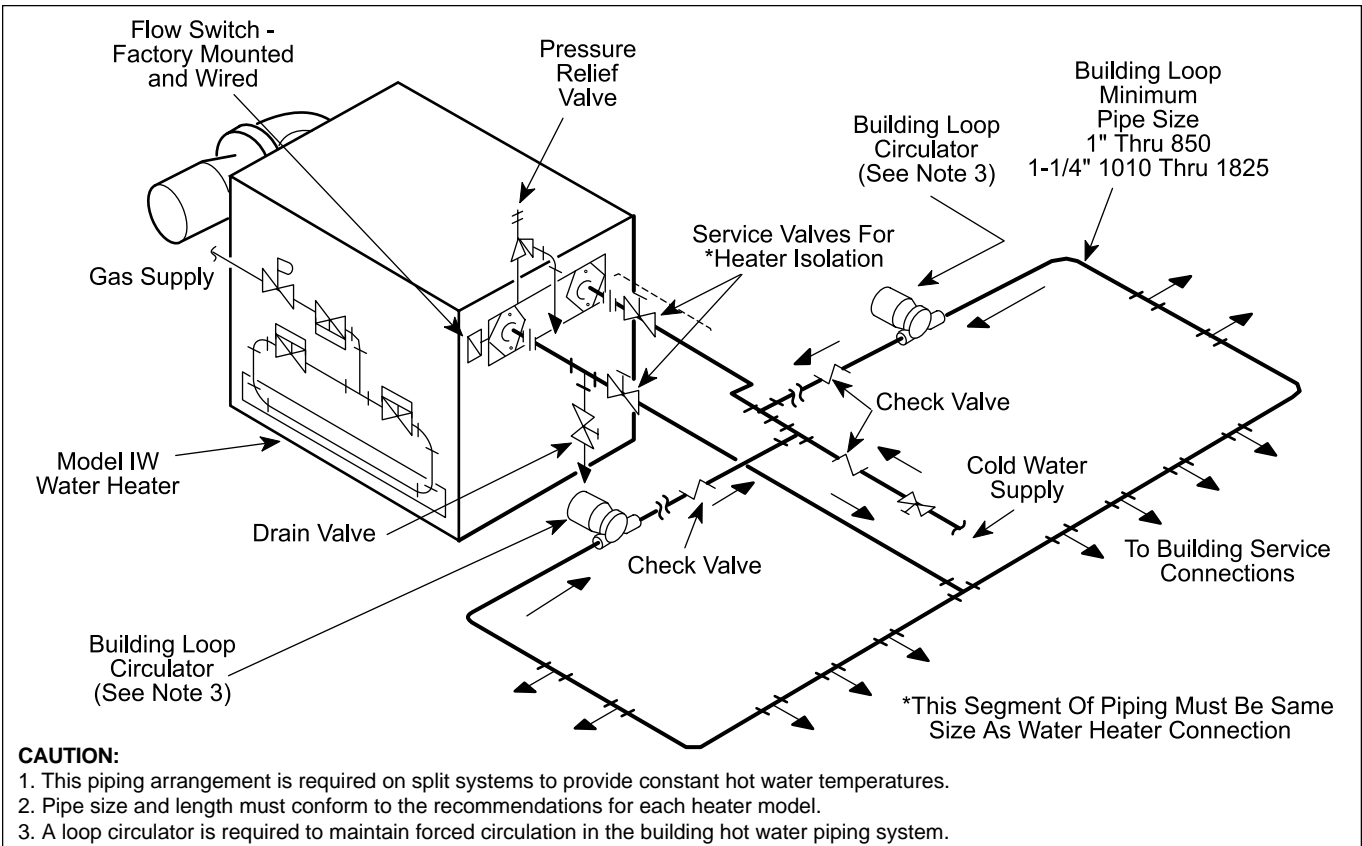
7. The pump should be accessible for lubrication, inspection and service.
8. If pump is designed for floor mounting, install securely on concrete block or pad at least six (6) inches above floor level. This will prevent flooding of motor when floor is washed. Be sure that floor mounted pumps are not suspended from piping and that piping is plumbed to avoid strain on the pump casing.



**Figure 11. Hot Water Supply System (Model VW & PW).**



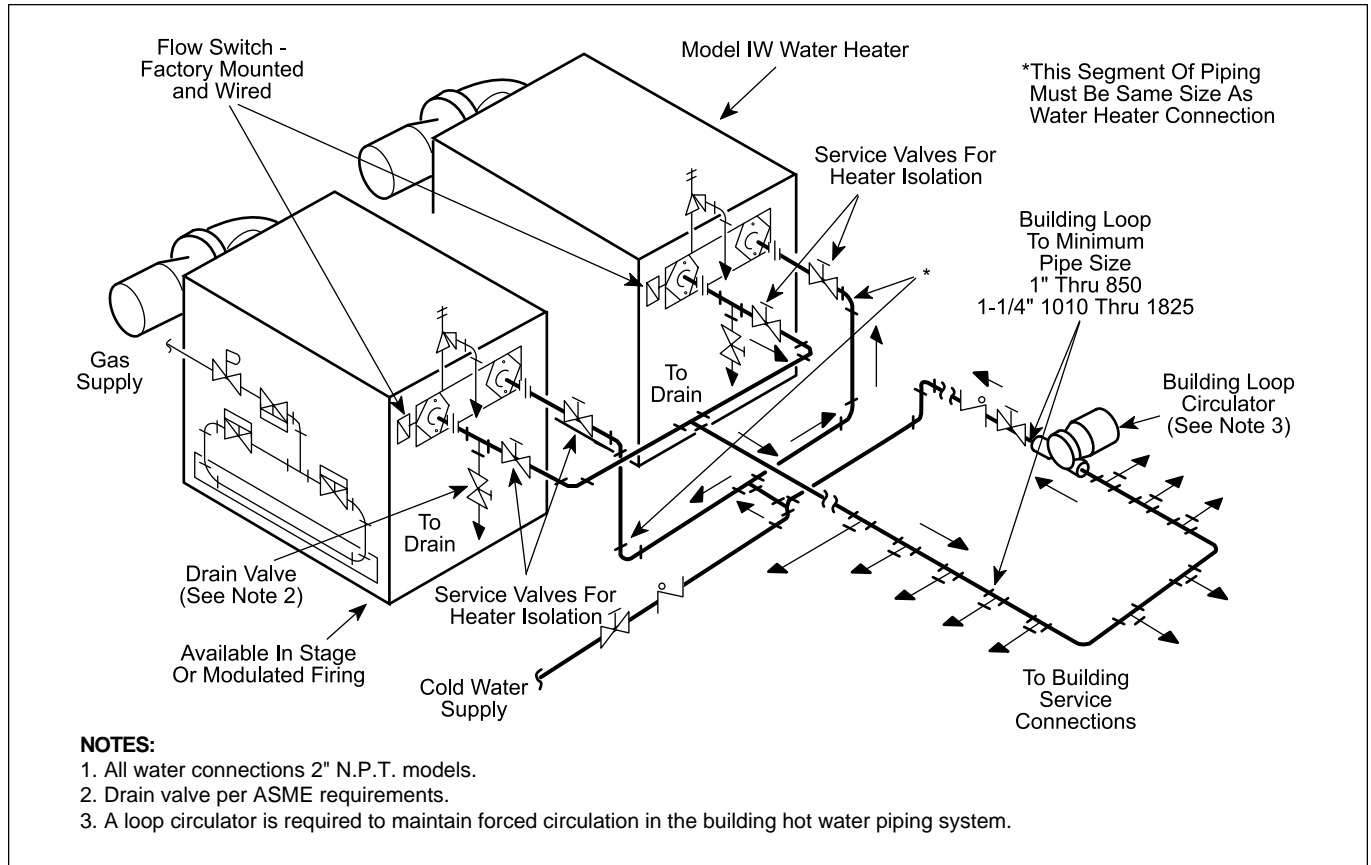
**Figure 12. Hot Water Supply System Using Model PW with Dual Tanks, Building Loop Return and Circulating Pump.**



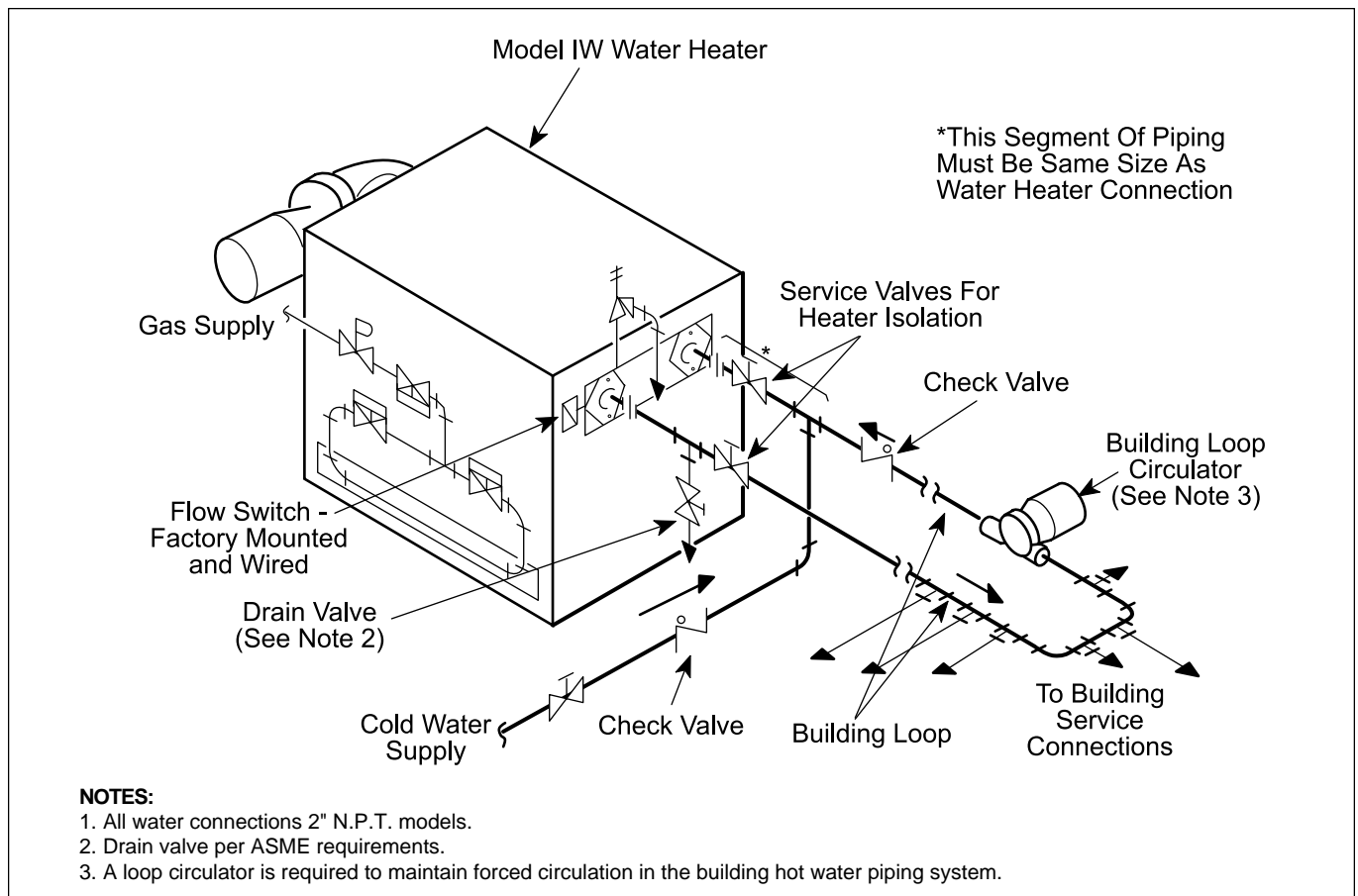
**CAUTION:**

1. This piping arrangement is required on split systems to provide constant hot water temperatures.
2. Pipe size and length must conform to the recommendations for each heater model.
3. A loop circulator is required to maintain forced circulation in the building hot water piping system.

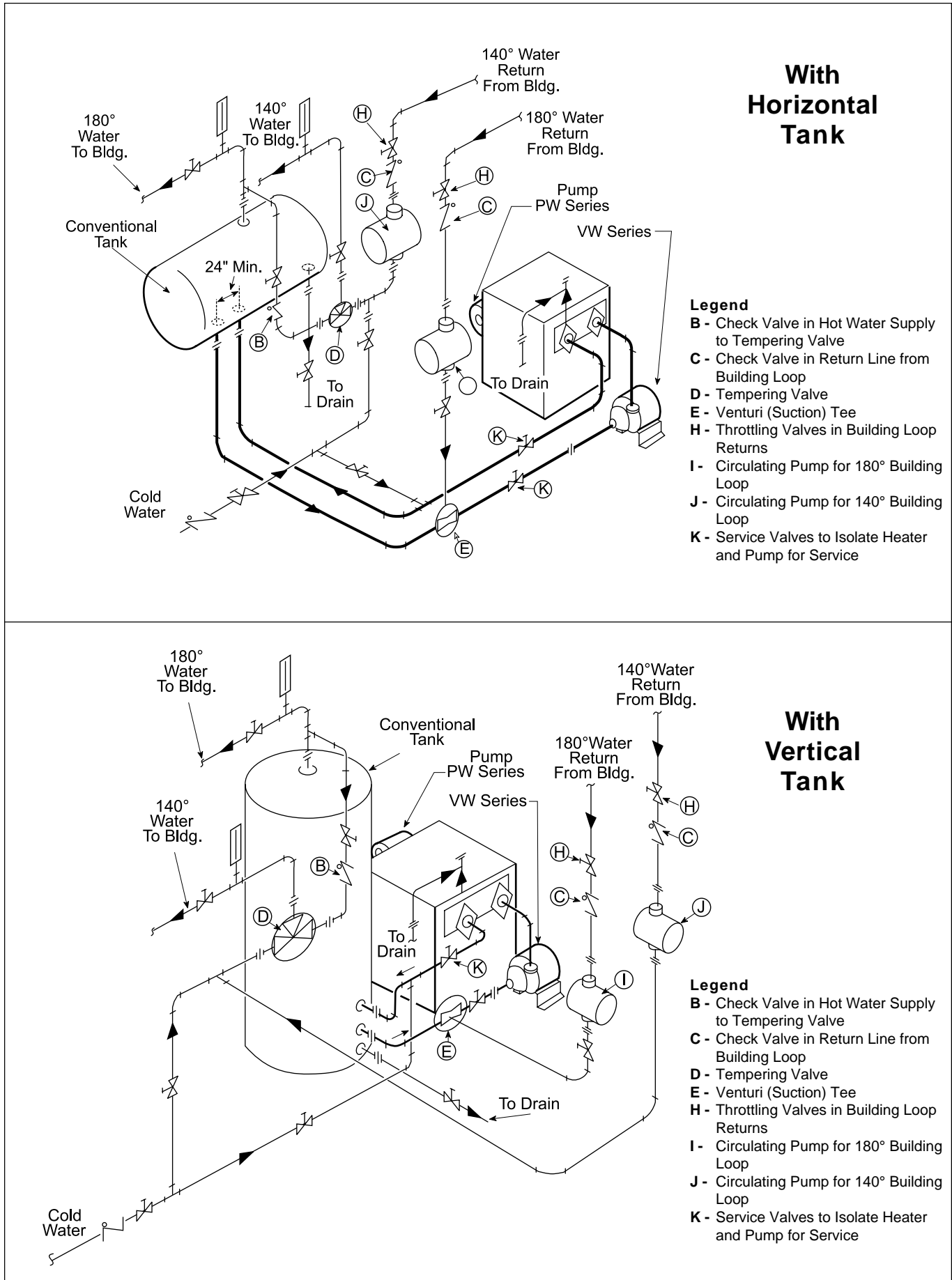
**Figure 13. Split System Piping Diagram, Model IW.**



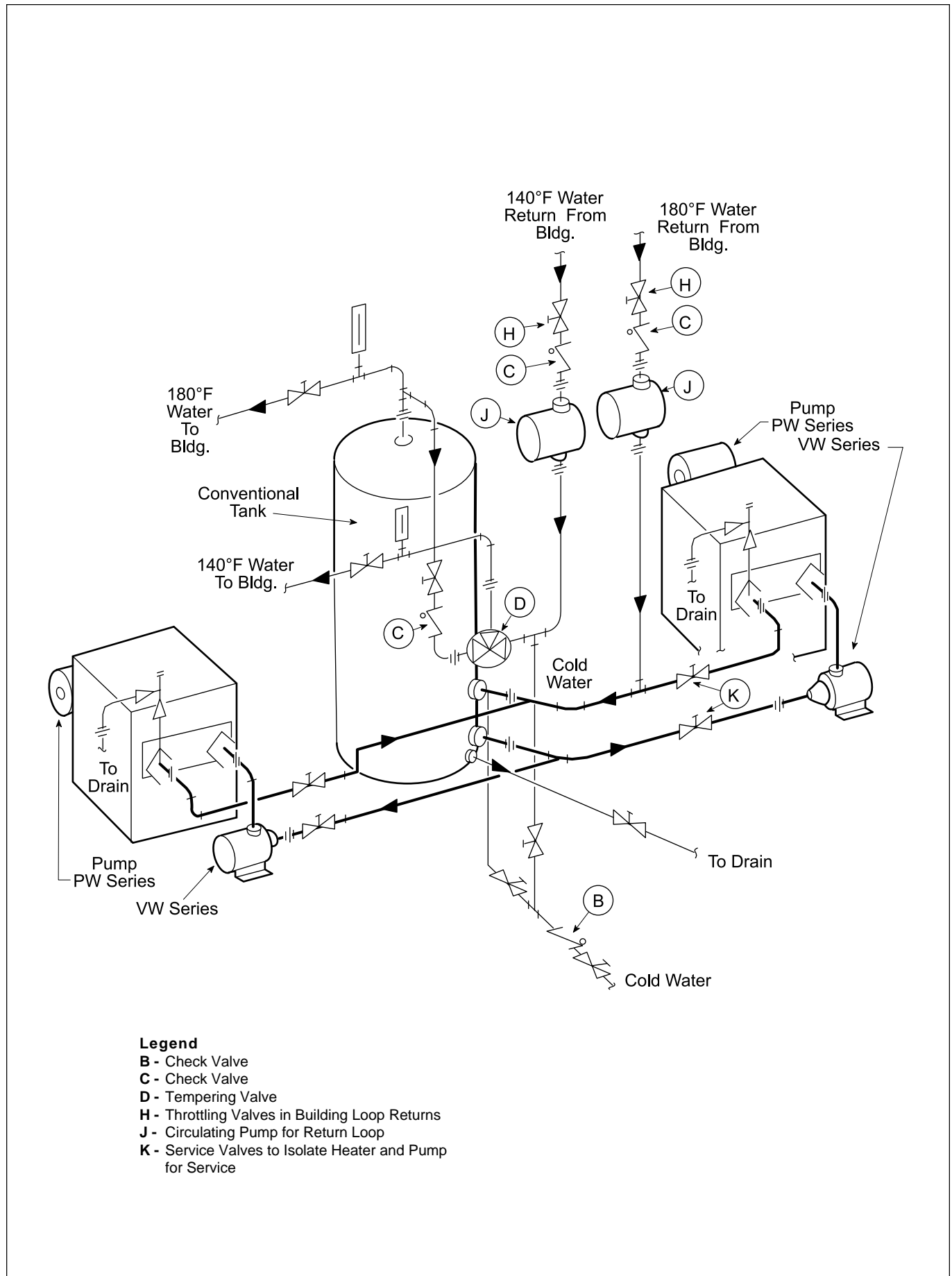
**Figure 14. Dual Installation Piping Diagram, Model IW.**



**Figure 15. Single Installation Piping Diagram, Model IW.**



**Figure 16. Two-Temperature Hot Water Supply System (Model VW or PW).**



**Figure 17. Two-Temperature Hot Water Supply System with Vertical Tank for Models VW and PW Water Heaters.**

Model	Water Category	Flow Rate (GPM)	Head* Loss (ft.)	Temp. Rise Across Heater, (°F)
500	Soft	45	5.0	17
	Normal	68	9.9	11
	Hard	90	15.7	8
600	Soft	45	5.1	20
	Normal	68	10.0	14
	Hard	90	15.9	10
715	Soft	45	5.3	24
	Normal	68	11.0	16
	Hard	90	17.8	12
850	Soft	45	5.4	30
	Normal	68	11.1	20
	Hard	90	18.1	15
1010	Soft	45	3.9	35
	Normal	68	7.5	23
	Hard	90	11.7	18
1200	Soft**	68	7.8	27
	Normal	68	7.8	27
	Hard	90	12.2	21
1430	Soft**	68	8.1	32
	Normal	68	8.1	32
	Hard	90	12.6	24
1670	Soft**	68	8.3	37
	Normal	68	8.3	37
	Hard	90	13.0	28
1825	Soft**	90	13.5	30
	Normal**	90	13.5	30
	Hard	90	13.5	30
<b>Water Category</b> Soft Normal Hard		<b>Grain Hardness per Gal.</b> 1 through 7.5 7.6 through 17 Over 17		
<small>* Pressure drop includes loss through 30 feet of pipe and normal fittings when heater is installed with storage tank. Pipe and fittings are assumed to be 2" on Models (500-850) and 2 1/2" on Models (1010-1825)</small>				
<small>** To prevent erosion, these models must be ordered with cupro-nickel heat exchanger tubes.</small>				

**Table 4. Pump Performance Requirements.**

**2I. Water Pressure**

It is very important that water pressure in the system be maintained above 30 psi. If the system pressure should drop below this, the vapor pressure of water in the suction side of the pump can cause hammer and cavitation in the pump and damage the heater through lack of water circulation. If for any reason the **water supply is turned off temporarily** to service a piece of equipment, the **manual gas valve on the Model IW should be closed** until the water pressure has been restored and the lines bled of accumulated air. If the heater fails to fire when it is turned back on, it may be airlocked. To eliminate the airlock, open the pressure relief valve and allow air to bleed out until water flows. As soon as full circulation is resumed, the entrained air will be carried out through the hot water faucets.

**2J. Tank Installation**

1. Be sure the floor is waterproof and structurally capable of supporting the tank when it is filled with water.
2. The tank should be placed so that manholes, inspection covers, nameplates and drain valves are accessible.
3. Be sure the tank is suitable for the water in the system. Some water is corrosive and requires a protected tank with a special lining.
4. If the tank is glass-lined, it should be equipped with a suitable magnesium anode. It is good practice to replace the anode when it is approximately 50% used. The factory warranty on a glass-lined tank will be void if a satisfactory anode is not in place at the time of a failure or if it is consumed by cathodic action.
5. Make sure the tank connections in the heater-tank circulating loop are the proper size as listed in **Section 2H**. If tapings are smaller than the recommended pipe size, a larger pump may be required. Consult the factory if in doubt.
6. Install a pipe in the tank drain fitting that goes to a floor sink, and install a drain valve. If a floor sink is not available, install a hose bib.
7. Hot water tanks in an existing installation are likely to have a deposit of silt on the bottom. Therefore, it is important to extend the pump suction pipe in the tank to a position near the top. Pipe the return from the heater to the bottom of the tank.

**2K. Two-Temperature System**

See Figures 16 and 17 for piping schematics. This system is designed to maintain the tempered water circulating loop at the desired temperature during idle periods as well as when there is a demand for hot water. It is recommended for general purpose water supply including shower and bathing applications. Water at 180°F is available directly from the tank.

**SECTION 3. Operation**

**3A. Controls - General**

1. Electronic Ignition Controls:
  - a. Intermittent Ignition:  
Pilots are automatically lit when the operating aquastat calls for heat (System #9 and #4)  
The unit performs its own safety check and opens the main valves only after the pilot is



proven to be lit. Whenever the pilot flame is interrupted, the main gas valve closes within 0.8 seconds.

- b. Electronically Supervised Standing Pilot System (System #16):

When pilot flame fails, the ignition control module responds in less than 0.8 seconds and provides 100% safety shutdown.

2. Operating Controls:

- a. Electrically Operating Controls:

Single, two-stage, four-stage or modulating aquastats are provided in models VW, PW and IW heaters to control the desired service water temperature. The temperature sensing bulb is located in the heater inlet.

- b. Modu-snap Valves:

These valves are furnished in addition to the main electric gas valve when heater is ordered with mechanical modulation. Each valve has a remote capillary bulb immersed in a well at the outlet header to maintain a constant outlet temperature. Consult Table 5 for desired temperature setting.

3. High Limit Controls:

The manual reset high limit switches are provided as standard equipment on all heaters. Automatic reset switches are optionally

Dial No.	1	2	3	4	5	6	7	8	9+
Temp °F	120	128	135	143	150	158	165	173	180+

**Table 5. Modu-Snap Temperature Settings.**

provided. The temperature sensing bulb of the switch is always located in the heater outlet. Burners will automatically shut down whenever overheating of water occurs.

- 4. Flow Switch:

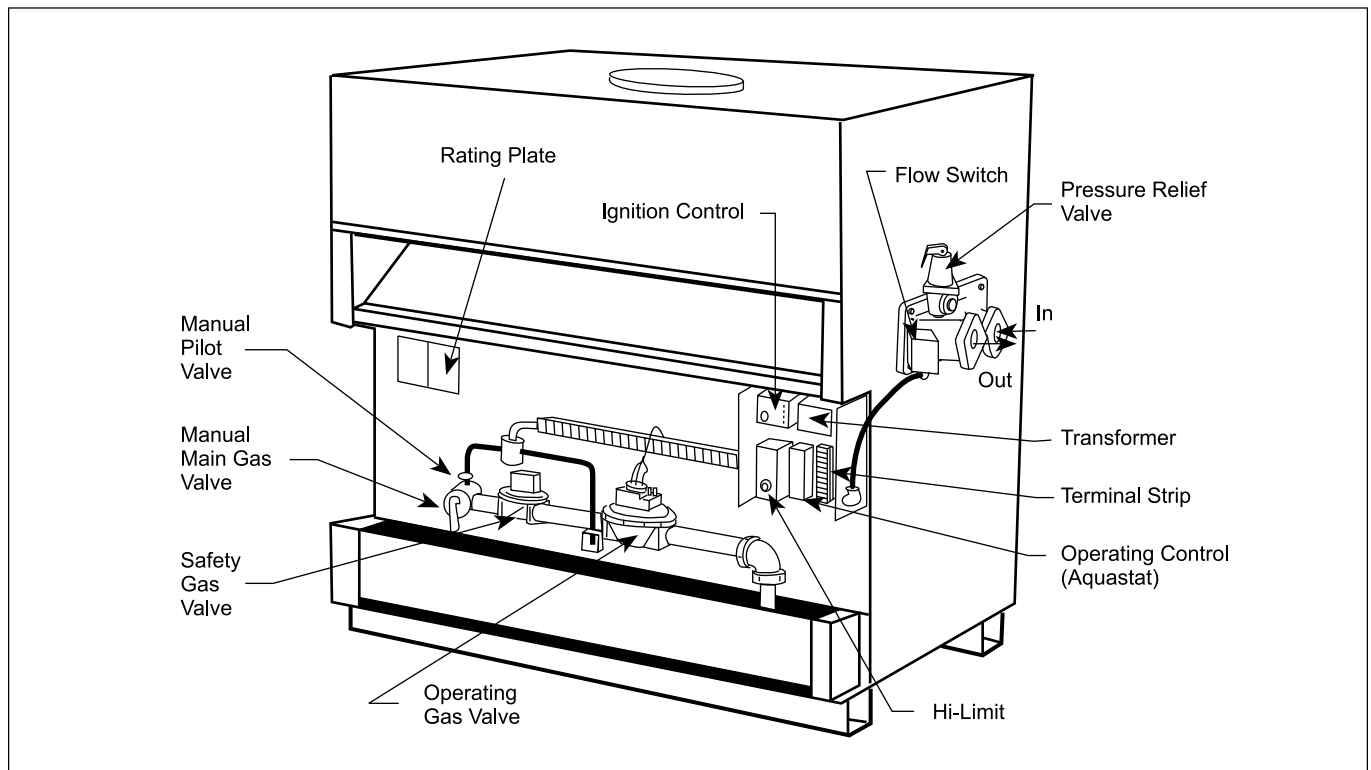
Standard on all models: Models VW and PW, the switch is mounted in the outlet "tee" connection. Model IW, the switch is mounted directly in the header outlet. The flow switch shuts down all burners in case of low water condition or pump failure.

- 5. Low Water Cut Off:

The low water cut off automatically shuts off heater whenever water level drops below probe. Located at heater inlet (model IW and PW) and at return header (model VW).

**3B. Initial Start-Up**

Before placing the heater in operation, be certain that the heater is filled with water and all air is purged from the system. Once the heater is connected to the



**Figure 18. Single Installation Piping Diagram, Model IW.**

gas supply, the automatic safety shutoff devices must be checked.

1. Before beginning the tests, make sure the main manual gas valve, and any other heater firing valves are in the "OFF" position.
2. Make sure the heater's power switch is in the "ON" position. After placing the manual pilot gas valve in the open position and resetting all safety devices, (high limit, pressure switch, low-water cutoff, etc.) pilot(s) can be lit following the procedure located on the heater rating plate.
3. Once the pilot(s) is lit and has been established for five minutes, the flame failure response time should be checked as follows:

**Systems 9 and 4 - (Intermittent ignition):** With this system pilots are automatically lit when the operating controls call for heat. If the pilot flame fails for any reason, the main valve is shut off within one second and the pilot spark ignition is initiated until the pilot flame has been reestablished. On propane systems, unit locks out for safety. This sequence should be checked by turning off the manual pilot gas valve, and, at the same time, monitoring the audible sparking at the pilot burner and signal interruption to the main valve.

### ⚠ Caution

Propane gas is heavier than air and sinks to the ground. Exercise extreme care in lighting the heater when so equipped.

**System 16 - (Electronically supervised standing pilot system):** Extinguish the pilot flame by placing the manual pilot valve in the closed position, and at the same time, begin recording the time it takes for the output signal from the electronic ignition control to be interrupted. The signal interruption can be detected either with a test light or a voltmeter. The response time should never exceed one second.

4. With the pilots lit, initial activation of the main burners can be achieved by slowly opening the main manual valve. The result should be a smooth lighting of the main burners.

### Hi-Limit Checkout:

After running the heater for a long enough period, bring the water temperature within the range of the hi-limit and slowly back off the high limit setting until the heater shuts off. The main burners should reignite when the hi-limit is reset and turned back up to its original setting. The heater should now run until it shuts off automatically on operating aquastat.

## 3C. To Start Up System:

### 1. Start Up Boiler

Be certain system pump is running, then proceed as follows:

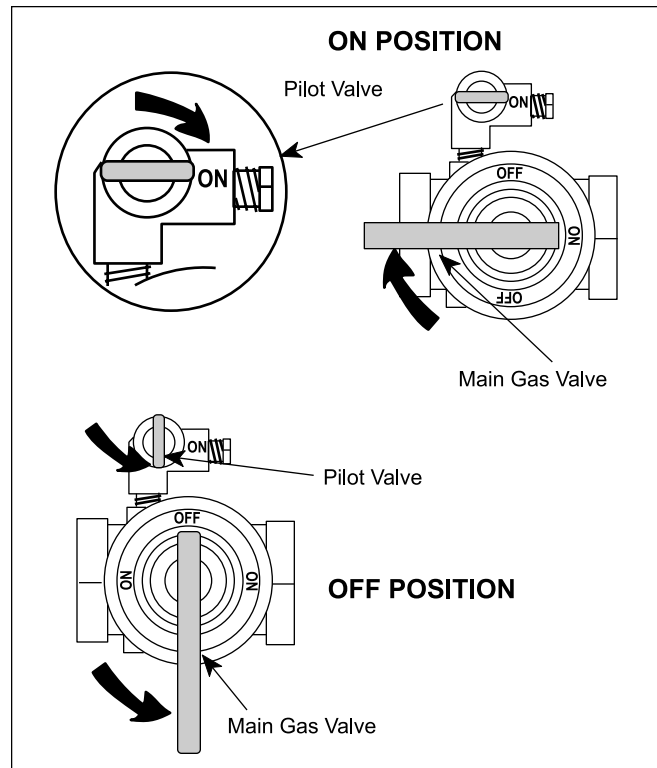


Figure 19. Gas Manual Valves.

- a. Turn off main electrical switch.
- b. Turn off all manual gas valves and wait five minutes (see Figure 19).
- c. Set operating control to lowest setting.
- d. Slowly turn manual gas valve to "ON".
- e. Reset all safety valve switches (manual reset high limit and low water cut off).
- f. Open manual pilot valve. Turn on main electrical switch.
- g. Set temperature controller to desired temperature. Pilot will light automatically to ignite main burners whenever the aquastat calls for heat.

For standing pilot system, press on pilot relay knob, see Figure 20, light pilot and keep relay knob

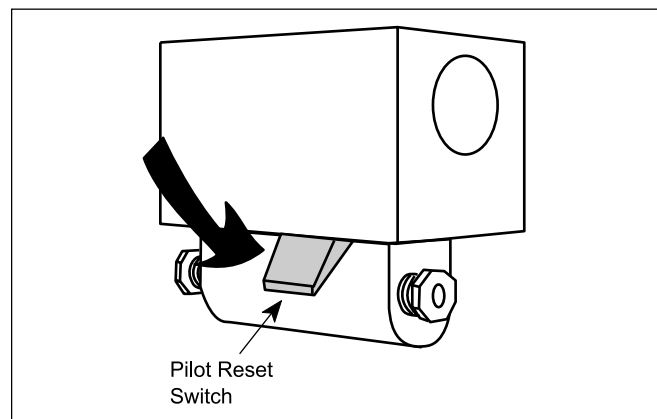


Figure 20. Pilot Safety Relay.

depressed for one minute then release. Once the pilot is lit, the power is supplied through the aquastat to the main gas valve.

## 2. To set the temperature and high-limit controls:

### When using a tank aquastat:

Set the tank aquastat to the desired tank temperature. Set the heater temperature control 20°F higher than tank aquastat. Set the manual reset high limit 50°F higher than tank aquastat. Example: If desired temperature is 140°F, set the tank aquastat at 140°F, set the heater temperature control at 160°F, and set the manual reset high limit at 190°F. If the heater is equipped with a pump time delay, the three-position switch on the side of the heater can be put into the "Auto Pump" position, so that the pump will only run when the tank aquastat calls for heat. Then, when the call for heat is satisfied, the heater will turn off, but the pump will run for the set amount of delay time (adjustable between 0.1 and 10 minutes).

### When a tank aquastat is not used:

The pump on the heater must run continuously, so the heater's temperature control will sense the tank's water temperature. Set the heater temperature control to the desired tank temperature. Set the manual reset high limit 50°F higher than the heater temperature control. Example: If desired temperature is 140°F, set the heater temperature control at 140°F, and set the manual reset high limit at 190°F.

## 3D. To Turn Off Heater:

1. Turn off main electric switch.
2. Close all manual gas valves.

## 3E. To Shut Down System:

To shut down heater, turn off all manual gas valves and electrical disconnect switches. Whenever danger of freezing exists, shut off water supply and remove drain plug in the bottom of front header cover. Drain every part of system subject to freezing temperature.

## SECTION 4. Maintenance

1. Lubricate the water circulating pump (see instructions found on the pump).
2. If a strainer is employed in a pressure reducing valve or in piping, clean it every six (6) months.
3. At start-up and every six (6) months thereafter, the pilot and main burner flame should be observed for proper performance (see Figure 21). See attached lighting and shut-down instructions for proper pilot flame pattern). If flame has the

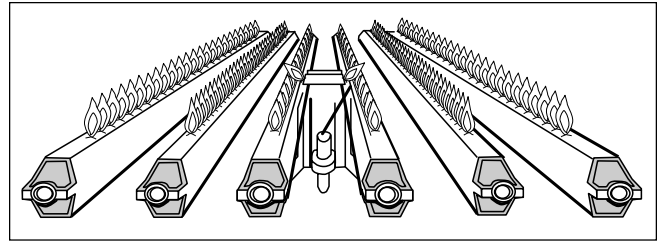


Figure 21. Main Burner Flame Pattern.

appearance of "sooting" tips, check for debris near orifices. Call serviceman.

4. Inspect the venting system for obstruction, leakage and corrosion at least once each year.
5. Keep heater area clear and free from combustible material, gasoline and other flammable vapors and liquids (see Table 1 for minimum clearances).
6. Be certain all combustion air and ventilation openings are unobstructed.
7. Check for fouling on the external surfaces of the heat exchanger every six months. (**NOTE:** After installation and first start-up, check the heat exchanger for fouling after the following periods of operation: 24 hours, 7 days, 30 days, 90 days, and once every six months thereafter).

Fouling on the external surfaces of the heat exchanger is caused by incomplete combustion and is a sign of combustion air and/or venting problems. As soon as any fouling is observed, the cause of the fouling should be corrected (see Section 5, Troubleshooting Guide). The heat exchanger can be checked by locating a mirror under the burners with a flashlight. An alternate method is to remove the venting and top panel as necessary to inspect from above. Also check the vent system for defects at this time.

- a. If cleaning is required, shut off all electrical and gas supply to the heater.
- b. To expose the heat exchanger:

### **Indoor Models:**

Remove flue pipe, top of unit, rear upper jacket, flue collector rear panel and heat exchanger baffles.

### **Outdoor Models:**

Remove vent top assembly, rear upper jacket, flue collector rear panel and heat exchanger baffles.

### c. Remove all burners:

It is usually more convenient to remove the burner tray assembly. Disconnect sensor wire, ignition cable (or thermocouple generator) and pilot gas line. Disconnect manifold inlet union(s). Remove the four (4) retaining screws. Grasp burner/pilot assembly firmly at the front. Push it back, disengaging it from the gas orifice.

Lower the front of the burner (to avoid damaging pilot shield) then remove the burner tray.

**⚠ Caution**

Black carbon or green soot on a dirty heat exchanger can, under certain conditions, be ignited by a random spark or open flame. To prevent this unlikely occurrence, dampen the soot deposits with wet brush or fine water spray before servicing or cleaning the heat exchanger.

With a wire brush, remove soot and loose scale from heat exchanger. Clean fallen debris from bottom of heater. Make sure burner ports are clear and pilot assembly is free of debris.

- d. Reassemble in reverse order:  
Be sure the heat exchanger baffles are replaced.
- 8. The gas and electric controls installed on heaters are engineered for both dependable operation and long life, but the safety of this equipment completely depends on their proper functioning. It is strongly recommended that the basic items be checked by a competent serviceman every year and replaced when necessary. The basic controls are:
  - a. Water temperature controls.
  - b. Pilot safety system.
  - c. Automatic electric gas valve(s).
  - d. Flow sensing safety device.
- 9. Low water cutoffs should be inspected every six (6) months, including flushing of float types.

**NOTE:** Warranty does not cover any damage caused by lack of required maintenance or improper operating practices.

- 10. Both modulating and stage valve are adjusted at the factory for minimum permissible rates and should not be readjusted.

**SECTION 5.  
Troubleshooting and Analysis of  
Service Problems**

- 1. For proper service and problem diagnosis of the heater and heater system, the following tools are required:
  - a. Gas pressure test kit with range from zero to 14 W.C. Either a slack tub manometer or an accurate gas pressure gauge is acceptable with proper adapters which will connect to the available fittings in the line and on the gas valve.

- b. Multi-meter with the following ranges:  
0 to 500 volts A.C.  
0 to 1000 ohms continuity.
  - c. Tube cleaning kit consisting of reamer, stainless steel brush, speed handle and handle extensions.
  - d. Heater thermometer (with 1/2" NPT well) 100-240°F.
- 2. In addition, the heater should be equipped with a system pressure gauge with proper ranges for heater operation.

**I. HEATER WILL NOT FIRE.**

Possible Cause	What To Do
A. Electric power is off	A. Check to see that main power switch is "ON." Use testing device to trace power to heater junction box.
B. Operating or safety control has opened circuit to electric gas valve.	B. Turn off power. Use continuity across terminals of each operating and safety control switch up to the electric gas valve. Replace effective control.
C. Pilot flame is out.	C. Relight pilot per instruction.
D. Manual reset device has tripped.	D. Follow instructions for start-up. Reset Pilot safety and all manual reset safety switches and reset manual safety gas valve.
E. No gas pressure to burners.	E. Trace gas line to service shutoff cock. If service cock is open, trace gas line to meter. If no pressure is present at meter, call for public utility service. If gas is present in heater inlet, check pressures in following sequence: (1) downstream from pressure regulator. (2) downstream from electric gas valve. Replace or adjust as necessary.
F. Electric gas valve operator is burned out or shortened.	F. Disconnect wiring harness at gas valve terminals. Check continuity to actuator coil. If open circuit or short is indicated, replace coil or operator.

**II. HEATER IS POUNDING, KNOCKING OR EMITTING STEAM FROM RELIEF VALVES.**

Possible Cause	What To Do
A. Low or no water flow.	A. This condition is usually caused by lack of adequate water flow through heater. Check the following: 1. Is the heater wired into the pump circuit so that the heater cannot fire unless the pump is running? 2. Check to see that all valves in system are open to be sure that water can circulate through the heater and the system. 3. If the system has automatic water valves (2-way or 3-way) that can cut off the water flow through the heater check to see that they are equipped with end-switches which shut the heater down when the water flow through the heater is reduced by 70% from full flow. 4. Examine pump for clogged impeller.
B. Low or no system pressure.	B. Clean strainer in pressure reducing valve. Look for closed valve water line or a leak in the system.
C. Clogged "Y" strainer.	C. Remove strainer element and clean screen.
D. Debris from system piping is blocking tubes.	D. Remove header covers. Examine all tubes and waterways. Use new gaskets when reassembling. Clean out tubes.
E. Scale has formed in tubes.	E. This is always caused by the inflow of raw water into the system. Clean tubes with tube cleaning kit. Determine hardness. Check water flow, replace pump for modified flow if necessary.

**III. WATER DRIPPING IN FIREBOX.**

Possible Cause	What To Do
Tube in heat exchanger has overheated and ruptured.	A tube failure is almost always caused by (a) scale formation in the tube or (b) inadequate water flow through the boiler.

**IV. PRESSURE RELIEF VALVES LEAKING INTERMITTENTLY OR STEADILY.**

Possible Cause	What To Do
A. Static pressure in system exceeds setting of relief valve.	A. Calculate height of water in system above heater. Install new valve with psi setting 25% above required static system working pressure. Do not exceed 160 psi.
B. Expansion tank is water-logged (if installed).	B. Drain expansion tank, then reopen it to the system. Look for leaks in expansion tank or fittings. Calculate required volume of expansion tank in relation to system to determine if tank is adequate.

**V. SOOT IN FLUEWAYS OR IN TUBES, OR NOXIOUS FUMES INDICATIVE OF BAD COMBUSTION.**

Possible Cause	What To Do
A. Combustion air supply to heater room is inadequate.	A. Check air supply opening. Look for debris in screen or louver which covers combustion air opening, or for material blocking the opening.
B. Stack or vent is blocked or restrictive.	B. Look for blocked stack and excessive number of elbows in stack or excessive length of horizontal runs.
C. Severe down draft is causing spillage of flue products into room.	C. Check for (1) proper vent cap on stack; (2) adequate height of stack above roof; (3) equipment exhausting air from inside of building; and (4) proper installation of draft diverter.
D. Gas pressure to burners is excessive.	D. Check gas pressure with nanometer, and adjust with heater firing at full rate.
E. Heater not fitted for the fuel supplied.	E. See nameplate for correct fuel.
F. Heater installed at high altitude without proper derating.	F. Installations at altitudes in excess of 2000 ft. above sea level are subject to jurisdiction of the local inspection authorities.

## SECTION 6. Parts Descriptions and Order Numbers

Key Description No	Model 500	Model 600	Model 715	Model 850	Model 1010	Model 1200	Model 1430	Model 1670	Model 1825
1 Top Panel Assembly	10535701	10535702	10535703	10535704	10535705	10535706	10535707	10535708	10535709
2 Spacer, Flue Collector	—	—	—	10540800	10540800	10540800	10540800	10540800	10540800
3 End Panel, Flue Collector (left)	10533700	10533700	10533700	10533700	10533700	10533700	10533700	10533700	10533700
4 End Panel, Flue Collector (right)	10533800	10533800	10533800	10533800	10533800	10533800	10533800	10533800	10533800
5 Rear Panel, Flue Collector	10535501	10535502	10535503	10535504	10535505	10535506	10535507	10535508	10535509
6 Rear Panel, Ext., Flue Collector	Not Required								
7 Front Support, Flue Collector	10534401	10534402	10534403	10534404	10534405	10534406	10534407	10534408	10534409
8 Tile Cover, Front & Rear	10534201	10534202	10534203	10534204	10534205	10534206	10534207	10534208	10534209
9 Baffle, Heat Exch. (Ft & Rear)	10534301	10534302	10534303	10534304	10534305	10534306	10534307	10534308	10534309
10,11 Baffle, Heat Exchanger	10534601	10534602	10534603	10534604	10534605	10534606	10534607	10534608	10534601
	(7)	(14)	(14)	(14)	(14)	(28)	(28)	(28)	(14)
	—	—	—	—	—	—	—	—	10534602
	—	—	—	—	—	—	—	—	(14)
12 Return Header (S-00981)	10364300	10364300	10364300	10364300	10364300	10364300	10364300	10364300	10364300
Return Header (S00642)									
Bronze	10364301	10364301	10364301	10364301	10364301	10364301	10364301	10364301	10364301
13 Inlet/Outlet Header (S-00943)	10364500	10364500	10364500	10364500	10364500	10364500	10364500	10364500	10364500
Inlet/Outlet Header (S00640)	10364501	10364501	10364501	10364501	10364501	10364501	10364501	10364501	10364501
Bronze									
14 Flange, 2" (S00636)	10391302	10391302	10391302	10391302	—	—	—	—	—
Flange, 2 1/2" (S00635)	—	—	—	—	10391303	10391303	10391303	10391303	10391303
Flange, 2 1/2" (S00644), Bronze	10391304	10391304	10391304	10391304	10391304	10391304	10391304	10391304	10391304
15 Flange Gasket	S0063700	S0063700	S0063700	S0063700	S0063700	S0063700	S0063700	S0063700	S0063700
16 Header Gasket w/Barrier	S0095100	S0095100	S0095100	S0095100	S0095100	S0095100	S0095100	S0095100	S0095100
17 Header Gasket	Use S00951 00-Cut Out Barrier								
18 Baffle, Water Inlet	10338300	10338300	10338300	10338300	10338300	10338300	10338300	10338300	10338300
19 Barrier, Water	10397500	10397500	10397500	10397500	10397500	10397500	10397500	10397500	10397500
20 Well, Aquastat	E0025900	E0025900	E0025900	E0025900	E0025900	E0025900	E0025900	E0025900	E0025900
Well, Aquastat F/4 Stage	E0085700	E0085700	E0085700	E0085700	E0085700	E0085700	E0085700	E0085700	E0085700

NOTE: Numbers in ( ) represent quantity required for each size. Quantity is one otherwise.

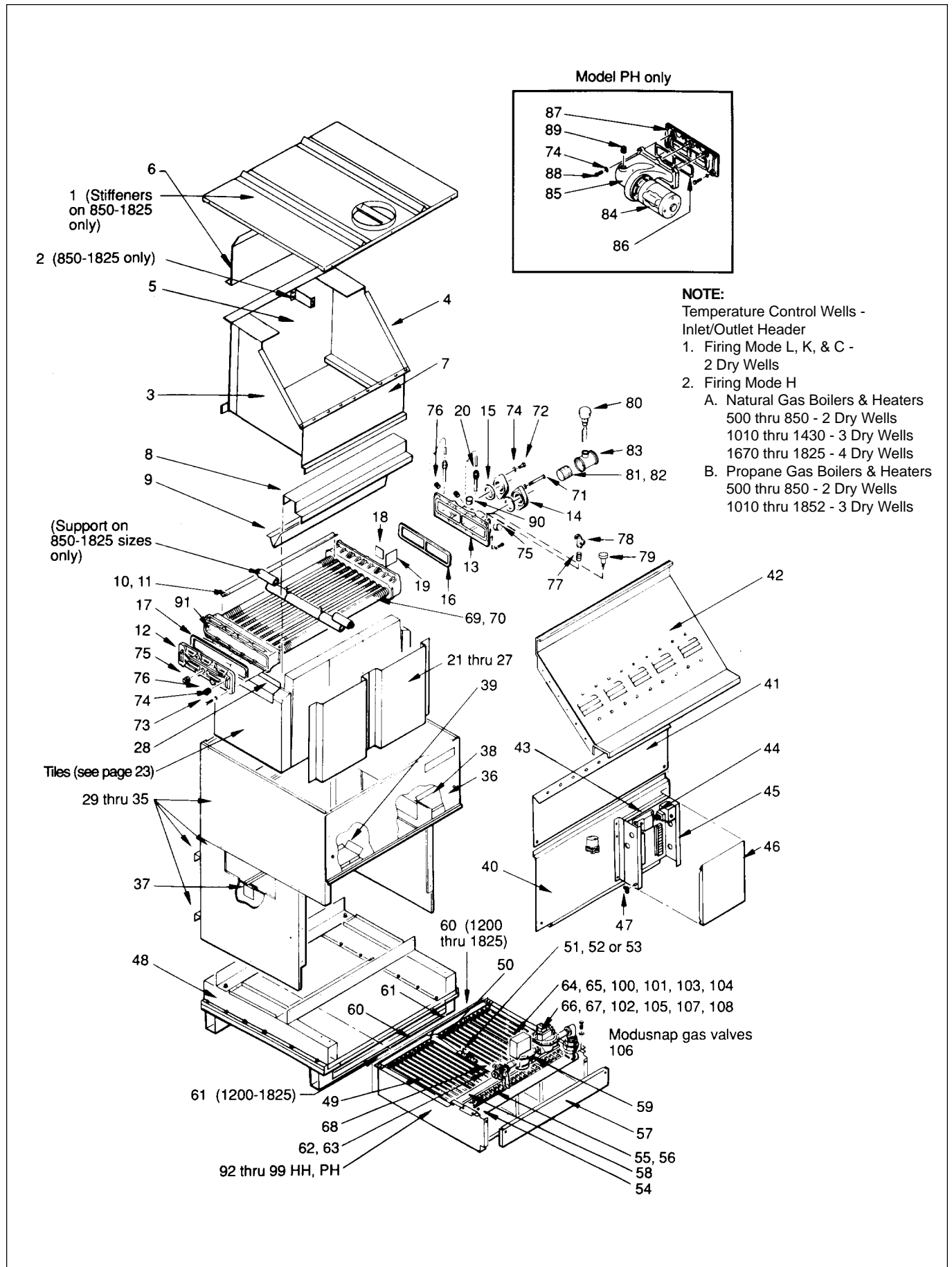
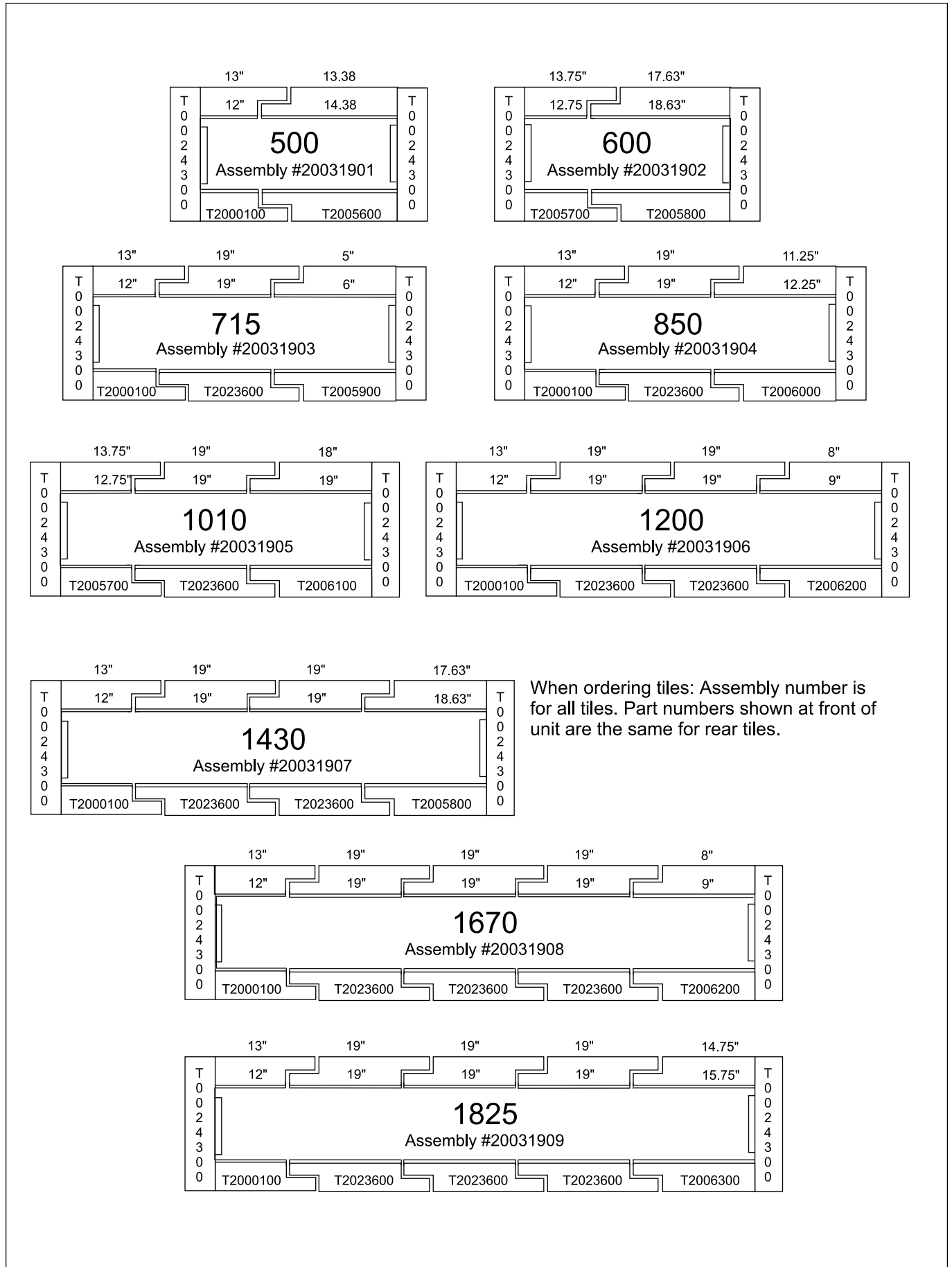


Figure 22. Parts Identification.

Key No	Description	Model 500	Model 600	Model 715	Model 850	Model 1010	Model 1200	Model 1430	Model 1670	Model 1825
21	Tile, Heat Shield/Sprr, Frt. & Rr.	10560100 (2)	—	—	—	—	—	—	—	—
22	Tile, Heat Shield/Spacer, Front	—	10547901	10547902	—	—	10547903	10547901	10547904	10547903
23	Tile, Heat Shield/Spacer, Front	—	—	—	10548002	10548003	—	—	—	10548001
24	Tile, Heat Shield/Spacer, Front	—	—	—	—	—	10548101	10548102	10548103	10548104
25	Tile, Heat Shield/Spacer, Rear	—	10548201	10548202	—	—	10548203	10548201	10548204	10548203
26	Tile, Heat Shield/Spacer, Rear	—	—	—	10548302	10548303	—	—	—	10548301
27	Tile, Heat Shield/Spacer, Rear	—	—	—	—	—	10548401	10548402	10548403	10548404
28	Saddle Assembly, End Tile	10533600 (2)	10533600 (2)	10533600 (2)	10533600 (2)	10533600 (2)	10533600 (2)	10533600 (2)	10533600 (2)	10533600 (2)
29	Lower End Panel/Heat Shield Weldment, Right	10540701	10540701	10540701	10540701	10540701	10540701	10540701	10540701	10540701
30	Lower End Panel/Heat Shield Weldment, Left	10540702	10540702	10540702	10540702	10540702	10540702	10540702	10540702	10540702
31	Lower Rear Panel & Baffle Rear Weldment	10532901	10532902	10532903	10532904	10532905	10532906	10532907	10532908	10532909
32	Middle Rear Panel/Heat Shield Weldment	10540401	10540402	10540403	10540404	10540405	10540406	10540407	10540408	10540409
33	End Panel, Upper Right	10531600	10531600	10531600	10531600	10531600	10531600	10531600	10531600	10531600
34	End Panel, Upper Left	10534000	10534000	10534000	10534000	10534000	10534000	10534000	10534000	10534000
35	Upper Rear Panel/Heat Shield Weldment	10540501	10540502	10540503	10540504	10540505	10540506	10540507	10540508	10540509
36	Front Panel, Upper	10531501	10531502	10531503	10531504	10531505	10531506	10531507	10531508	10531809
37	Brackets, Support, End Tile	10551000 (2)	10551000 (2)	10551000 (2)	10551000 (2)	10551000 (2)	10551000 (2)	10551000 (2)	10551000 (2)	10551000 (2)
38	Drafthood, Relief Baffle, Right	10540901	10540902	10540903	10540904	10540905	10540906	10540907	10540908	10540909
39	Drafthood, Relief Baffle, Left	10541001	10541002	10541003	10541004	10541005	10541006	10541007	10541008	10541009
40	Lower Right Panel/Heat Shield Weldment	10554601	10554602	10554603	10554604	10554605	10554606	10554607	10554608	10554609
41	Middle Front Panel	10554401	10554402	10554403	10554404	10554405	10554406	10554407	10554408	10554409
42	Sweep Sheet, Flue Collector	10533901	10533902	10533903	10533904	10533905	10533906	10533907	10533908	10533909

NOTE: Numbers in ( ) represent quantity required for each size. Quantity is one otherwise.





**Figure 23. Tile Assemblies.**

Key No	Description	Model 500	Model 600	Model 715	Model 850	Model 1010	Model 1200	Model 1430	Model 1670	Model 1825
43	Ignition Control, Electronic	E0100900	E0100900	E0100900	E0100900	E0100900	E0100900	E0100900	E0100900	E0100900
44	Transformer, 11 5V/24V	E0086100	E0086100	E0086100	E0086100	E0086100	E0086100	E0086100	E0086100	E0086100
45	Control Box Weldment	10545800	10545800	10545800	10545800	10545800	10545800	10545800	10545800	10545800
46	Control Box Cover	10547200	10547200	10547200	10547200	10547200	10547200	10547200	10547200	10547200
47	Wing Nut, #8-32	F0032100 (2)	F0032100 (2)	F0032100 (2)	F0032100 (2)	F0032100 (2)	F0032100 (2)	F0032100 (2)	F0032100 (2)	F0032100 (2)
48	Base Tile Support Assy.	10536901	10536902	10536903	10536904	10536905	10536906	10536907	10536908	10536909
49	Burner, Main	L0052300	L0052300	L0052300	L0052300	L0052300	L0052300	L0052300	L0052300	L0052300
50	Pilot Brkt/Burner Weldment (Johnson Pilot)	10529501	10529501	10529501	10529501	10529501	10529501	10529501	10529501	10529501
	(Honeywell Pilot)	10529502	10529502	10529502	10529502	10529502	10529502	10529502	10529502	10529502
51	Pilot Burner (Johnson)	W0034700	W0034700	W0034700	W0034700	W0034700	W0034700	W0034700	W0034700	W0034700
	Standing Pilot, Nat	W0035800	W0035800	W0035800	W0035800	W0035800	W0035800	W0035800	W0035800	W0035800
	Pilot Burner (Honeywell)	W0034600	W0034600	W0034600	W0034600	W0034600	W0034600	W0034600	W0034600	W0034600
	Standing Pilot, Nat	W0034400	W0034400	W0034400	W0034400	W0034400	W0034400	W0034400	W0034400	W0034400
52	Pilot Burner (Johnson)	W0034500	W0034500	W0034500	W0034500	W0034500	W0034500	W0034500	W0034500	W0034500
	Standing Pilot, Propane	W0034300	W0034300	W0034300	W0034300	W0034300	W0034300	W0034300	W0034300	W0034300
	Pilot Burner (Honeywell)	10525901	10525902	10525903	10525904	10525905	10525906	10525907	10525908	10525909
	Standing Pilot, Propane	L0050700 (22)	L0050700 (26)	L0050700 (30)	L0050700 (36)	L0050700 (42)	L0050700 (50)	L0050700 (60)	L0050700 (70)	L0050700 (76)
	Standing Pilot, Propane	L0032900 (22)	L0032900 (26)	L0032900 (30)	L0032900 (36)	L0032900 (42)	L0032900 (50)	L0032900 (60)	L0032900 (70)	L0032900 (76)
53	Pilot Burner (Johnson)	10552901	10552902	10552903	10552904	10552905	10552906	10552907	10552908	10552909
	IID Pilot, Nat	10525301	10525302	10525303	10525304	10525305	10525306	10525307	10525308	10525309
	Pilot Burner (Honeywell)	10542701	10542702	10542703	10542704	10542705	10542706	10542707	10542708	10542709
	IID Pilot, Nat	10525701	10525702	10525703	10525704	10525705	10525702 (2)	10525703 (2)	10525704 (2)	10525704 (2)
54	Gas Manifold Weldment (single)	10542001	10542002	10542003	10542004	10542005	10542002	10542003	10525704	10525704
55	Orifice, Nat, Gas	V0004200	V0004200	V0004200	V0004200	V0004300	V0004300	V0004300	V0004300	V0004300
56	Orifice, Propane - 9" W.C.	V0004800	V0004800	V0004800	V0004800	V0004200	V0004200	V0004300	V0004300	V0004300
57	Manifold Cover Plat Assy.									
58	Burner, Anti Rotation Brkt (left)									
59	Burner, Anti Rotation Brkt (right)									
60	Burner Tie Down Bracket (left)									
61	Burner Tie Down Bracket (right)									
62	Valve, Manual, Gas, Natural									
63	Valve, Manual, Gas, Propane									

NOTE: Numbers in ( ) represent quantity required for each size. Quantity is one otherwise.

Key No	Description	Model 500	Model 600	Model 715	Model 850	Model 1010	Model 1200	Model 1430	Model 1670	Model 1825
64	Safety Gas Valve, On-Off, Two Stage (Nat)	V0046600	V0046600	V004600	V004600	V0046700	V0046700	V0046700	V0046700	V0046800
65	Safety Gas Valve, On-Off, Two Stage (Pro)	V0046600	V0046600	V0046600	V0046600	V0046600	V0046600	V0046700	V0046700	V0046700
66	Valve, Gas, Operating / Reg. On-Off, Two Stage (Nat)	V0051200	V0051200	V0051200	V0051200	V0051300	V0051300	V0051300	V0051400	V0051400
67	Valve, Gas, Operating / On-Off Two Stage (Pro)	V0054800	V0054800	V0054800	V0054800	V0054800	V0054800	V0054900	V0054900	V0054900
68	Valve, Pilot, Gas, Manual	W0002100	W0002100	W0002100	W0002100	W0002100	W0002100	W0002100	W0002100	W0002100
69	Tube Assembly, Copper	10534701	10534702	10534703	10534704	10534705	10534706	10534707	10534708	10534709
70	Tube Assembly, Cupro-nickel	10553701	10553702	10553703	10553704	10553705	10553706	10553707	10553708	10553709
71	Screw, Cap, 1/2" - 13 x 4 1/2"	F0028700	F0028700	F0028700	F0028700	F0028700	F0028700	F0028700	F0028700	F0028700
72	Screw, Cap, 1/2" - 13 x 2 1/4"	F0023100	F0023100	F0023100	F0023100	F0023100	F0023100	F0023100	F0023100	F0023100
73	Screw, Cap, 1/2" - 13 x 1 1/2"	F0013300	F0013300	F0013300	F0013300	F0013300	F0013300	F0013300	F0013300	F0013300
74	Washer	F0011400	F0011400	F0011400	F0011400	F0011400	F0011400	F0011400	F0011400	F0011400
75	Plug, Sq. Hd., 1 "NPT	P0033000	P0033000	P0033000	P0033000	P0033000	P0033000	P0033000	P0033000	P0033000
76	Plug, 1/2" NPT	P0026900	P0026900	P0026900	P0026900	P0026900	P0026900	P0026900	P0026900	P0026900
77	Nipple, Brass, 3/4" x 2"	P0025300	P0025300	P0025300	P0025300	P0025300	P0025300	P0025300	P0025300	P0025300
78	Valve, Press, Relief 3/4" -75 PSI	A0063600	A0063600	A0063600	A0063600	A0063600	A0063600	A0063600	A0063600	A0063600
79	Temp/Press Gauge	A0079000	A0079000	A0079000	A0079000	A0079000	A0079000	A0079000	A0079000	A0079000
80	Flow Switch (indoor) (outdoor)	E0013100	E0013100	E0013100	E0013100	E0013100	E0013100	E0013100	E0013100	E0013100
81	Nipple, 2" x cl. - Galv	E0013000	E0013000	E0013000	E0013000	E0013000	E0013000	E0013000	E0013000	E0013000
82	Nipple, 2 1/2" x 3" Galv	P0038500	P0038500	P0038500	P0038500	_____	_____	_____	_____	_____
83	Red. Tee, 2 x 2 x 1, Galv	_____	_____	_____	_____	P0022000	P0022000	P0022000	P0022000	P0022000
	Red. Tee, 2 1/2 x 2 1/2 x 1, Galv	P0028500	P0028500	P0028500	P0028500	_____	_____	_____	_____	_____
84	Pump Rotating Assembly	_____	_____	_____	_____	P0055900	P0055900	P0055900	P0055900	P0055900
85	Pump Housing	10261501	10261501	10261501	10261501	10261501	10261501	10261501	10261501	10261501
86	Gasket, Pump Housing	S0024600	S0024600	S0024600	S0024600	S0024600	S0024600	S0024600	S0024600	S0024600
87	Pump Adapter	10364200	10364200	10364200	10364200	10364200	10364200	10364200	10364200	10364200
88	Screw, Hex Hd. 1/2 - 13 x 1 3/4	F0009200	F0009200	F0009200	F0009200	F0009200	F0009200	F0009200	F0009200	F0009200

See Current Document 2040 For Pump Requirements

NOTE: Numbers in ( ) represent quantity required for each size. Quantity is one otherwise.

Key No	Description	Model 500	Model 600	Model 715	Model 850	Model 1010	Model 1200	Model 1430	Model 1670	Model 1825
89	Plug, 3/4, Sq. Hd.	P0027000	P0027000	P0027000	P0027000	P0027000	P0027000	P0027000	P0027000	P0027000
90	Pipe Extension 1/2" Female 1/2" Male									
91	Baffle, Diffuser	P0072300	P0072300	P0072300	P0072300	P0072300	P0072300	P0072300	P0072300	P0072300
92	Burner Tray, IID, 2 Stage, SGL Sect. Manifold (Nat)	10338400	10338400	10338400	10338400	10338400	10338400	10338400	10338400	10338400
93	Burner Tray, St. Pilot, 2 Stage, SGL, Sect. Manifold (Pro)	10550601	10550602	10550603	10550604	10550605	10550606	10550607	10550608	10550609
94	Burner Tray, I I D, 4 Stage, Split Manifold (Nat)	10529601	10529602	10529603	10529604	10529605	10529606	10529607	10529608	10529609
95	Burner Tray, St. Pilot, 4 Stage, Split Manifold (Pro)	10550701	10550702	10550703	10550704	10550705	10550706	10550707	10550708	10550709
96	Burner Tray, IID, Mech. Mod. Split Manifold (Nat)	10550301	10550302	10550303	10550304	10550305	10550306	10330307	10330508	10330509
97	Burner Tray, I I D, Mech. Mod., 3 & 4 Sect. Manifold (Nat)	10550701	10550702	10550703	10550704	10550705	10550706	10550707	10550708	10550709
98	Burner Tray, St. Pl. Mech. Mod. Splt. Manifold (Pro)	10550301	10550302	10550303	10550304	10550305	10550306	10550307	10550308	10550309
99	Burner Tray, St. Pl., Mech. Mod., 3 Sect. Manifold (Pro)	10550701	10550702	10550703	10550704	10550705	10550706	10550707	10550708	10550709
100	Combination Gas Valve, 4 Stage, (Nat)	V0059600 (2)	V0059600 (2)	V0059600 (2)	V0070400 (2)	V0070400 (2)	V0070400 (2)	V0070400 (2)	V0070400 (2)	V0070400 (2)
101	Safety Gas Valve, 4 Stage (Nat)									
102	Operating/Reg. Gas Valve, 4 Stage (Nat)									
103	Combination Gas Valve, 4 Stage, (Pro)	V0070800 (2)	V0070800 (2)	V0070800 (2)	V0070900 (2)	V0070900 (2)	V0070900 (2)	V0070900 (2)	V0070900 (2)	V0070900 (2)
104	Safety Gas Valve, 4 Stage, (Pro)									
105	Operating/Reg. Gas Valve, 4 Stage (Pro)									
106	Modusnap Gas Valve, (HH &PH Only), Mech. Mod. (Nat & Pro)	V0045100 V0071100	V0045100 V0071100	V0045100 V0071100	V0045100 V0071100	V0045100 V0071100	V0045100 V0071100	V0045100 V0071100	V0045100 V0071100	V0045100 V0071100
107	Operating/Reg. Gas Valve, Mech. Mod. (Nat)	V0047600	V0047600	V0047600	V0047600	V0047600	V0047600	V0047600	V0047600	V0047600
108	Operating/Reg. Gas Valve, Mech. Mod. (Pro)	V0054800	V0054800	V0054800	V0054800	V0054800	V0054800	V0054800	V0054800	V0054800

NOTE: Numbers in ( ) represent quantity required for each size. Quantity is one otherwise.

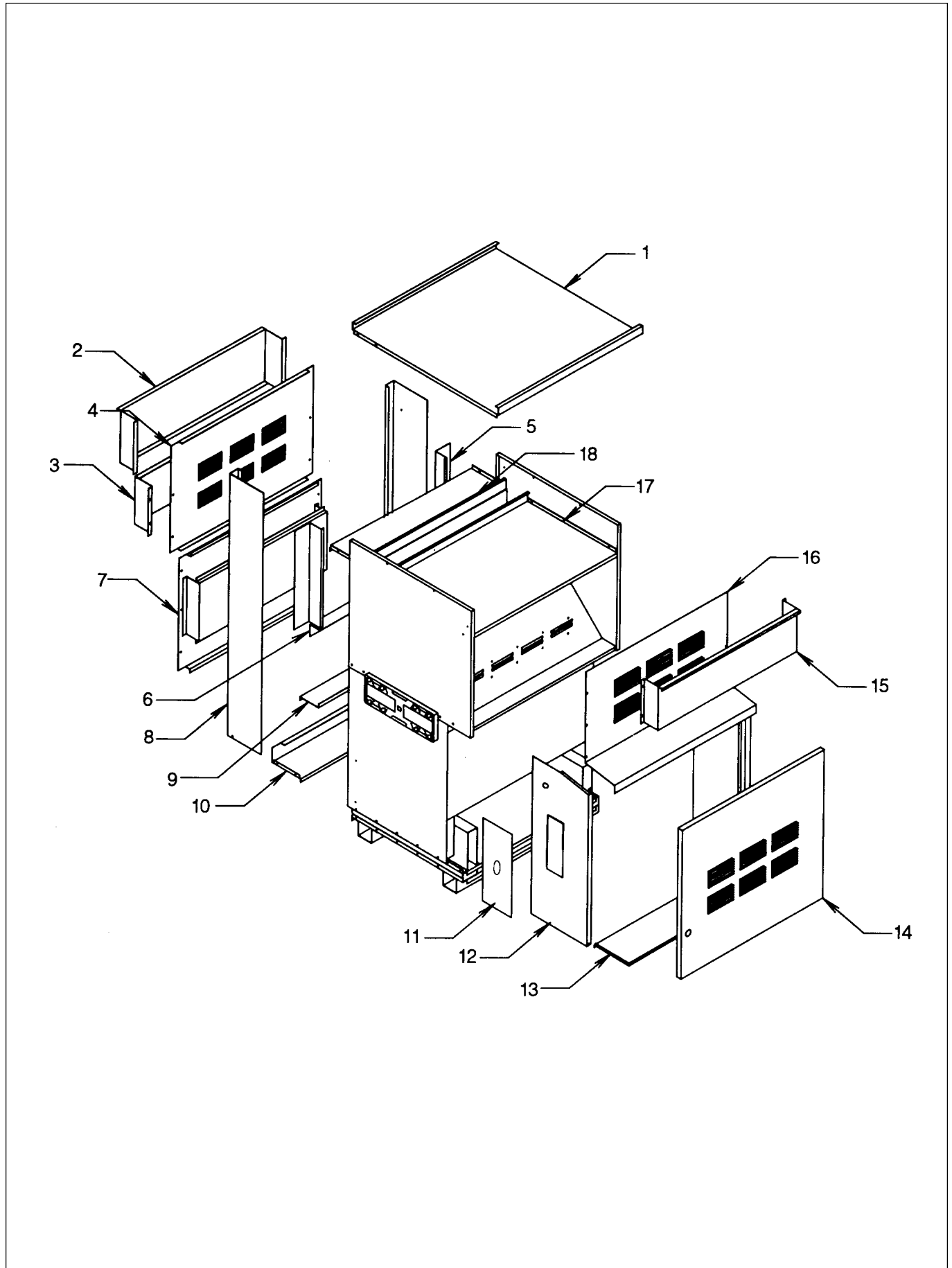


Figure 21. Outdoor Parts.

## SECTION 7. Outdoor Parts Descriptions and Order Numbers

Key Description No	Model 500	Model 600	Model 715	Model 850	Model 1010	Model 1200	Model 1430	Model 1670	Model 1825
1 Top Panel Assembly	10660701	10660702	10660703	10660704	10660705	10660706	10660707	10660708	10660709
2 Rear Windshield	10658101	10658102	10658103	10658104	10658105	10658106	10658107	10658108	10658109
3 Upper Rear Louver Shield	10657101	10657102	10657103	10657104	10657105	10657106	10657107	10657108	10657109
4 Rear Panel Upper	10658701	10658702	10658703	10658704	10658705	10658706	10658707	10658708	10658709
5 Gap Closure-Side	10660200 (2)	10660200 (2)	10660200 (2)	10660200 (2)	10660200 (2)	10660200 (2)	10660200 (2)	10660200 (2)	10660200 (2)
6 Gap Closure-Middle	10660100	10660100	10660100	10660100	10660100	10660100	10660100	10660100	10660100
7 Lower Rear Panel Assembly	10660501	10660502	10660503	10660504	10660505	10660506	10660507	10660508	10660509
8 Rear End Panel Lft. & Rt.	10657700 (2)	10657700 (2)	10657700(2) (2)	10657700 (2)	10657700 (2)	10657700 (2)	10657700 (2)	10657700 (2)	10657700 (2)
9 Lower Rear Shield Inner	10659901	10659902	10659903	10659904	10659905	10659906	10659907	10659908	10659909
10 Rear Base Extension	10658501	10658502	10658503	10658504	10658505	10658506	10658507	10658508	10658509
11 Gas Train Interface Plate	20050200	20050200	20050200	20050200	20050200	20050200	20050200	20050200	20050200
12 Front End Panel	10657500 (2)	10657500 (2)	10657500 (2)	10657500 (2)	10657500 (2)	10657500 (2)	10657500 (2)	10657500 (2)	10657500 (2)
13 Front Base Extension	10659701	10659702	10659703	10659704	10659705	10659706	10659707	10659708	10659709
14 Door	10660801	10660802	10660803	10660804	10660805 (2)	10660806 (2)	10660807 (2)	10660808 (2)	10660809 (2)
15 Front Windshield	10659101	10659102	10659103	10659104	10659105	10659106	10659107	10659108	10659109
16 Front Panel Upper	10658901	10658902	10658903	10658904	10658905	10658906	10658907	10658908	10658909
17 Flue Panel Front	10659501	10659502	10659503	10659504	10659505	10659506	10659507	10659508	10659509
18 Flue Panel Rear	10659301	10659302	10659303	10659304	10659305	10659306	10659307	10659308	10659309
19 Rain Shield-Control Box (Not shown)	10660400	10660400	10660400	10660400	10660400	10660400	10660400	10660400	10660400
<b>See Parts Illustration On Page 21</b>									
5 Rear Panel, Flue Collector	10661701	10661702	10661703	10661704	10661705	10661706	10661707	10661708	10661709
6 Rear Panel, Flue Collector Ext.	10661801	10661802	10661803	10661804	10661805	10661806	10661807	10661808	10661809

NOTE: Numbers in ( ) represent quantity required for each size. Quantity is one otherwise.

Key No	Description	Model 500	Model 600	Model 715	Model 850	Model 1010	Model 1200	Model 1430	Model 1670	Model 1825
7	Front Support, Flue Collector	10662101	10662102	10662103	10662104	10662105	10662106	10662107	10662108	10662109
8	Tile Cover, Front & Rear	10661501 (2)	10661502 (2)	10661503 (2)	10661504 (4)	10661505 (4)	10661506 (4)	10661507 (4)	10661508 (4)	10661509 (4)
10	Baffle, Heat Exchanger	10667701 (7)	10667702 (14)	10667703 (14)	10667704 (14)	10667705 (14)	10667706 (28)	10667707 (28)	10667708 (28)	10667709 (14)
41	Middle Front Panel	10662001	10662002	10662003	10662004	10662005	10662006	10662007	10662008	10662009
42	Sweep Sheet Flue Collector	10662201	10662202	10662203	10662204	10662205	10662206	10662207	10662208	10662209
48	Base Tile Support	10602301	10602302	10602303	10602304	10602305	10602306	10602307	10602308	10602309
69	Tube Assembly, Copper	10665901	10665902	10665903	10665904	10665905	10665906	10665907	10665908	10665909
70	Tube Assembly, Cupro-Nickel	10670401	10670402	10670403	10670404	10670405	10670406	10670407	10670408	10670409

NOTE: Numbers in ( ) represent quantity required for each size. Quantity is one otherwise.

# SECTION 8. Optional Parts Descriptions and Order Numbers

## Pump Rotating Sections and Repair Parts

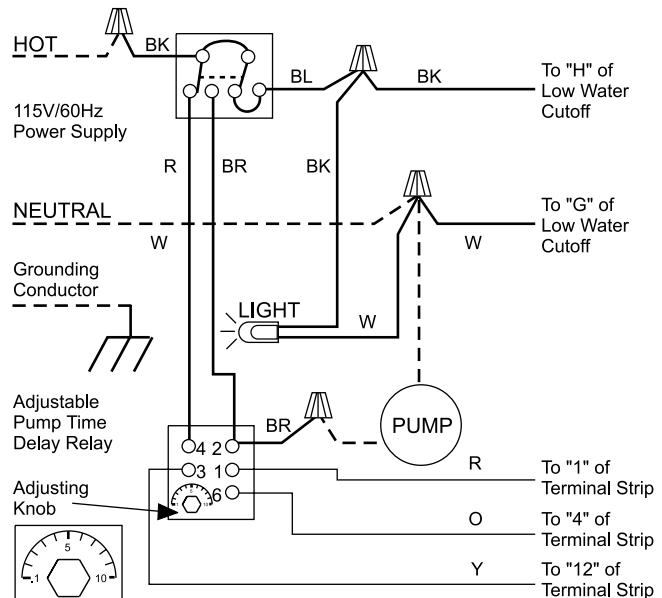
Check pump assembly on heater for H.P. rating and find correct Laars part number from table below.

Description	1/4 HP	1/3 HP	3/4 HP
Pump Rotating Assembly, B&G, 1522 w/3 " IMP, Bronze, 1P	A0048700	—	—
Pump Rotating Assembly, B&G, Series 90 w/3 " Impeller, 1P	A0077100	—	—
Pump Rotating Assembly, TACO 1630 w/3 " Impeller, 1P	A0071000	—	—
Pump Rotating Assembly, TACO 1630 w/4" Impeller, 1P	—	A0071200	—
Pump Rotating Assembly, B&G, 1522 w/4" Impeller, Bronze, 1P	—	A0047500	—
Pump Rotating Assembly, B&G Series 90, w/4" Impeller, 1P	—	A0077200	—
Pump Rotating Assembly, TACO 1630 w/5 " Impeller, 1P	—	—	A0071400
Pump Rotating Assembly, B&G 1522 w/5 " Impeller, Bronze, 1P	—	—	A0047700
Pump Rotating Assembly, B&G Series 90, w/5 ", Impeller, 1P	—	—	A0077300
Motor, Pump, B&G 1522 - 1 P	A0054400	A0054800	A0055600
Coupler, Pump, B&G - Universal	A0020200	A0020200	A0020200
Bearing Assembly, Pump, B&G 1522 - Universal	A0021600	A0021600	A0021600
Bearing Assembly, Pump, B&G 1522, Bronze	A0022100	A0022100	A0022100
Gasket, Pump, B&G 1522 - #PW1 -2151	A0021400	A0021400	A0021400
Mounting Ring, B&G 1522 Motors	A0065100	A0065100	A0065100
Impeller, B&G 1522 - 3"	A0058100	A0058100	A0058100
Impeller, B&G 1522 - 4"	A0058200	A0058200	A0058200
Impeller, B&G 1522 - 5"	A0058400	A0058400	A0058400
Automatic Reset Temp. Limit Switch .....			E0014400
Manual Reset High Gas Pressure Switch .....			E0023300
Manual Reset Low Gas Pressure Switch .....			E0023500
Alarm Bell, 110 Volts .....			A0014200
Outdoor Reset, Single Stage 30' Bulb .....			E0067600
Outdoor Reset, Two Stage, 30' Bulb .....			E0084200
Low-water Cut-off, Electronic, Manual Reset .....			E0067900
Low-water Cut-off, Electronic, Automatic Reset With Test Button .....			E2024200

Gas valve types and sizes vary with different boiler models, with different fuels and with different firing options. For service and replacement, copy exact number from nameplate giving manufacturer's name and pipe size.

### Energy Management Monitor (EM<sup>2</sup>)

STANDARD COMPONENTS	
Description	Part No.
On/Off Auto Switch	E0109200
Time Delay Relay, 24 VAC	E2077700
Time Delay Relay, 120 VAC	E2077800
OPTIONAL EQUIPMENT	
Description	Part No.
Remote Aquastat, 110-240F	E0014400
Immersion Well	E0025900
Note: The Remote Aquastat and the Immersion Well, when required, should be ordered separately.	



#### WIRING CODE

Factory Wiring      Field Wiring  
 24 Volt      110 Volt  
 110 Volt

BK — Black      R — Red  
 BL — Blue      Y — Yellow  
 BR — Brown      W — White  
 O — Orange



H0105000D