

# Magnetic Boiler Filter

Powered by Adey

The industry leading filtration device is designed to protect hydronic heating systems by capturing magnetite and iron oxides



## How it works in just minutes



Iron oxide sludge and debris collects in the system.



The NaviClean™ filter is placed into the system...



Within seconds, the water begins to clear as NaviClean starts to work...



In minutes, the NaviClean filter traps the debris, and water is clear...

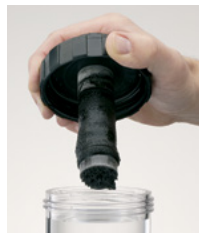

The NaviClean filter is removed for easy, rinse-down cleaning.

# NaviClean™ Magnetic Boiler Filter

Advanced filtration for hydronic heating systems

The NaviClean™ is designed to work with Navien NCB-E, NHB and NFB Series boilers. It is best suited for heating systems with 1" to 1-1/4" copper or black iron pipes. It features a permanent magnet mounted inside the glass reinforced nylon housing.

- Powerful permanent magnet for removing higher levels of iron oxide, sludge and debris
- Inlet and outlet ports for rapid in-line installation
- Tool-free valve connection designed to prevent cross threading
- Large canister and full flow valves resulting in minimal pressure drop and unrestricted flow
- Low profile drain valve making installation and service easier
- 360° rotation allowing flexibility of installation
- High performance seals providing higher protection against leaks

## Homeowner benefits

- Long-term system protection extends life of the heating system and results in improved system efficiency
- Simple design and easy to service minimizes maintenance costs
- Lifetime magnet lifecycle reduces operating costs
- Minimal effect on boiler pressure
- Up to 95% capture rate on first pass

## Recommended installations

The NaviClean Magnetic Boiler Filter can be installed anywhere on the main system piping. To achieve best performance, it is recommended that the NaviClean be installed after the last heating zone and before the boiler. NaviClean is also fully compatible with Adey chemicals.



## What's in the box

- NaviClean filter
- Lid wrench
- 2 1-1/4" NPT adapters
- Valve wrench
- 2 isolation valves
- Installation, operation and service manual
- 2 valve clips

## Customizable installation

Unusual pipe angles? Limited space? No problem. The in-line design and 360° rotational valves of NaviClean allow installers to customize the job to fit almost any space — no matter how unusual — for maximum flexibility and minimum hassle.

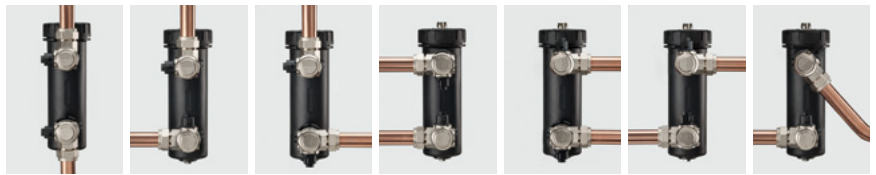

Product	Part Number	UPC
NaviClean Magnetic Filter for Boilers	GXXX001727	884954089805

Shipping weight 7.5 lbs. Shipping box size 12"L x 7"D x 5"H

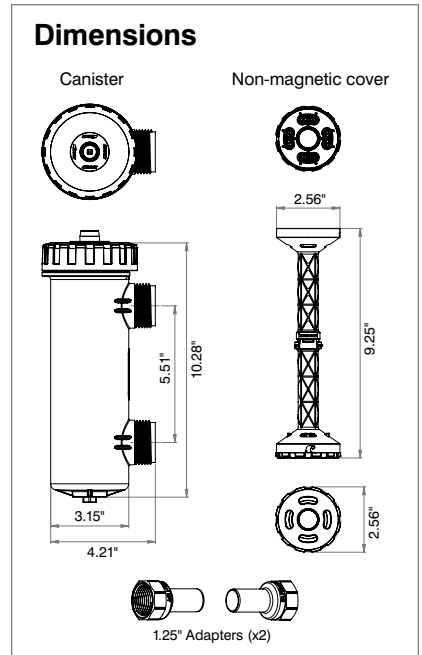

## Operating conditions

- Maximum working pressure 87 psi
- Flows up to 21 GPM
- Temperature range between 37°F and 203°F (3°C and 95°C)