

**This Boiler must be installed by a licensed and trained Heating Technician; otherwise the warranty of this unit is void. Failure to properly install this unit could cause damage to property and injury to occupants possibly resulting in death.**

# Trinity Ti

Trinity Ti Boiler Only  
VERSION DATE: 2-9-09

## Installation and Operation Instructions

- 1.0 SPECIFICATIONS .....2
- 1.1 HIGH ALTITUDE OPERATION .....2
- 2.0 INSTALLATION REQUIREMENTS .....2
- 3.0 VENTING .....4
- 3.1 VENT PIPE MATERIAL .....4
- 3.3 VENTING RULES AND GUIDELINES .....7
- 3.4 VENTING CLEARANCES .....7
- 4.0 CONDENSATE DRAIN .....9
- 5.0 INSTALLING GAS PIPING .....9
- 5.0 INSTALLING GAS PIPING .....10
- 5.1 INSTALLATION .....10
- 5.2 TESTING AND SETTINGS .....10
- 6.0 HEATING SYSTEM PIPING .....12
- 6.1 PRIMARY LOOP PLUMBING .....13
- 6.2 SECONDARY LOOP HEATING SYSTEM .....16
- 6.2.1 Multiple Zones using Zone Valves .....16
- 6.2.2 Multiple Zones using Pumps .....16
- 6.2.3 Multiple Zones with Different Temperatures .....17
- 6.3 DOMESTIC COMBI SYSTEM .....18
- 7.0 WIRING .....20
- 7.1 SIMPLIFIED WIRING CONNECTIONS .....21
- 7.2 ADVANCED WIRING SYSTEMS .....22
- 7.2.1 Multiple 4 wire Zone Valves .....22
- 7.2.2 Multiple Zones with Taco Valve controller .....23
- 7.2.3 Multiple Zones Pump controller .....24
- 7.2.4 Multiple Temperature Zones with Injection Pumps .....25
- 8.0 SENTRY 2100 CONTROLLER .....26
- 9.0 LIGHTING BOILER .....30
- 9.1 INITIAL START-UP .....30
- 9.2 RE-LIGHTING UNIT .....30
- 9.3 TURN OFF BOILER .....30
- 10.0 TROUBLE SHOOTING .....31
- 11.0 SEQUENCE OF OPERATION .....34
- 14.0 ANNUAL MAINTENANCE AND INSPECTION .....36
- 14.1 COMBUSTION CHAMBER CLEANING .....36
- 15.0 PARTS LIST .....37



**CAUTION:**

**IT IS THE RESPONSIBILITY OF THE HOMEOWNER TO KEEP THE VENT TERMINAL CLEAR OF SNOW AND ICE.**

## 1.0 SPECIFICATIONS

Description	Ti 100	Ti 150	Ti 200	Ti 400
Input (BTUx1000)	Natural =100 / 15	Natural =150 / 25	Natural = 200 / 25	Natural = 399 / 75
Input Capacity - Max. / Min.	Propane= 100 / 15	Propane= 145 / 25	Propane= 194 / 25	Propane= 399 / 75
Output (BTUx1000)	Natural =92.7 / 13.9	Natural =139 / 23.2	Natural = 185 / 23.2	Natural = 370 / 69.5
Output Capacity - Max./ Min.	Propane = 92.7/ 13.9	Propane = 134 / 23.2	Propane = 180 / 23.2	Propane = 370 / 69.5
Steady State Efficiency	95%	95%	94%	94%
AFUE Efficiency	92.7%			
Venting material	CPVC, PVC (See Section 3.1) <b>(Note: PVC not permitted in Canada)</b>			
Max. Vent lengths Natural Gas	3" @ 105' Equivalent	3" @ 105' Equivalent		4" @ 30' Equivalent
Max. Vent lengths Propane		3" @ 50' Equivalent		6" @ 65' Equivalent
Weight	80 lbs.	80 lbs.	110 lbs.	205 lbs.
Dimensions L-W-D (Inches)	22.5x15.25x14	22.5x15.25x14	22.5x15.25x17.25	23.5x21 x36
Clearance to Combustibles	0"			

### 1.1 High Altitude Operation

The Trinity boiler is designed to operate to capacity in installations with 2000 feet of elevation or less. As elevations higher than 2000 feet have less dense air, the unit is not capable of providing its specified capacity. (See Chart).

#### In Canada:

De-rate by 5% for altitudes between 2000 and 4500 feet. For altitudes above 4500 feet consult with local authorities.

#### In USA:

De-rate by 4% for every 1000 feet over 2000 feet.

**CAUTION** At elevations greater than 2000 feet, the combustion of the Trinity must be checked with a calibrated combustion tester to ensure safe and reliable operation.

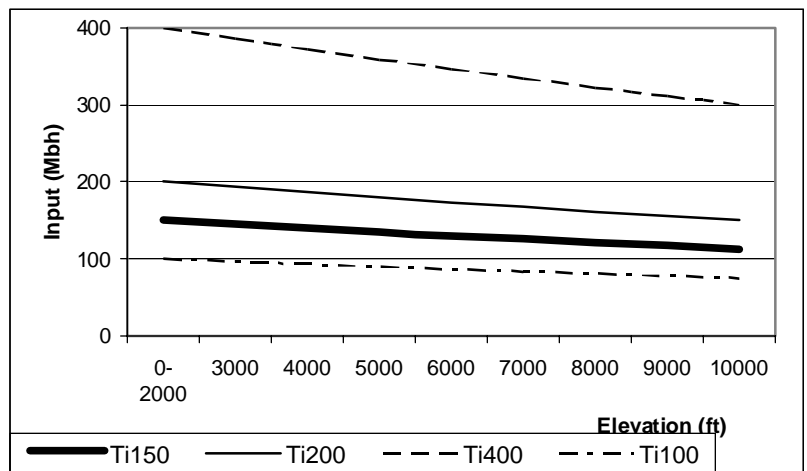

Consult Section 5.20 for instructions on adjusting the input to provide proper operation. **It is the *Installers responsibility* to check the combustion, and to adjust the combustion in accordance to Section 5.2**

## 2.0 INSTALLATION REQUIREMENTS

### Important: Carbon Monoxide Detectors

The installation of your NY Thermal Trinity gas boiler must conform to the requirements of your local authority, and the National Fuel Gas Code ANSI Z223.1 and or CAN/CGA B149 Installation Codes. Where required by the Authority, the installation must conform to the standard for "Controls and Safety Devices for Automatically Fired Boilers ANSI/ASME CSD-1.



### **Warning**

**THIS BOILER MUST HAVE WATER FLOWING THROUGH IT WHENEVER THE BURNER IS ON. FAILURE TO DO THIS WILL DAMAGE THE UNIT AND VOID THE WARRANTY.**

### **ATTENTION: LIQUEFIED PETROLEUM (LP) PROPANE**

The Trinity boiler is set to operate with Natural Gas; LP Conversion Kit Part No. 82650-1 for Ti100's, Ti150's and Ti200's, or LP Conversion Kit Part No. 83017-1 for Ti400's is included with each boiler and must be installed before operating with Propane.

Liquefied Petroleum (LP) propane gas is heavier than air; it is imperative that your boiler is not installed in a pit or similar location that will permit heavier than air gas to collect. Local Codes may require appliances fueled with LP gas be provided with an approved means, of removing unburned gases from the room. Check your local codes for this requirement.

**“In the State of Massachusetts only”**

(a) For all horizontally vented gas fueled equipment installed in every dwelling, building or structure used in whole or in part for residential purposes, including those owned and operated by the Commonwealth and where the side wall exhaust vent termination is less than seven (7) feet above finished grade in the area of the venting, including but not limited to decks and porches, the following requirements shall be satisfied:

1. **INSTALLATION OF CARBON MONOXIDE DETECTORS.** At the time of installation of the side wall horizontal vented gas fueled equipment, the installing plumber or gas fitter shall observe that a hard wired carbon monoxide detector with an alarm and battery back-up is installed on the floor level where the gas equipment is to be installed and on each additional level of the dwelling, building or structure served by the equipment. It shall be the responsibility of the property owner to secure the services of qualified licensed professionals for the installation of hard wired carbon monoxide detectors.
  - a. In the event that the side wall horizontally vented gas fueled equipment is installed in a crawl space or an attic, the hard wired carbon monoxide detector with alarm and battery back-up may be installed on the next adjacent floor level.
  - b. In the event that the requirements of this subdivision can not be met at the time of completion of installation, the owner shall have a period of 30 days to comply with the above requirements; provided, however, that during said 30 day period a battery operated carbon monoxide detector with an alarm shall be installed.
2. **APPROVED CARBON MONOXIDE DETECTORS.** Each carbon monoxide detector as required in accordance with the above provisions shall comply with NFPA 720 and be ANSI/UL 2034 listed and IAS certified.
3. **SIGNAGE.** A metal or plastic identification plate shall be permanently mounted to the exterior of the building at a minimum height of eight (8) feet above grade directly in line with the exhaust vent terminal for the horizontally vented gas fueled heating appliance or equipment. The sign shall read, in print size no less than one-half (1/2) inch in size, **“GAS VENT DIRECTLY BELOW. KEEP CLEAR OF ALL OBSTRUCTIONS”**. *(Plate include with boiler)*
4. **INSPECTION.** The state or local gas inspector of the side wall horizontally vented gas fueled equipment shall not approve the installation unless, upon inspection, the inspector observes carbon monoxide detectors and signage installed in accordance with the provisions of 248 CMR 5.08(2)(a)1 through 4.

(b) **EXEMPTIONS:** The following equipment is exempt from 248 CMR 5.08(2)(a)1 through 4:

1. The equipment listed in Chapter 10 entitled “Equipment Not Required To Be Vented” in the most current edition of NFPA 54 as adopted by the Board; and
2. Product Approved side wall horizontally vented gas fueled equipment installed in a room or structure separate from the dwelling, building or structure used in whole or in part for residential purposes.

(c) **MANUFACTURER REQUIREMENTS – GAS EQUIPMENT VENTING SYSTEM PROVIDED.** When the manufacturer of Product Approved side wall horizontally vented gas equipment provides a venting system design or venting system components with the equipment, the instructions provided by the manufacturer for installation of the equipment and the venting system shall include:

1. Detailed instructions for the installation of the venting system design or the venting system components; and
2. A complete parts list for the venting system design or venting system.

(d) **MANUFACTURER REQUIREMENTS – GAS EQUIPMENT VENTING SYSTEM NOT PROVIDED.** When the manufacturer of a Product Approved side wall horizontally vented gas fueled equipment does not provide the parts for venting the flue gases, but identifies “special venting systems”, the following requirements shall be satisfied by the manufacturer:

1. The referenced “special venting system” instructions shall be included with the appliance or equipment installation instructions; and
2. The “special venting systems” shall be Product Approved by the Board, and the instructions for that system shall include a parts list and detailed installation instructions.

(e) A copy of all installation instructions for all Product Approved side wall horizontally vented gas fueled equipment, all venting instructions, all parts lists for venting instructions, and/or all venting design instructions shall remain with the appliance or equipment at the completion of the installation.

## 2.1 Location

In all cases, the Trinity boiler must be installed indoors, in a dry location, such that the gas components are protected from dripping or spraying water or rain, during operation and servicing. The boiler location ambient temperature is maintained to a minimum of 50°F. Determine the best location of the vent termination, and if possible locate the boiler as close to the termination point as possible.

### Clearances

**For proper and safe installation adhere to the following clearances to combustibles:**

Boiler Casing=0" Floor=Combustible Flue Pipe: Boxed in or enclosed=2" In free air=0"

**The following are the minimum clearances for servicing, however 24" is recommended:**

Front = 24" Back = 0" Top = 12" Sides = 12" Bottom = 9" (0" for Ti400)

## 3.0 VENTING

The NY Thermal Trinity condensing gas boiler is a high efficiency boiler utilizing induced power venting. Exhaust gases are to be vented directly outdoors, using the venting methods detailed in this section. Under no conditions may this unit vent gases into a masonry chimney, unless it is vacant, and utilizes the Trinity approved venting material as illustrated in this section. Installation must comply with local requirements and with the National Fuel Gas Code, ANSI Z223.1 for U.S. installations or CSA B149.1 for Canadian Installations.

It is recommended that two elbows be used, so that the slope of the horizontal exhaust vent does not affect the vertical plumb of the pipe connected to the boiler. Slope all horizontal indoor exhaust venting 1/4" to 1/2" per linear foot.

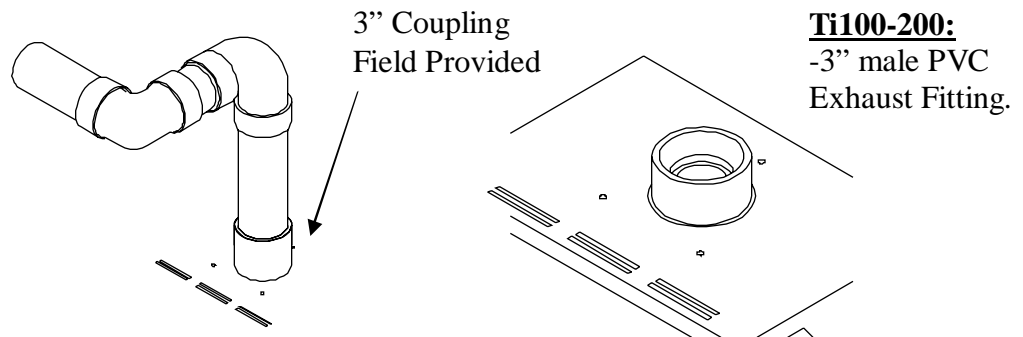

### Attaching Vent Piping to Boiler

- It is extremely important for the intake and exhaust piping to be adapted to the appropriate size immediately upon exiting the boiler cabinet. Ti100-200's come with a 3"x1-1/2" PVC adapter to be used to immediately connect to the air intake port of the boiler.
- **Ti100-200** exhaust connection is 3" male PVC, use approved cement to connect to venting system.
- **Ti400** exhaust connection accepts approved 4" venting material, **do not** insert PVC pipe directly into the exhaust connection; PVC pipe could become deformed by the clamping force of the gear clamp. Only approved CPVC can be inserted into the Ti400 exhaust connection. Note: a 4" long piece of 4" CPVC is provided with the Ti400.
- Check the flue outlet gasket for proper insertion and sealing prior to and after attaching the venting.
- Ensure the venting system does not apply a load or stain on the flue outlet of the boiler (recommend using two elbows to create a "swing joint" as shown above).

## 3.1 Vent Pipe Material

### Exhaust Vent Piping:

- The first **3 feet** of the exhaust venting must be readily accessible for inspection.
- In **Canada** all exhaust pipe, fittings and cement must comply with **ULC S636** (As per ULC S636 only CPVC can be used).
- In **U.S.** exhaust pipe and fittings must comply with **ANSI/ASTM D1784** and **DF441** for PVC and CPVC respectively. Cement and primer must comply with **ANSI/ASTM D2564** and **F493** for PVC and CPVC respectively.
- **Ti100-200**
  - 3" PVC Sch.40 (**US only, not permitted in Canada**).
  - 3" CPVC Sch.40.
- **Ti400**
  - 4 or 6" PVC Sch.40 (**US only, not permitted in Canada**).
  - 4 or 6" CPVC Sch.40.

### Air Supply Pipe:

- 3" ABS. (Use 4" or 6" for Ti400)
- 3" PVC Sch.40. (Use 4" or 6" for Ti400)

## 3.2 Venting Configurations

### 3.2.1 Two-Pipe Vent Termination

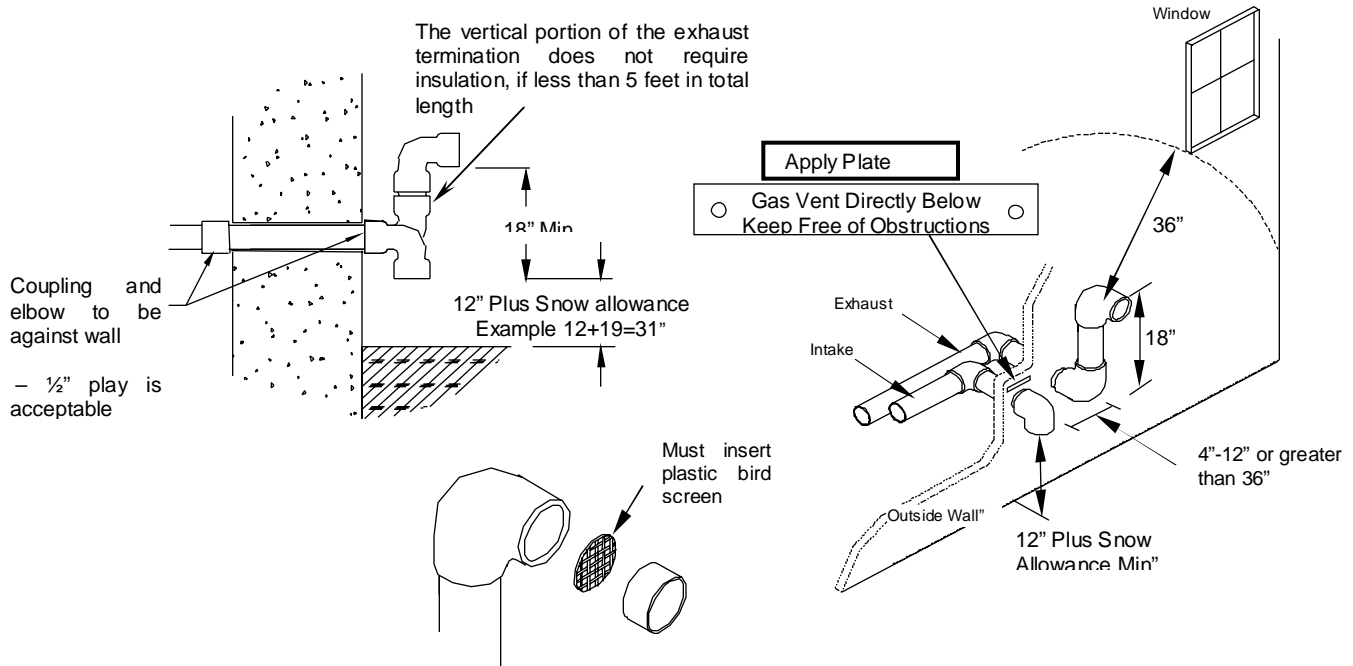

### 3.2.2 Concentric Vent Termination (No longer approved for Canada)

- Ti100-200 Only (Not for use with Ti400)
- NTI part number 82666 (York part number 1CT0303)
- Instructions included with vent terminal contain more detailed assembly and installation instructions.
- Clearances and requirements of this manual supersede those of the instructions included with the vent terminal.
- Terminal must be cemented together during installation.

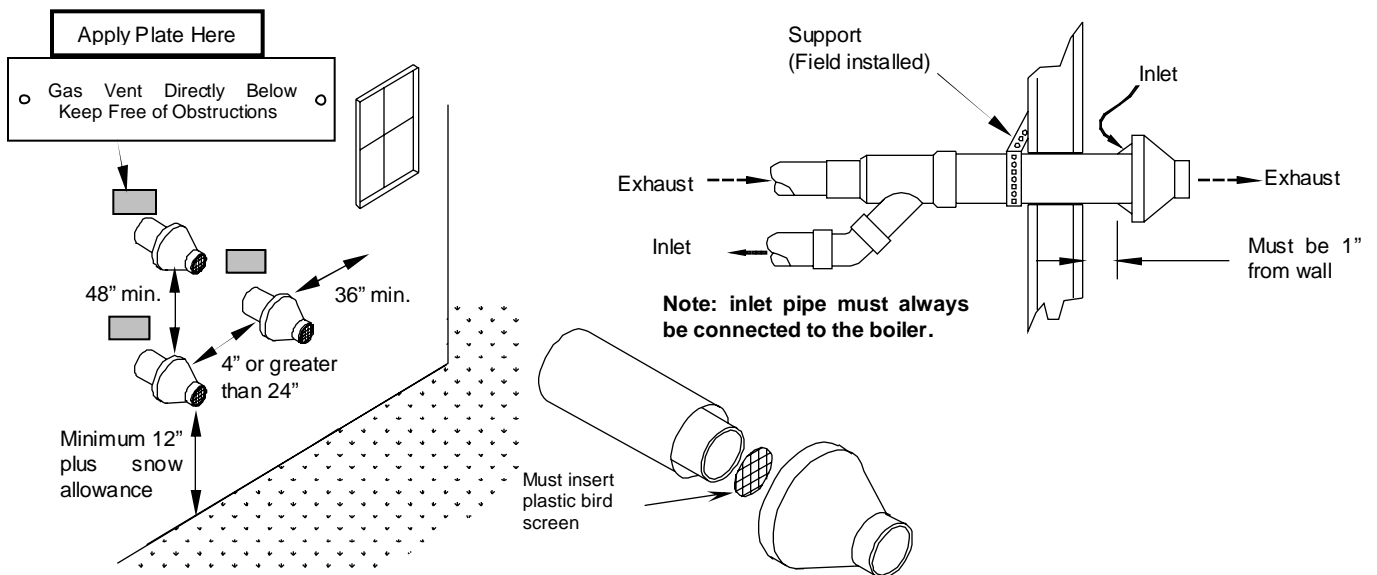

### 3.2.3 Ti400 Optional Vent Termination Kit

- NTI part number 83236.
- For use with Ti400 only.
- 4" Connections (When venting with 6", must adapt down at terminal)
- See Installation Manual included in vent terminal kit for further instructions.

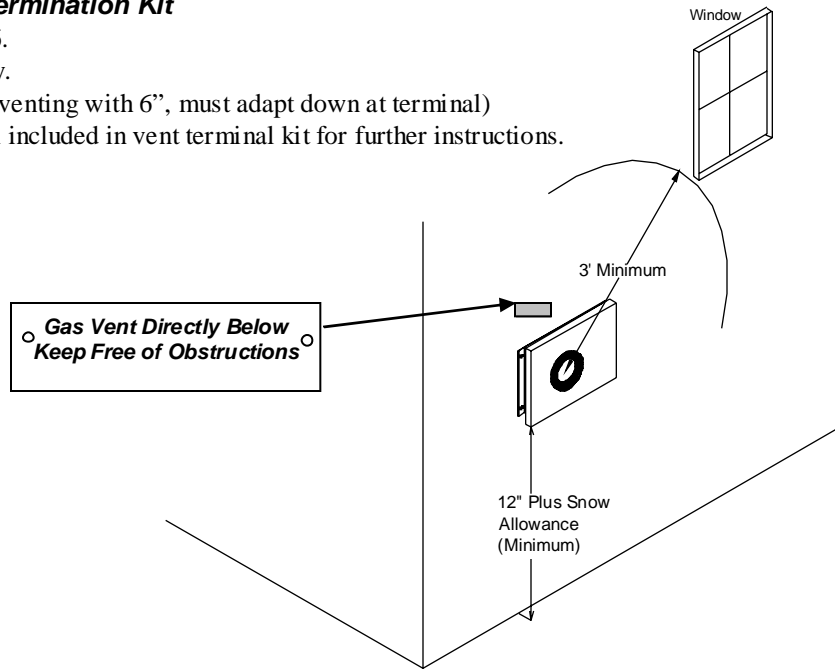

### 3.2.4 Roof Venting

It is permissible to run vent pipe through an existing chimney as long as:

- 1) The chimney is not being used by any other appliance.
- 2) Flue gases don't enter the vacant chimney.
- 3) Only Trinity certified venting materials are used, see Section 3.1.
- 4) Vent lengths are within the maximums specified.

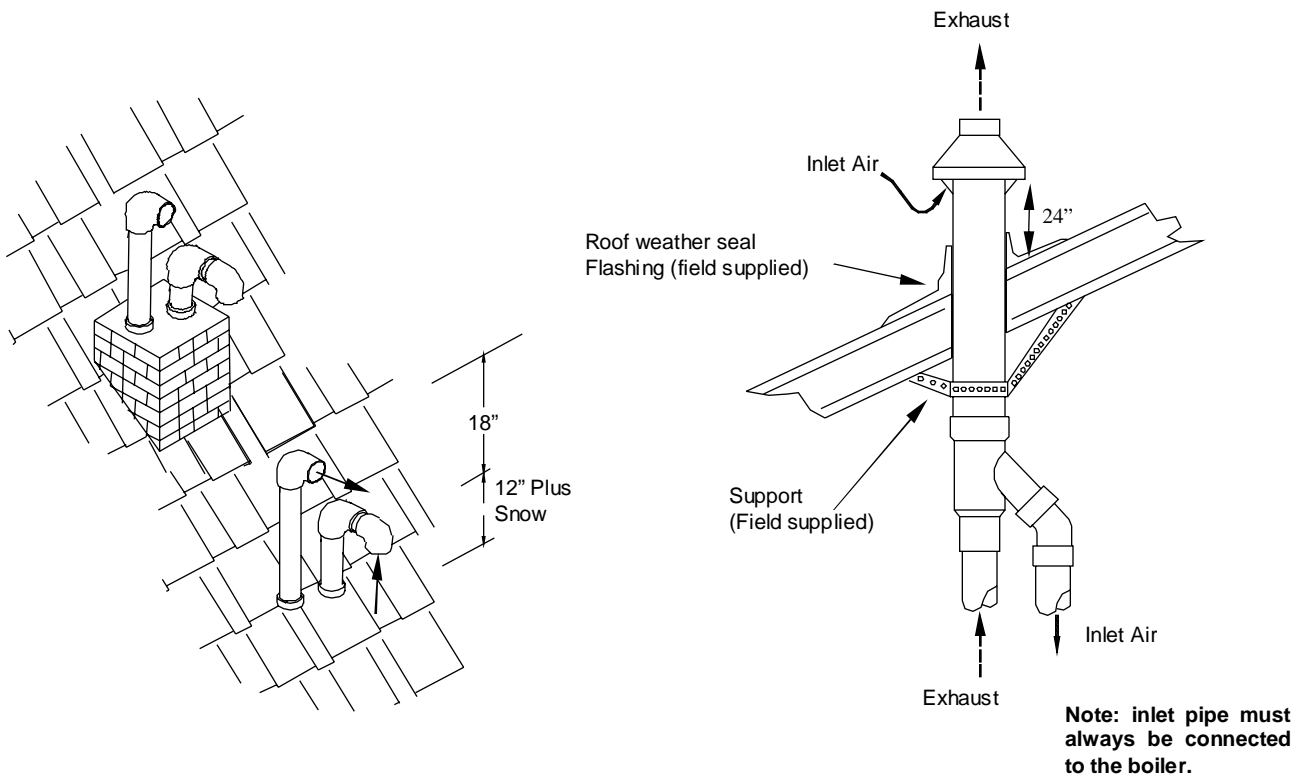

### 3.3 Venting Rules and Guidelines

1. It is highly recommended that the vent terminal be located where it will not be exposed to normal prevailing winds.
2. Air for combustion must be drawn from outdoors from an area free of dust and contaminants. Combustion air containing chemicals such as chloride, fluoride, bromine or iodine, will cause corrosion damage of the heat exchanger voiding your NTI warranty. Avoid drawing combustion air from the vicinity of swimming pools, laundry facilities, workshops, or other areas where the air may contain chemicals or dust.
3. The exhaust must be a minimum of 18" above the air inlet, and the air inlet must always be a minimum of 12" plus snow allowance above any surface that will support snow. (Two feet plus snow allowance is highly recommended). Consult your weather office, for the maximum typical snowfall for your region. Example: New Brunswick Canada the typical maximum snowfall is 19", Thus in figures of Section 3.3, the inlet must be  $(12''+19'') = 31''$  off the ground, the exhaust must be  $(31''+18'') = 49''$ .
4. The horizontal distance between the inlet and exhaust must be a minimum of 4" center to center. If the horizontal distance between the inlet and exhaust is more than 12", increase the vertical separation by the same amount. Example: If horizontal separation is 24", a minimum vertical separation of 30" is required  $(24''-12''=12'')$ , so increase minimum vertical separation by 12",  $(18''+12''=30'')$ . If horizontal distance is greater than 6', no additional vertical spacing is required. Vertical separation is never required to be greater than 36".
5. Under normal operating conditions this appliance will produce a plume of white gases, and should be taken into consideration when selecting an adequate location. A 3' diameter stainless, plastic, or vinyl shield can be used to flash the exterior of the residence.
6. If the horizontal distance between the inlet and exhaust is more than 12", increase minimum vertical separation by the same amount. (If horizontal distance is greater than 6', no additional vertical spacing is required). Example, horizontal separation equal to 24" requires a minimum vertical separation of  $18''+(24''-12'')=30''$ . (Vertical separation is never required to be greater than 36")
7. Elbows on outside of wall must be no greater than 1/2" away from the wall.
8. All indoor exhaust piping must be on a slope back to the boiler a minimum of 1/4" per linear foot of vent. For applications where excessive condensation is possible 1/2" per linear foot is recommended.
9. Exhaust vent pipe can be secured to the wall for more rigidity.
10. In all roof applications the discharge must point away from the pitch of the roof.
11. Install adequate flashing where the pipe enters the roof, to prevent water leakage.
12. Install and seal a rain cap over existing chimney openings, in vacant chimney applications.
13. For installations that exit the wall below grade. Excavate site as shown in figure, to a point below where the pipes are to exit. Ensure that the wall is fully sealed where the pipes penetrate the wall. The vent piping MUST be secured to the side of the building above grade, as shown, to provide rigidity. NTI Provides a mounting bracket PN. 82075 for securing the exhaust pipes. Ensure that the vent clearances are maintained (Inlet minimum 12" plus snow allowance from grade, exhaust outlet 18" minimum above inlet)
14. Install the vent screens provided into both the inlet and exhaust vent terminal elbows. The screen must be on the outside of the last elbow. Install the screen into the female opening of the elbow. Then cut a small piece of pipe to sandwich the screen into the elbow. NOTE be sure that the small piece of pipe cut, does not extend past the end of the elbow. Two screens are provided in the package.
15. It is extremely important that the intake and exhaust piping be adapted to the appropriate size immediately upon exiting the boiler cabinet.
16. All interior vent pipe shall be supported a minimum of every 36" (6"-diameter pipe used with the Ti400, need only be supported every 48").
17. Install the warning plate "Gas Vent Directly Below" 4 feet above the location of the air inlet pipe, so it is visible from at least eight (8) feet away.

*Installing Venting Below Grade*

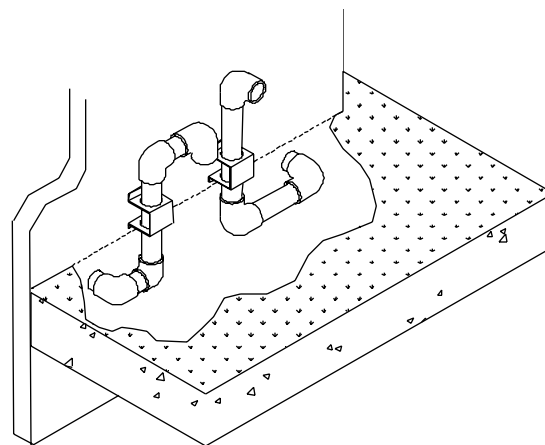

### 3.4 Venting Clearances

**These are code restrictions for the location of the Flue gas vent terminal. Compliance doesn't insure a satisfactory installation; good common sense must also be applied.**

#### **The vent terminal shall not terminate:**

1. Directly above a paved sidewalk or a paved driveway that is located between two buildings, and that serves both buildings;
2. Less than 7 feet above grade where located adjacent to a paved walkway or driveway located on public property.
3. Within 3' (three feet) of a window or door that can be opened, or non-mechanical air supply inlet to any building.

4. Within 6' of a mechanical air supply inlet to any building, or roof eve containing soffit openings.
5. Above a meter/regulator assembly within 3' horizontally of the vertical centerline of the regulator.
6. Within 3' horizontally of any gas service regulator vent outlet up to a height of 15'.
7. Less than 30" plus snow allowance above grade, or any surface that will support snow, ice, or debris. The exhaust must be a minimum of 18" above the air inlet, and the air inlet must always be a minimum of 12" plus snow allowance above any surface that will support snow. (Two feet plus snow allowance is highly recommended). Consult your weather office, for the maximum typical snowfall for your region.
8. Underneath a wooden verandah, porch, or deck.
9. Underneath cement verandah, porch, or deck, unless both ends are open and the exhaust pipe is installed at least 24" under the deck floor.
10. So situated that the flue gases are directed towards brickwork, siding, or other construction, in such a manner that may cause damage from heat or condensate from the flue gases.
11. Less than 3' from an inside corner of an L-shaped structure (including walls and fences).

### 3.5 Determining Vent Lengths

Use the following chart to determine the maximum amount of vent pipe that can be used. This chart calculates, sweep and 45° elbows, and 90° elbows at 5 equivalent feet. Note: chart shows allowable equivalent vent lengths for intake and exhaust vents separately, thus a Ti100 can be installed with 105 equivalent feet of intake venting and 105 equivalent feet of exhaust venting.

**IMPORTANT:**

- The length of one vent pipe (intake or exhaust) may not exceed the length of the other vent pipe by more than 20 equivalent feet.
- The three 90° elbows of the exterior vent piping (two outlet, and one inlet) do not have to be included, as they are taken into consideration in the vent calculations.
- For 150 and 200 Models, Propane Gas (LP) maximum vent length cannot exceed 50 equivalent feet.

Model	size	Type	Length	1	2	3	4	5	6	7	8	9
Ti100	3"	NG,LP	105	100	95	90	85	80	75	70	65	60
Ti150-200	3"	Natural	105	100	95	90	85	80	75	70	65	60
Ti150-200	3"	LP	50	45	40	35	30	25	20	15	10	5
Ti400	4"	Natural	30	25	20	15	10	5				
	6"	& LP	65	60	55	50	45	40	35	30	25	20

### 3.6 Outdoor Horizontal Venting

Vent piping outside the Building is permitted under the following conditions:

1. The maximum length outside the building is 20 feet. (Outdoor length must be included in the overall vent length calculation.)
2. Only 3" pipe can be used for Ti100-200, only 4" pipe can be used for Ti400.
3. All normal termination clearances are maintained.
4. All exterior exhaust vent pipes are insulated with 3.5"-ID, ½"-thick, for Ti100-200, or 4.5"-ID, ½"-thick, for Ti400, **Closed Cell Foamed Polyolefin Tubing** i.e., "Tundra Seal Plus" or equivalent.
5. The pipe is supported every 24"
6. The exhaust and inlet are sloped back to the boiler ½" elevation for every foot.

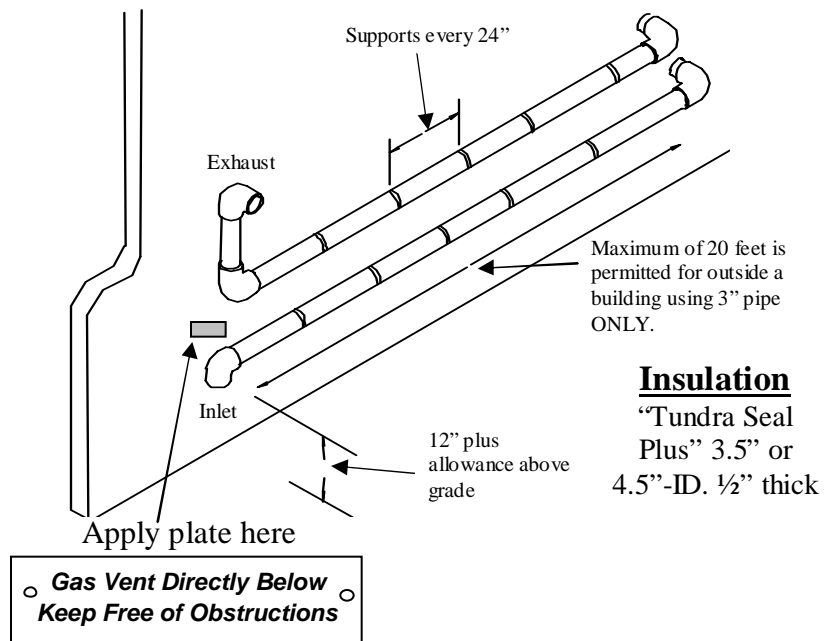

#### 4.0 CONDENSATE DRAIN

This unit produces water as a product of combustion. Much of this water condenses on the heat exchanger and in the venting system. All exhaust piping must be on a slope back to the boiler 1/4" per linear foot of vent. Steps must be taken to ensure that condensate does not collect in the venting system. Condensate must be drained from the boiler into a household drain.



#### Warning

**Failure to properly connect the condensate line will cause combustion gases to enter the room, possibly causing serious injury to occupants or death.**

**Note: check with your municipality, or local gas company to determine if disposal of combustion condensate is permitted. In the State of Massachusetts the condensate must be neutralized prior to entering a drain.**

The following are important notes that must be taken into consideration when constructing the condensate system:

- **DO NOT** run condensate line outside. A frozen or blocked drain will cause the condensate to fill the combustion chamber. This will result in a no heat condition, as the unit will shut down, and damage to the flame sensor, and components can occur.
- **NEVER** use copper, steel, or galvanized piping in the construction of the condensate system (condensate is very corrosive and will wrought most metals).
- When a condensate pump is used or required, select a pump that is designed for residential furnaces.

#### Warning:

The condensate drain kit supplied with each boiler is susceptible to flooding if the drain hose exiting the kit is lengthened or inserted into a drain. If additional length is required, do not use the drain kit provided, instead fabricate a 15" trap using tubing suitable for condensate disposal.

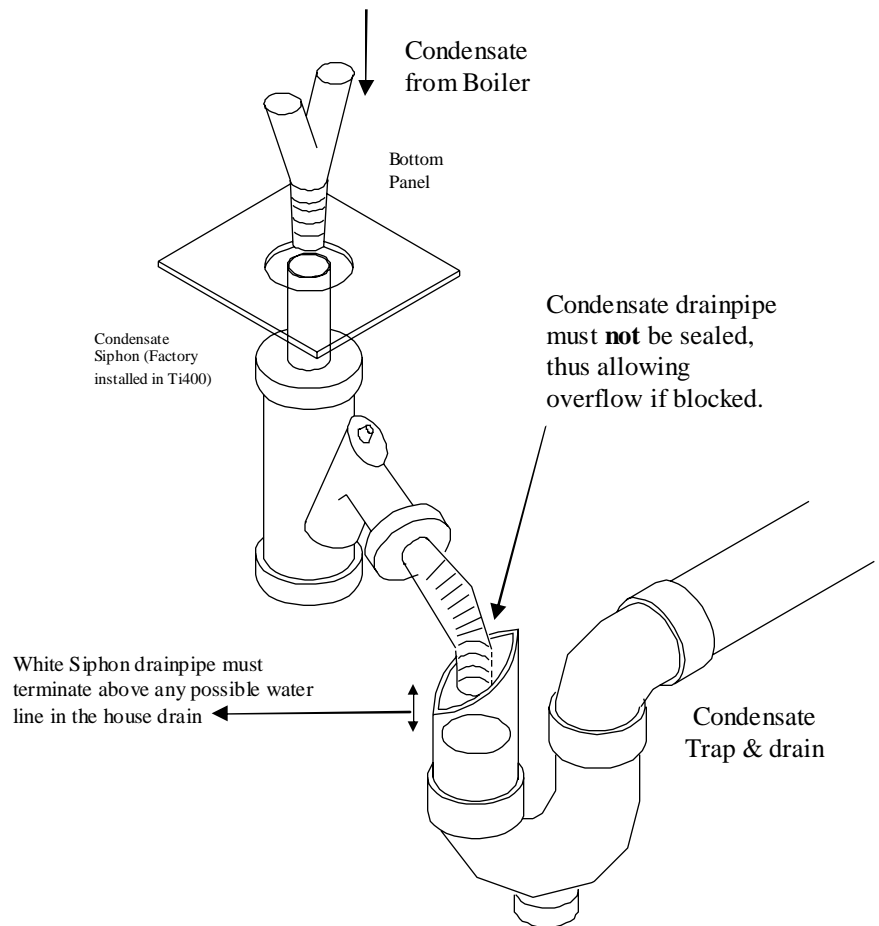
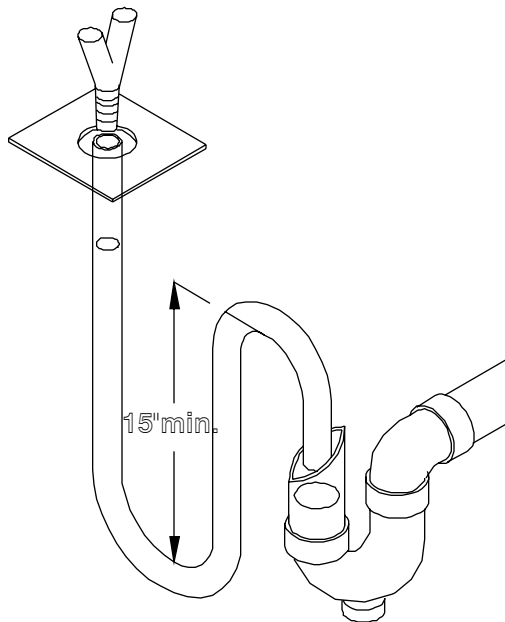

## 5.0 INSTALLING GAS PIPING

### 5.1 Installation

Refer to the current **National Fuel Gas Code ANSI Z223.1/NFPA 54** or **CAN/CGA B149.1** installation codes, and local codes for gas piping requirements and sizing. Pipe size running to the unit depends on:

- Length of pipe.
- Number of fittings.
- Type of gas.
- Maximum input requirement of all gas appliances in the residence.

#### Insure that:

- Flexible gas pipe is used (if acceptable by local codes). The gas valve and blower cannot support the weight of piping, leading to blower vibration and damaged components. If rigid piping is used, ensure that the valve supports **NO WEIGHT**
- You plan the installation so that the piping does not interfere with the vent pipe, or the removal of the valve, burner, and serviceable components.
- The Boiler shall be installed such that the gas ignition system components are protected from water (dripping, spraying, rain etc.) during installation and servicing.
- The gas piping is large enough for all the appliances in the home. No appreciable drop in line or manifold pressure should occur when any unit (or combination of units) lights or runs.
- Always use a pipe-threading compound that is resistant to propane (LP) gas solvent action. Use sparingly to all male threads, starting at two threads from the end. Over doping or applying dope to the female end, can result in a blocked gas line.
- **DO NOT TIGHTEN FITTINGS WITHOUT SUPPORTING THE GAS VALVE** as damage to the valve or motor can occur.
- Install a manual "equipment Shut-Off Valve" as shown. Valve must be listed by a nationally recognized testing lab.

Ti100-200

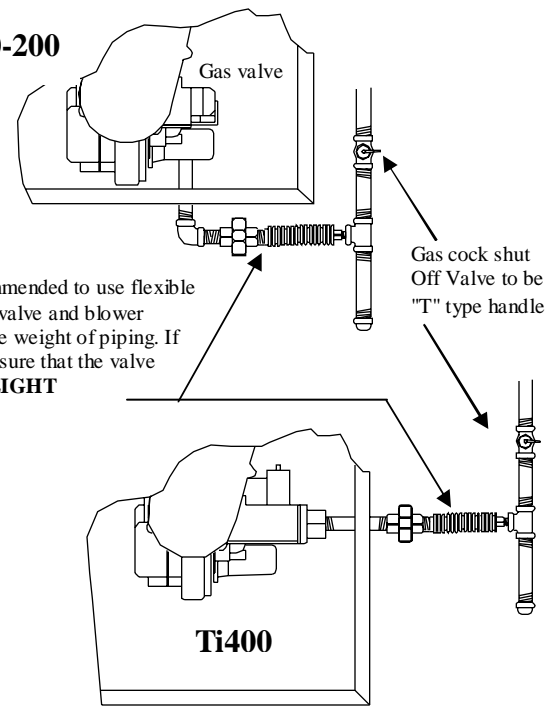

### 5.2 Testing and settings

When running, the line pressure supplying the unit must be **4-9 inches w.c. for Natural gas** installations and **9-12" for Propane** installations. Ensure that the regulator is capable of maintaining this pressure under all operational conditions.



#### **Warning**

***If line pressure exceeds ½ PSI (14 inches w.c.) completely disconnect line to gas valve. This excessive pressure can damage valve, causing a leak resulting in fire or explosion.***

Line pressure should be maintained at 4-9" w.c for Natural Gas and 9-12" w.c for propane while running at maximum rate. Trinity gas valves are equipped with two bleed ports; one is for the Manifold pressure, and the other is for the Line pressure.

The gas valve is equipped with a throttle/input adjustment screw. The input screw "**MUST NEVER BE ADJUSTED**" without verifying proper combustion with a calibrated combustion analyzer.

**Setting Combustion**

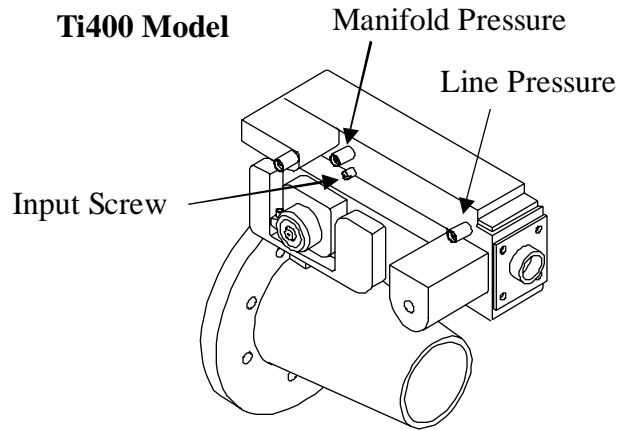
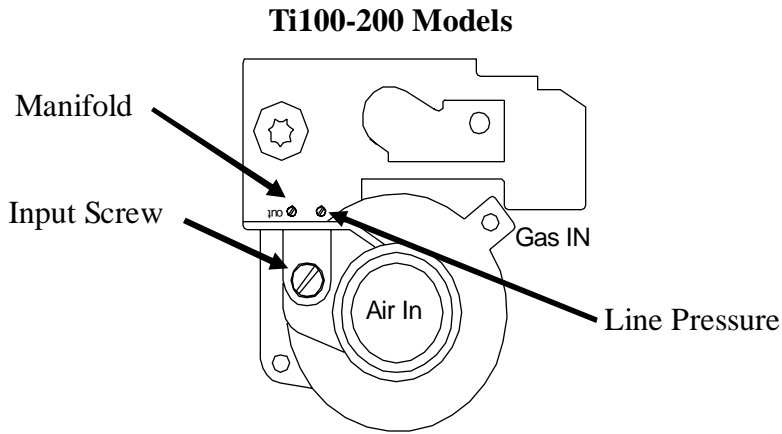

Using a calibrated gas analyzer, check the combustion and compare it with the acceptable requirements. The test should be performed at maximum fan speed (“Gas Input Value”).

**Adjusting Combustion** - Use the input screw to adjust the amount of gas available for combustion. Increasing gas increases CO and CO<sub>2</sub>. Reducing gas decreases CO and CO<sub>2</sub>.

**Normal Range of Combustion Products**  
(At maximum fan speed, 240 for Ti100-200, and 195 for Ti400)

	Natural	Propane
Carbon Dioxide CO <sub>2</sub> %	8-9.5*	9-10.5*
Carbon Monoxide CO ppm	25-175*	25-175*
NO <sub>x</sub> ppm	10-50	10-50

\*Note: On colder days CO<sub>2</sub> should be closer to the lower number, on warmer days it should be closer to the higher number. CO should be highest at the maximum firing rate.

**CO – At maximum fan speed**, the CO reading is the most critical to the safe operation of the boiler. The CO should be no higher than 175 PPM at any condition. If the CO is over 140 PPM, the input should be reduced until the CO is less than 140 PPM or the CO<sub>2</sub> is reduced to 8% (9% for LP Gas). If the CO is over 140 PPM and the CO<sub>2</sub> is less than 8% (9% for LP Gas), contact NTI for assistance.

**CO – At minimum fan speed**, should be checked, and the CO should be less than the reading recorded at high fan speed. The CO<sub>2</sub> at low fan speed must be at least as high as the CO<sub>2</sub> recorded at high fan speed, but not more than 9.5% (10.5% for LP Gas).

**Ti100-200 Input Screw** – Is a multiple turn needle valve. Fully open to close is approximately 17 turns. Typical adjustment for Natural Gas is 0-1 full turns in or out. Typical adjustment for LP Gas is 0-3 full turns in or out.

**Ti Input Screw Adjustment**

Decrease gas  
Turn Clockwise



Increase gas  
Turn counterclockwise



**Ti400 Input Screw** – Is a geared ball valve with a 4 to 1 ratio. Adjusting input screw 4 complete turns will returned the valve to the original location, 2 turns from fully open will completely close the valve. Typical adjustment required is 0-1/4 turns in or out.

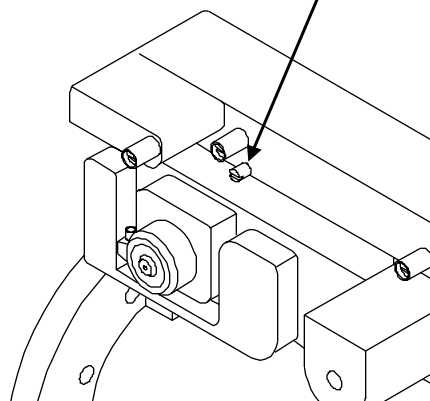
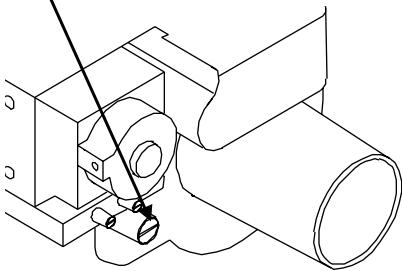

**IF FOR ANY REASON THE INPUT SCREW IS ADJUSTED, A “COMBUSTION ANALYZER” MUST BE USED TO ENSURE SAFE AND PROPER OPERATION.**

**Caution** The Trinity is tested with Natural Gas having a heating value of 1020 BTU per cubic foot. For areas with lower heating values, a combustion test is required to obtain optimum operation.

## 6.0 HEATING SYSTEM PIPING

### *Warning / Hard Water*



*This boiler must have adequate water flowing through it whenever the burner is on. Failure to do this will damage the unit and void the warranty. Water with a total hardness greater than 6 Grains/gallon may result in heat exchanger failure. Treat with Fernox Protector F1, included in boiler package (NTI Part Number: 83448).*

### *Warning for all Systems*



*All systems old and new must be flushed to remove sediment, flux, filings, etc. Failure to do so will seriously damage the boiler, voiding warranty. Clean with Fernox Cleaner F3 (NTI Part Number: 83449).*

### *Warning for all Systems*



*The boiler fittings can't support any weight. Support all of the plumbing system externally.  
Do not apply torque to the boiler fittings. Hold the fitting when installing, otherwise damage to the unit will occur.*

**Caution:** This boiler is designed to operate in residential and commercial heating systems, and is not intended for:

1. Outdoor installations, or unheated spaces, which can cause freezing.
2. Process heating of potable water, or any other fluids.
3. Un-pressurized, and gravity feed heating systems.
4. Heating systems with very low pressures or flow.

### **IMPORTANT**

1. Understand and follow the plumbing requirements provided in this section.
2. Keep serviceability in mind when installing plumbing around the boiler cabinetry.
3. Install fittings that will allow the system to be flushed if needed during annual check-ups.
4. Add inhibitor, Fernox Protector F1 (NTI Part Number: 83448), to the system water to help prevent limestone and magnetite deposits and galvanic corrosion. Bottle provided will treat an average 100-liter (26 US gallon) system.

**The Trinity boiler comes in two versions, Heating and Combi.**

**Heating Version** – The standard heating version is designed to operate in a hydronic heating system and can operate with an indirect water heater.

**Combi Version** – This special version is equipped with internal components to provide hydronic heating and domestic hot water heating. See Sections 6.1 and 6.3. (Not available on Ti100 & Ti400 Models)

**6.1 Primary Loop Plumbing**

**Circulating Pump** Due to the Trinity design, the boiler is more restrictive than a conventional boiler, thus greater consideration must be given to the capabilities of the circulating pump(s) in the primary-loop (including the Indirect Hot Water heater loop-pump).

The following is a listing of the recommended circulators.

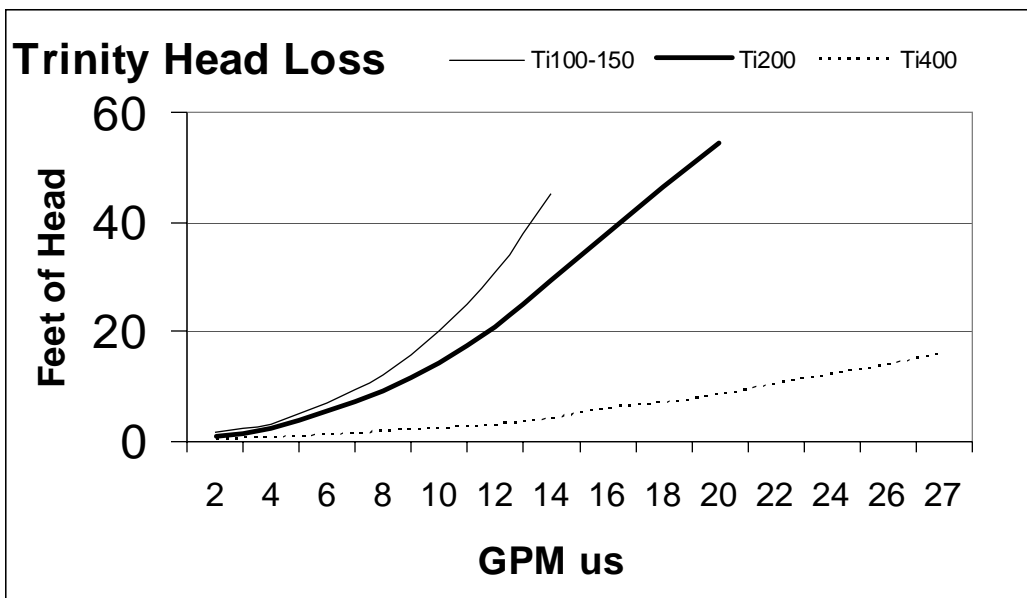

Model	Restriction Head Loss	Recommended Pipe Size	Minimum Flow (us GPM)	Max. Temp. Rise	Minimum Primary Pump Size		
					B&G	Grundfos	Taco
100	7' at 6 GPM	1"	4.5	45°F	NRF-22*	UP 15-58*	008*
150	7' at 6 GPM	1"	6	45°F	PL-30	UP 26-64	009**
200	10' at 8 GPM	1-1/4"	8	45°F	PL-36	UP 26-99	0011
400	10' at 20 GPM	1-1/2"	13	57°F	PL-36	UP 26-99	0011***

*Notes:*

\*Must use at least minimum pump size specified for Ti150 if installation requires the use of a flow switch.

\*\*The Taco 009 circulator will flow more through the Ti100-150 boilers than the Taco 0010 circulator.

\*\*\*Recommend using a Taco 0013 for indirect circulator on Ti400.

**Relief Valve:** A 30PSI Relief Valve is provided with the system, and it is to be mounted as shown in the diagram. Ensure that the discharge of the pressure relief is piped to a location where steam or water won't cause personal injury or appliance and property damage. The Ti100-150ASME and Ti400 have a maximum operating pressure of 80PSI (145PSI on some models, check the ASME plate affixed to the heat exchanger), therefore a relief valve with a higher relief setting can be used.

**Boiler Venting:** Hot water boilers are designed to operate with airless water in the system. An Air Scoop, installed as shown in the following diagrams, must be installed to remove air as it circulates through the boiler. It is recommended that an additional Air Scoop be used in the secondary plumbing. If air continues to be a problem an air scrubber must be used (recommend Spirovent # VJR 100TM for Ti100-150, VJR 125TM for Ti200, and VJR 150TM for Ti400. Use a minimum 1-1/4" primary-loop plumbing with model VJR 125TM and 1-1/2" primary-loop plumbing with model VJR 150TM).

### Low Water Cutoff / Flow Switch:

- **Model Ti400** A certified Flow Switch is installed inside the boiler cabinet on the boiler outlet pipe. Check with local authorities for requirements of additional safety equipment such as a LWCO.
- **Models Ti100-200** A certified LWCO or Flow Switch is not provided in the package, however one is to be field installed in any application where the boiler is located above the radiation or where local authorities require it. NTI recommends installing a LWCO or flow switch to prevent the boiler from firing without water in the heat exchanger. Ensure that the water line of the "Low Water Cutoff" is at least 6" above the top of the boiler.
- It is recommended that the LWCO be situated so that it can be tested without removing water from the boiler. Tri-cocks and a gauge glass are highly recommended.
- NTI recommends against the installation of isolation valves between the LWCO and the boiler.
- Use the normally open contacts of the LWCO to break line voltage before being supplied to the boiler. Circuit is 120 Volts, 12 Amps.
- Contact NTI for proper installation and wiring of a Certified Flow Switch for Trinity Models Ti100-200. NTI recommends "McDonnell & Miller" flow switch model FS8-W installed in a 1"-diameter line. (See recommended pump chart on previous page.)

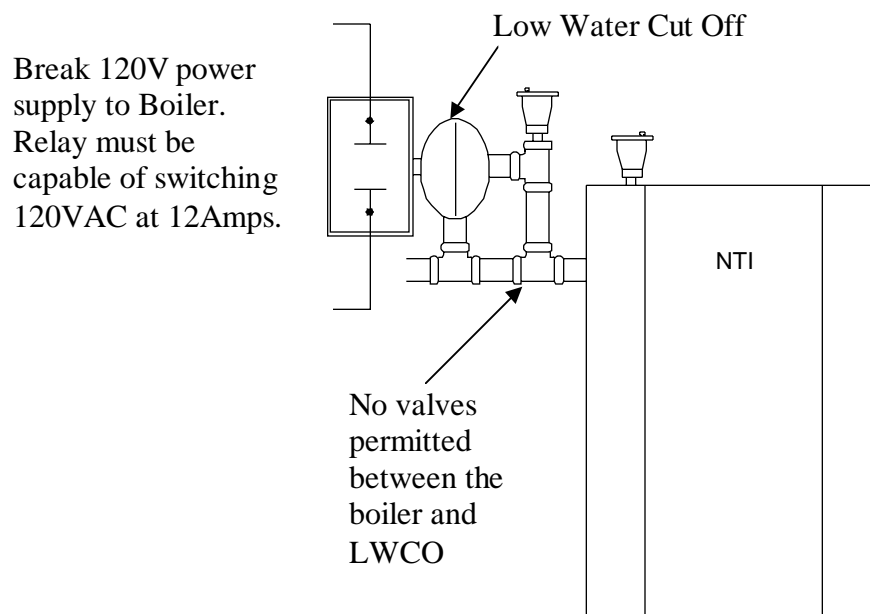

**The Trinity boiler is to be used only in a Primary / Secondary pumping system. This is to avoid cycling problems in systems that have poor flow, or heating zones with very small capacities. The primary loop system must be used in all cases, regardless of the configuration of the secondary system design.**

**Flow:** The Trinity boiler must have water flow going through the boiler whenever the burner is on.

**CAUTION: DAMAGE WILL OCCUR IF THE BOILER IS FIRED WITH NO WATER IN IT, OR REPETITIVE NO FLOW OPERATIONS, WHICH WILL VOID THE WARRANTY.**

## Primary Loop For Heating Model

Quantity and location of shutoff valves, and drains, are at the discretion of the installed.

**Ti 100-150**  
(non ASME)

### Legend

- A- Back flow preventor
- B- Fill valve (set at 12 psi)
- C- Diaphragm expansion tank
- D- Cast Iron Air scoop, for excessive air use Spirovent (see page 12).
- E- Automatic air vent
- F- Relief valve (set at 30 psi)
- G- Pressure gauge
- H- Heating pump (see size recommendations in Sec.6.1) Wired to terminals C<sub>1</sub> - L<sub>2</sub>
- I- *Optional Indirect pump* (see recommendations in Sec.6.1) Wired to terminals A<sub>p</sub> - L<sub>2</sub>
- J- *Optional Indirect Water heater*
- K- Swing check valve.
- L- Ball Valve
- M- Boiler Drain
- N- Boiler inlet connection (warm)
- O- Boiler outlet connection (hot)
- P- External Combi Manifold #82470-1

All piping must be secured to wall for support

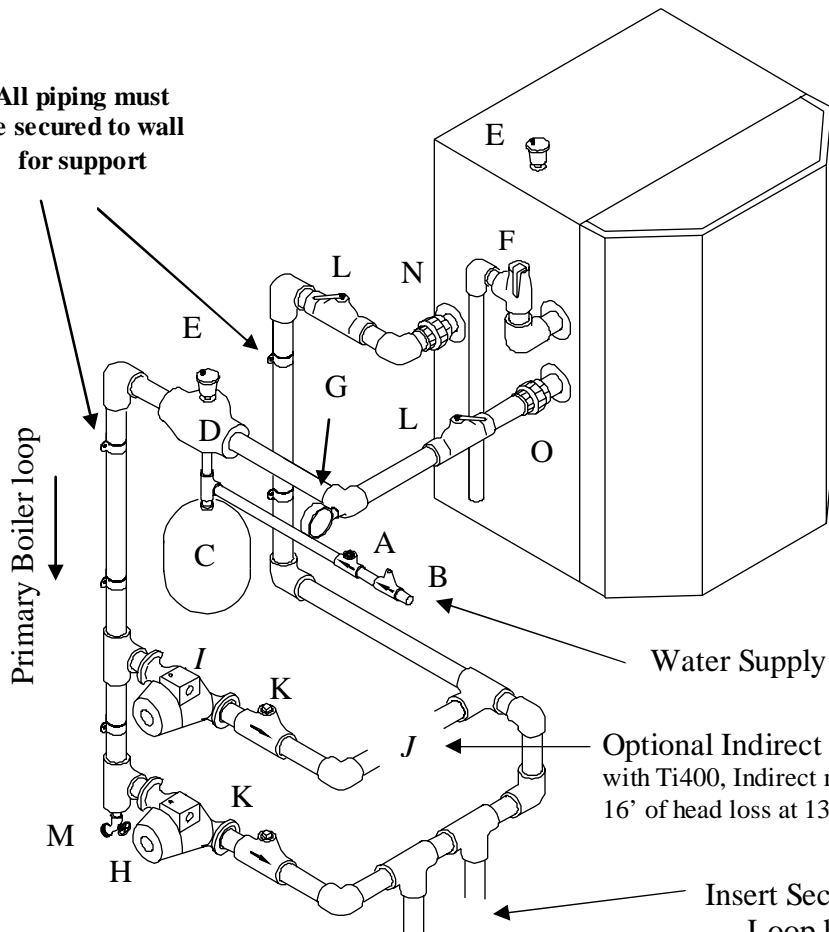

Optional Indirect (For installation with Ti400, Indirect must have less than 16' of head loss at 13usgpm.)

Insert Secondary-Loop here.  
See pages 16-17

## Models Ti100-400ASME

Relief valve location. All other piping is same as Ti150

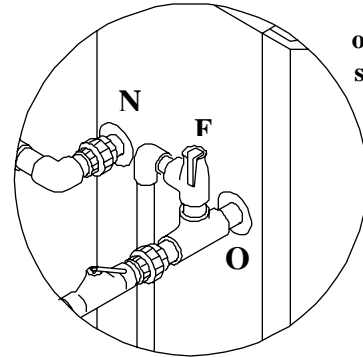

Quantity and location of shutoff valves, and drains, are at the discretion of the installer.

## Primary Loop For Combi Model Only (Ti150C & Ti200C models only)

All piping must be secured to wall for support

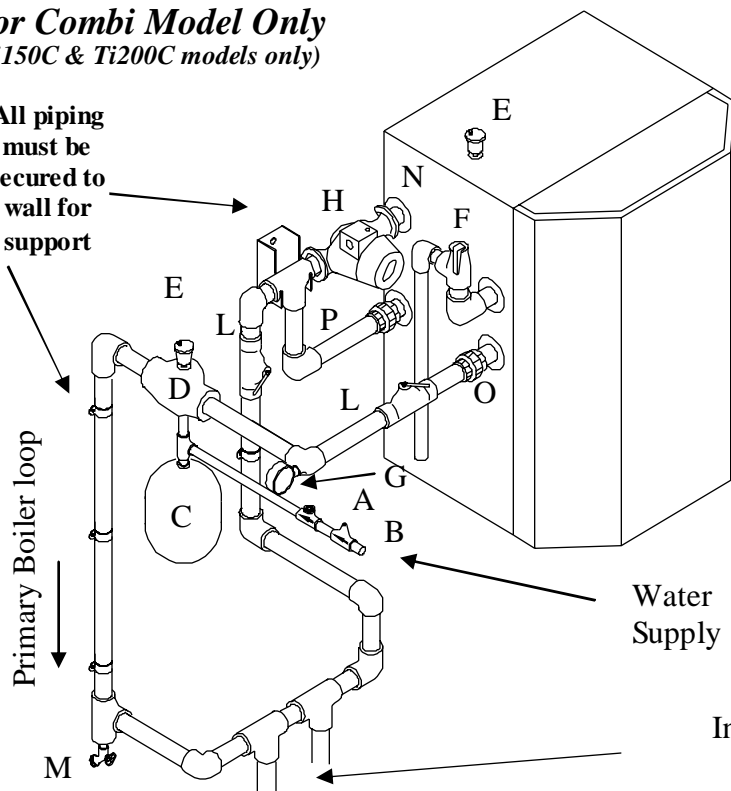

Insert secondary Loop here.  
See page 16-17

## 6.2 Secondary Loop Heating System

The following are typical piping systems. It is the responsibility of the installing contractor to determine which system best meets the need of the installation. Contractor modifications to these instructions may be required, based upon existing piping and system design.

### 6.2.1 Multiple Zones using Zone Valves

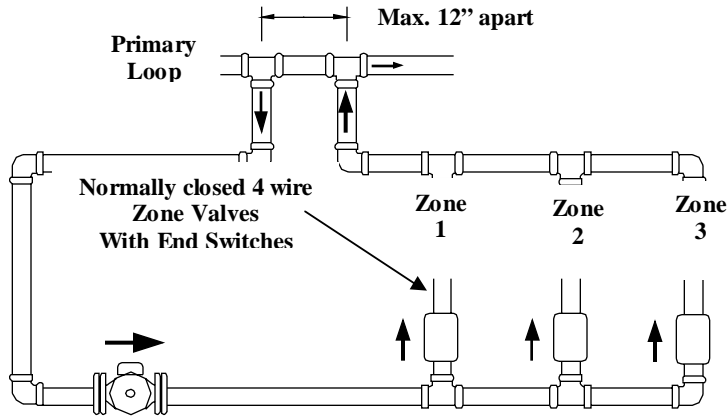

**See figure**  
7.2.1 "Multiple 4 wire Zone Valves"  
for wiring  
7.2.2 "Multiple Zones with Taco Valve controller"

### 6.2.2 Multiple Zones using Pumps

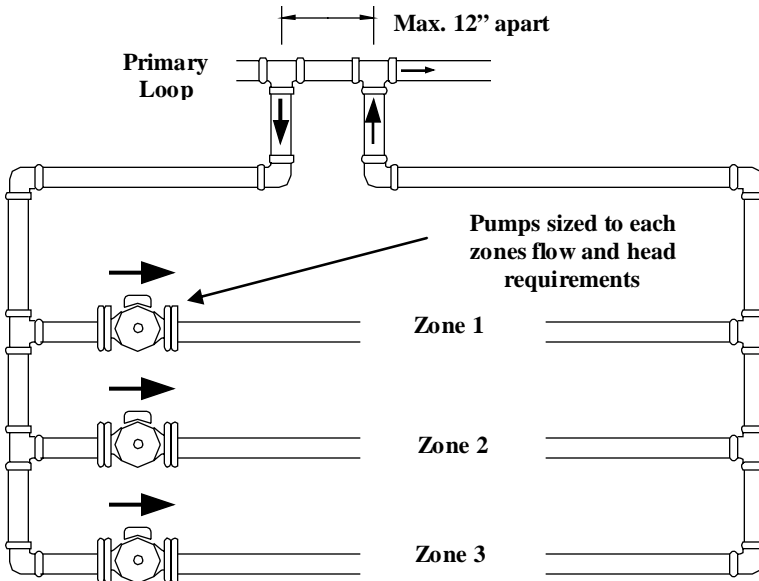

**See figure**  
7.2.3 "Multiple Zones using pumps  
and pump controller"  
Installer may require throttling and check  
valves to correctly regulate the system

### 6.2.3 Multiple Zones with Different Temperatures

#### Using pumps and tempering valves

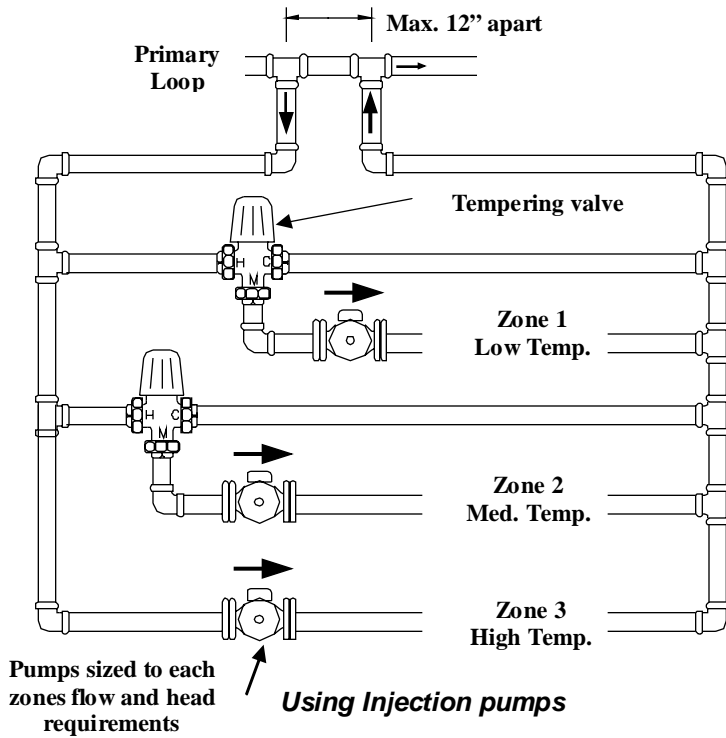

See figure

7.2.3 "Multiple Zones using pumps, and pump controller"

By setting the tempering valves to different settings, multiple temperatures can be obtained.

Installer may require throttling and check valves to correctly regulate the system.

Other configurations may work, but under no circumstances can a mixing valve be placed in the primary loop as overheating of the boiler could occur.

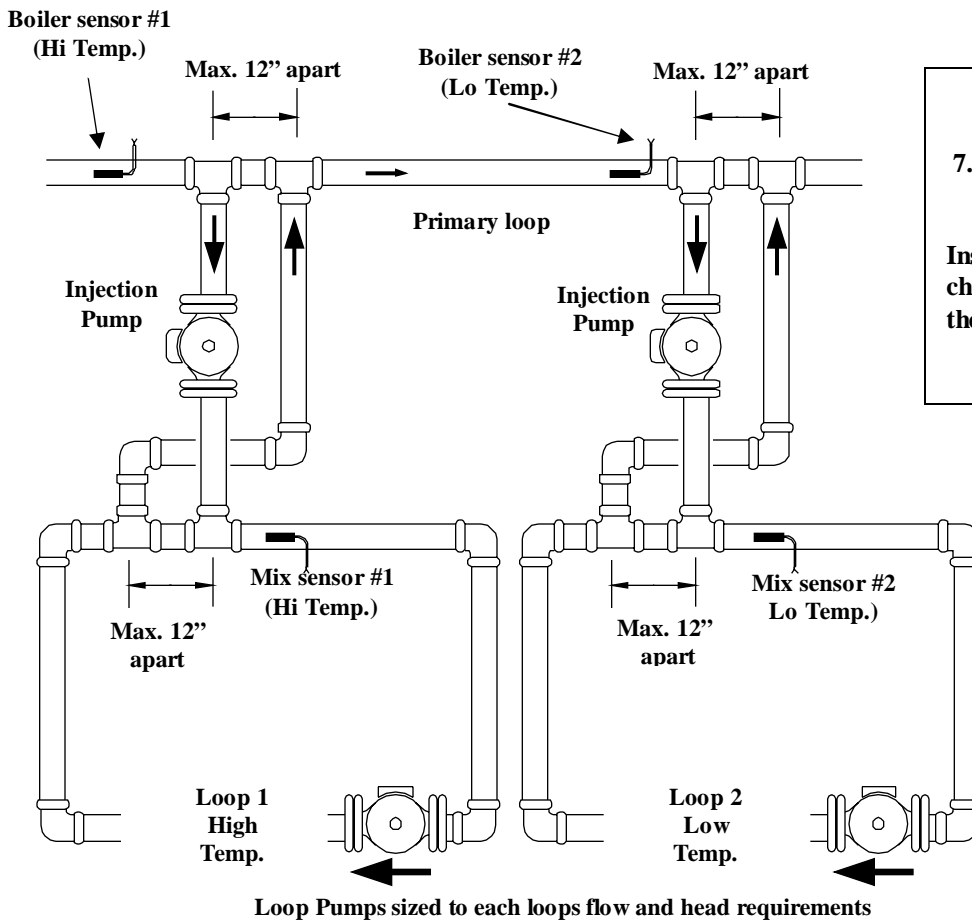

See figure

7.2.4 "Multiple temperature Zones using injection pump"

Installer may require throttling and check valves to correctly regulate the system

## Primary Loop For multiple boilers (Non-Combi's only)

Note: See page 15 for location of expansion tank and other components

Insert secondary Loop here. See pages 16 & 17

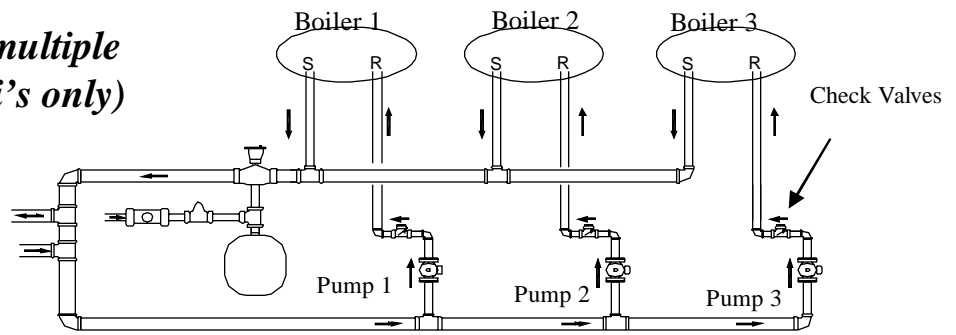

### 6.3 Domestic Combi System

((OPTIONAL on Ti150 and Ti200 Only))

"The Trinity Combi is designed for installations where there is a limited DHW demand, such as smaller apartments and condos. In applications where there is a greater DHW demand we recommend the use of our heating model boiler in conjunction with an Indirect Water Heater."

The Combi has all the features of the standard heating version plus; External Combi Manifold, diverting valve, plate heat exchanger & flow switch. Note: The installer is required to install the pump flange (included in Combi kit) onto the boiler return pipe prior to installing the boiler; the bolts must be inserted into the flange prior to installing the flange.

A	Heating System Supply (hot)
B	Heating System Return (cool)
C	Heating & Combi Circulator
D	No elbows within 2" of flow switch
E	3 way diverting valve
F	Domestic Water in (Cold)
G	External Combi Manifold #82470-1
H	Flow switch MUST be in vertical position, inlet down.

#### COMBI Sequence of operation

When water flow greater than .5 GPM passes through the flow switch, it closes a contact to terminals A-C on the Sentry 2100 controller. The boiler is immediately energized (if not already on), the 3-way diverting valve moves to the domestic hot water position "A", and the circulator is energized. Hot water is circulated through the plate heat exchanger. The flame is modulated to maintain the "LO" setting on the Sentry control. The Sentry uses the boiler thermister to read the temperature of the boiler water. Space heating is not provided during a call for domestic.

Note: Locations of plumbing connections are not as shown, refer to labels on boiler, contact NTI with any questions.

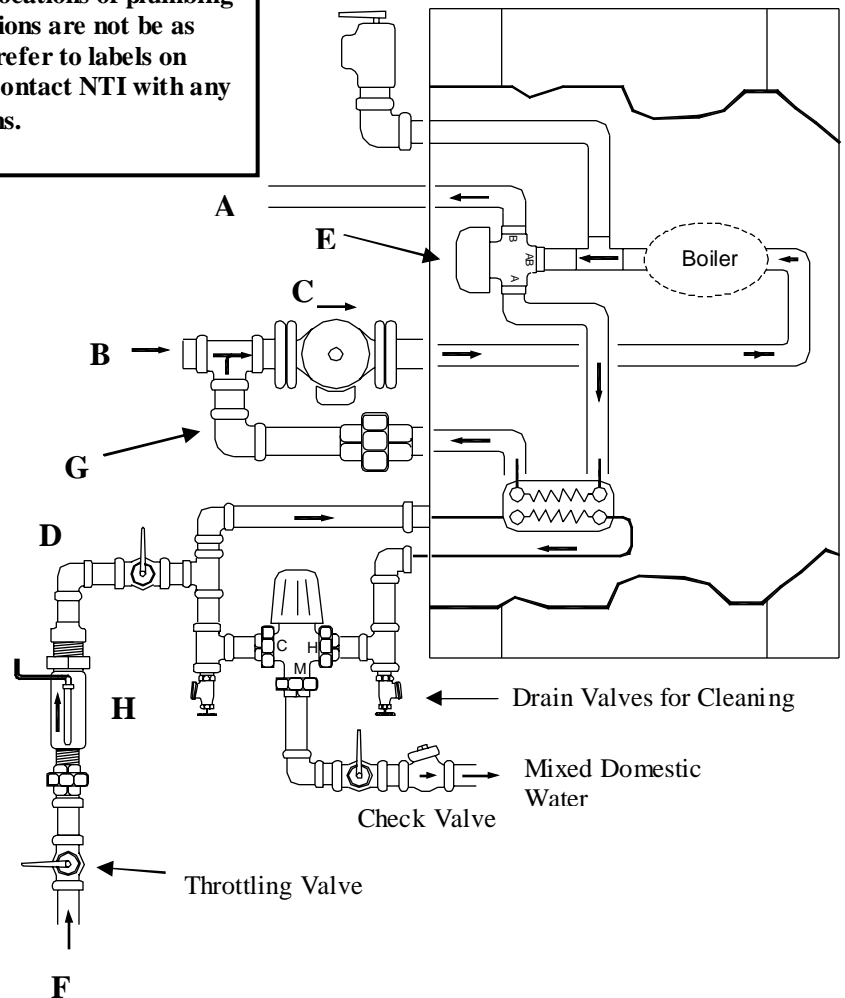

#### For the state of Massachusetts

Combi must be field equipped with 150 PSI relief valve as shown (not provided)

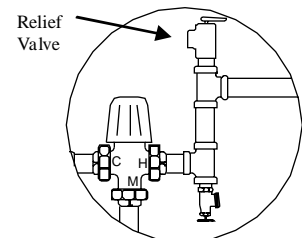

To combat delays in domestic hot water delivery, normally associated with on-demand hot water heaters, Trinity Combi boilers are equipped with an optional “Storage Mode” feature, which when turned on via the Sentry menu, maintains hot domestic water at the plate heat exchanger for 1 to 24 hours after the latest DHW call ended (*Sentry menu option StO is adjustable from OFF to 1 to 24 hours, factory setting is 4*). The feature is not active when turned OFF, when turned on it is interrupted by a DHW or heating demand.

**Anti-Scald Valve** A Sparcomix AM101-US-1 is provided with your package. This valve regulates the water temperature leaving the plate heat exchanger, and must be used in every instance. The dial can be set to the desired temperature required. Consult the Honeywell manual *SD/IS150* for detailed instructions and settings. (*Note: the valve must be set to a supply temperature of not more than 120°F. It is the responsibility of the installer to set the valve and remove the dial.*)

**Hard Water** Hard water conditions will cause the components of this appliance to form scale and impede the normal operation of the unit. Water with hardness higher than 50 ppm Calcium carbonate must incorporate a “Water Softener” prior to entering the appliance. Plugging of domestic system by scaling or accumulation of dirt is not the responsibility of NY Thermal Inc., and suitable steps shall be taken to avoid it.

**Cleaning** Secespol brazed plate heat exchangers operate with high turbulence flow, even at low flow rates. This high turbulence keeps small particles in suspension minimizing fouling and scaling. However, in some applications the fouling tendency can be very high, e.g. when using extremely hard water at high temperatures. In such cases it is always possible to clean the exchanger by circulating a cleaning liquid. Use a tank with weak acid, 5% phosphoric acid or, if the exchanger is frequently cleaned, 5% oxalic acid. Pump the cleaning liquid through the exchanger. For optimum cleaning, the cleaning solution flow rate should be a minimum of 1.5 times the normal flow rate, preferably in a back-flush mode. After use, do not forget to rinse the heat exchanger carefully with clean water. A solution of 1-2% sodium hydroxide (NaOH) or sodium bicarbonate (NaHCO<sub>3</sub>) before the last rinse ensures that all acid is neutralized. Clean at regular intervals.

**Combi Limitations** The Trinity Combi produces domestic hot water on demand, therefore the boiler can only provide hot water up to a rate equal to it’s capacity to burn fuel. The following tables indicate the maximum domestic hot water flow rate at various inlet and outlet water temperatures.

**Procedure for Setting up Domestic Hot Water** If the combi boiler is being installed in an application that uses municipal water, often the pressure is high enough to generate flow rates at the faucets that will exceed the boilers capacity to heat it. See the following tables to determine what flow can be expected at various inlet and outlet water temperatures.



**Warning**

**If the Anti-Scald Valve is not installed to the Honeywell Sheet SD/IS150, and this manual, operation may supply SCALDING hot water to the occupants.**

**Table 1: Ti150C Flow rates (flow rates in usgpm)**

		Inlet Water Temperature (deg. F)						
		40	45	50	55	60	65	70
Outlet Water (F)	110	3.9	4.2	4.5	4.9	5.4	6.0	6.7
	115	3.6	3.9	4.2	4.5	4.9	5.4	6.0
	120	3.4	3.6	3.9	4.2	4.5	4.9	5.4
	125	3.2	3.4	3.6	3.9	4.2	4.5	4.9
	130	3.0	3.2	3.4	3.6	3.9	4.2	4.5
	135	2.8	3.0	3.2	3.4	3.6	3.9	4.2
	140	2.7	2.8	3.0	3.2	3.4	3.6	3.9

**Table 2: Ti200C Flow rates (flow rates in usgpm)**

		Inlet Water Temperature (deg. F)						
		40	45	50	55	60	65	70
Outlet Water (F)	110	5.1	5.5	6.0	6.5	7.2	8.0	9.0
	115	4.8	5.1	5.5	6.0	6.5	7.2	8.0
	120	4.5	4.8	5.1	5.5	6.0	6.5	7.2
	125	4.2	4.5	4.8	5.1	5.5	6.0	6.5
	130	4.0	4.2	4.5	4.8	5.1	5.5	6.0
	135	3.8	4.0	4.2	4.5	4.8	5.1	5.5
	140	3.6	3.8	4.0	4.2	4.5	4.8	5.1

To avoid having too much flow at your faucets use the shut off valve after the mixing valve to limit the overall flow of domestic hot water. Follow these instructions to achieve the best results with your Combi boiler:

1. Open shut off valve fully.
2. Turn the dial on the mixing valve to the desired setting (*being careful not to exceed 120°F or a dial setting greater than 2*) and adjust LO setting accordingly.
3. Create the maximum amount of DHW flow that is likely to occur on a regular basis. (Usually tub faucet, or choose two other faucets)
4. Allow the boiler to reach steady state, and then throttle the shut-off valve until the hot water exiting the plate heat exchanger is warmer than the mixed water exiting the mixing valve. Ensure the boiler is firing at the maximum rate, if not increase the LO setting and repeat this step. (It is beneficial to keep the LO setting as low as possible to limit short cycling and maintain efficiency)

## 7.0 WIRING

All wiring must be in accordance with the Canadian Electrical code, CSA C22.2, and any applicable local codes. Ensure that the wiring is in accordance with this manual.

**Contact capacity of outputs C<sub>1</sub> or A<sub>p</sub> is 3 running Amps with a maximum inrush of 6 Amps.** If the capacity of the pumps is in excess of these maximums, you must either use a pump controller, or isolation relay to energize the pumps.

## 7.1 Simplified Wiring Connections

### Heat and Indirect Wiring

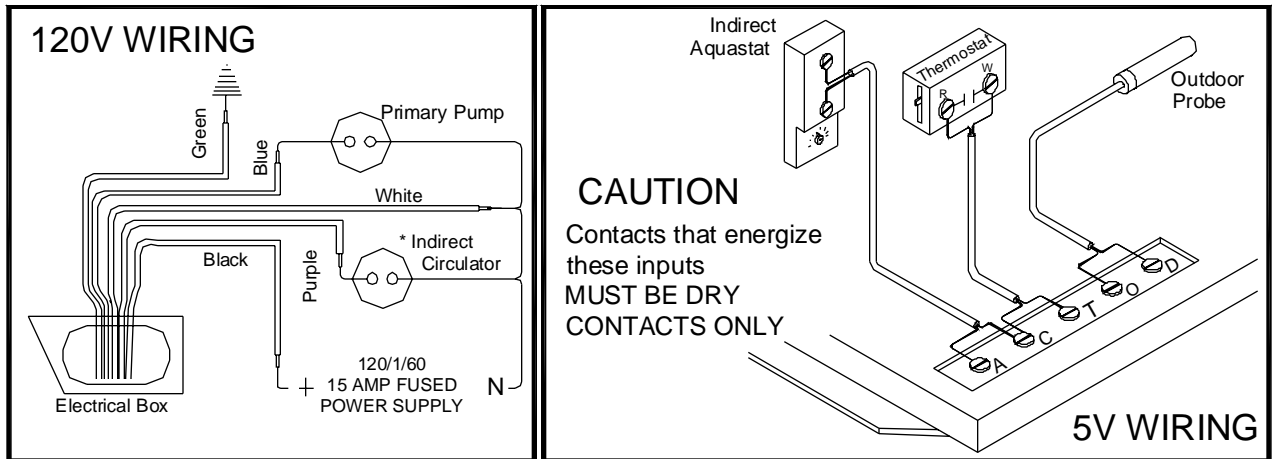

### Combi Wiring

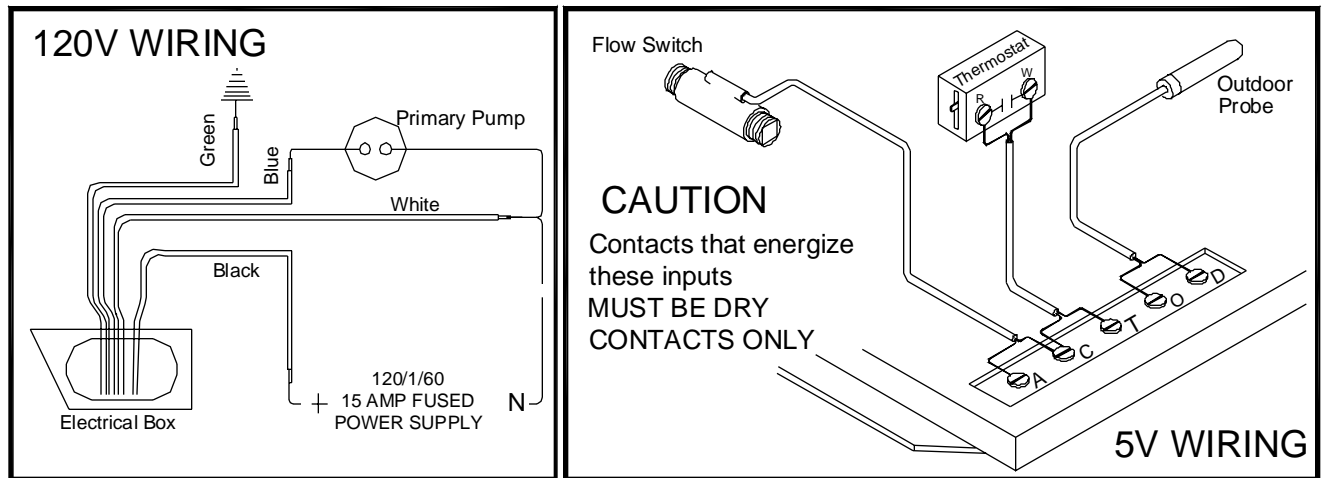

The boiler must be electrically grounded in accordance with the National Electrical Code ANSI/NFPA 70, or local codes, and/or the Canadian Electrical Code CSA C22.1.

**Warning!!! A bad installation could ruin the Sentry Board and void your warranty.**

- Before providing 120 Volts to the boiler, do a continuity check between all wires and ground to make sure that there are no electrical leaks that could damage the board.
- Before providing 120 Volts to the boiler, do a polarity check of the line and neutral wires, line must be connected to black and neutral must be connected to white.
- Do not use magnetic tip screwdriver near the Sentry board.
- Verify that the wires connected to the Sentry **TC and AC terminals are not grounded**, or have any voltage applied to them, or voltage to ground (dry contact closure only).
- Ensure that the probe wire is not damaged.
- Caution: Label all wires prior to disconnecting them when servicing controls. Wiring errors can cause improper and dangerous operation



**Warning**

**Maximum current of blue wire (C<sub>1</sub>) is 3 Amps, with all pumps running. Current in excess of 3 Amps, may damage the board, and void the warranty.**

## 7.2 Advanced Wiring Systems

### 7.2.1 Multiple 4 wire Zone Valves

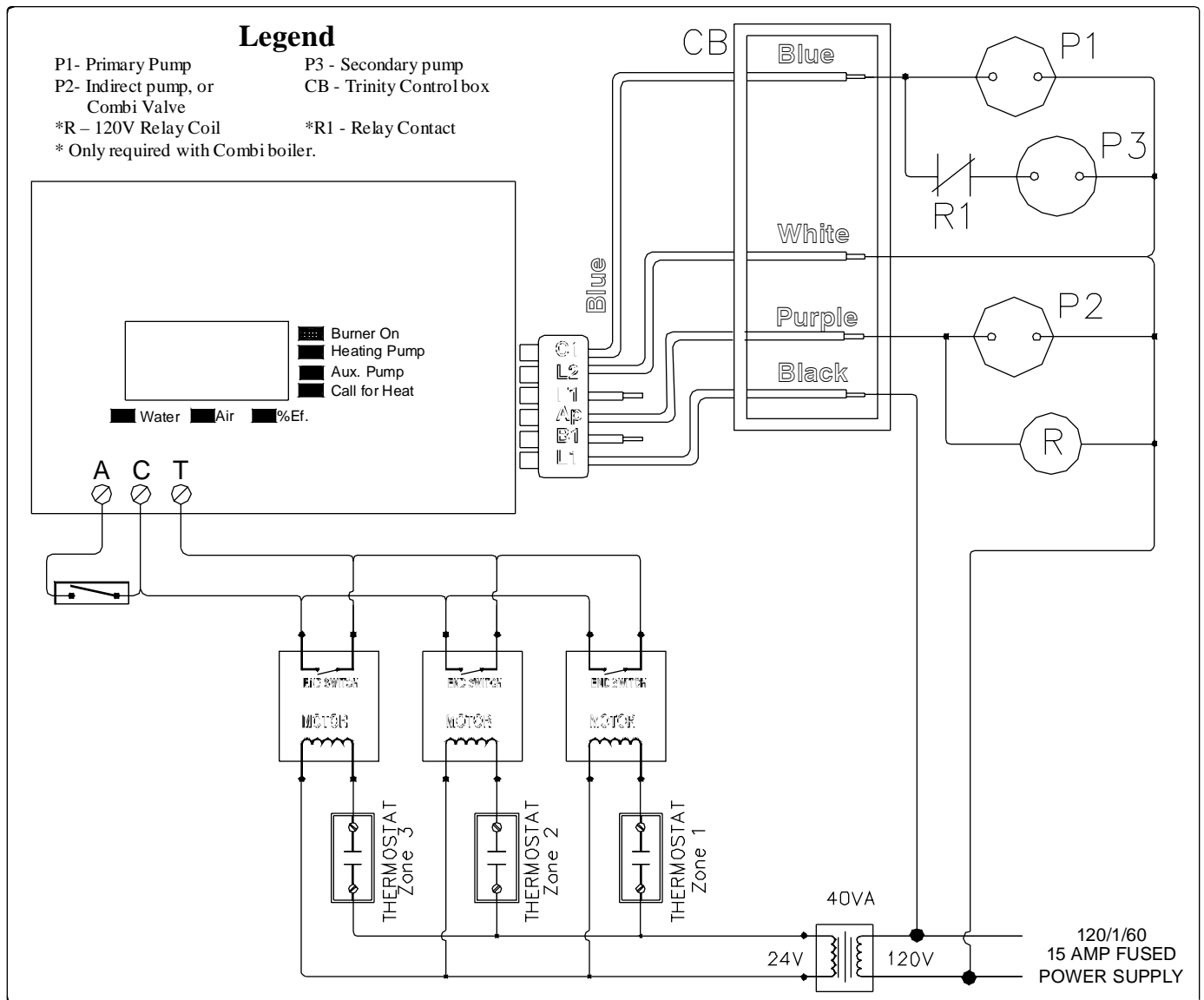

The basic multiple zoned system uses normally closed four (4) wire zone valves. This wiring system is used with the piping as described in Section 6.2.1 “Multiple Zones using Zone Valves”.

#### Operation

Room thermostat closes circuit to zone valve motor, thus opening the valve. When the valve is opened, the end switch closes the circuit between terminals T-C on the Sentry control. The Sentry 2100 provides power to the primary pump and secondary pump via (C<sub>1</sub>), once these pumps are on, it turns on the burner.

Once the room thermostat is satisfied, it breaks power to the motor, which opens the end switch, and the T-C circuit. The Pumps and burner turn off.

## 7.2.2 Multiple Zones with Taco Valve controller

(Models ZVC403 to ZVC 406)

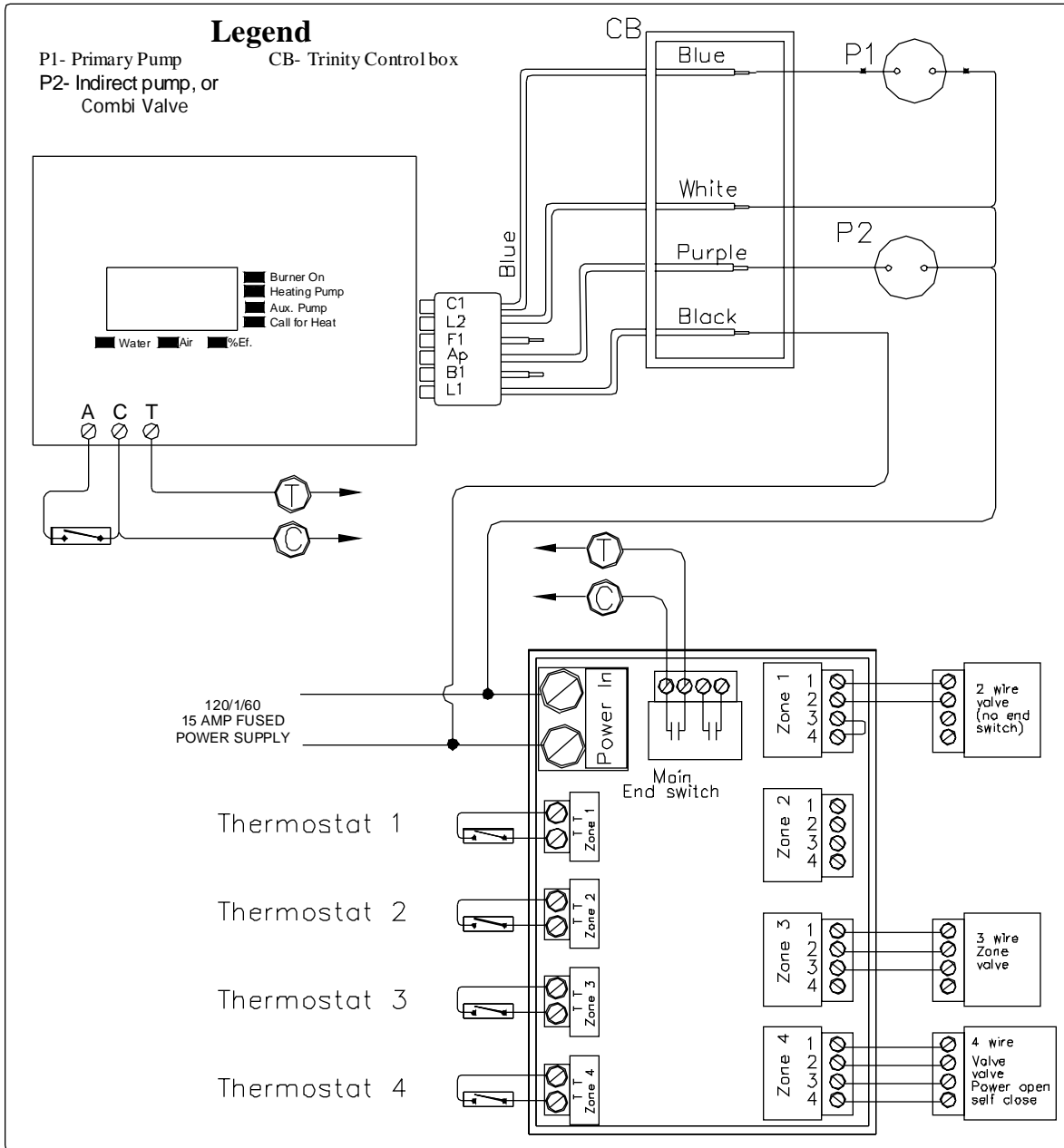

The basic multiple zoned system using normally closed 2 – 3- or 4 wire Taco zone valves. This wiring system is used with the piping as described in Section 6.2.1 “Multiple Zones using Zone Valves”.

### Operation

Room thermostat closes circuit to TT terminals Taco ZVC403 to ZVC 406 zone controller. The controller energizes the appropriate zone valve and closes the circuit between terminals T-C on the Sentry control. The Sentry 2100 provides power to the primary pump and secondary pump via (C1), once these pumps are on it turns on the burner.

Once the room thermostat is satisfied, it breaks power to the motor, which opens the end switch, and the T-C circuit. The Pumps and burner turn off.

### 7.2.3 Multiple Zones Pump controller

(Models Taco SR504, Argo ARM 861 Series)

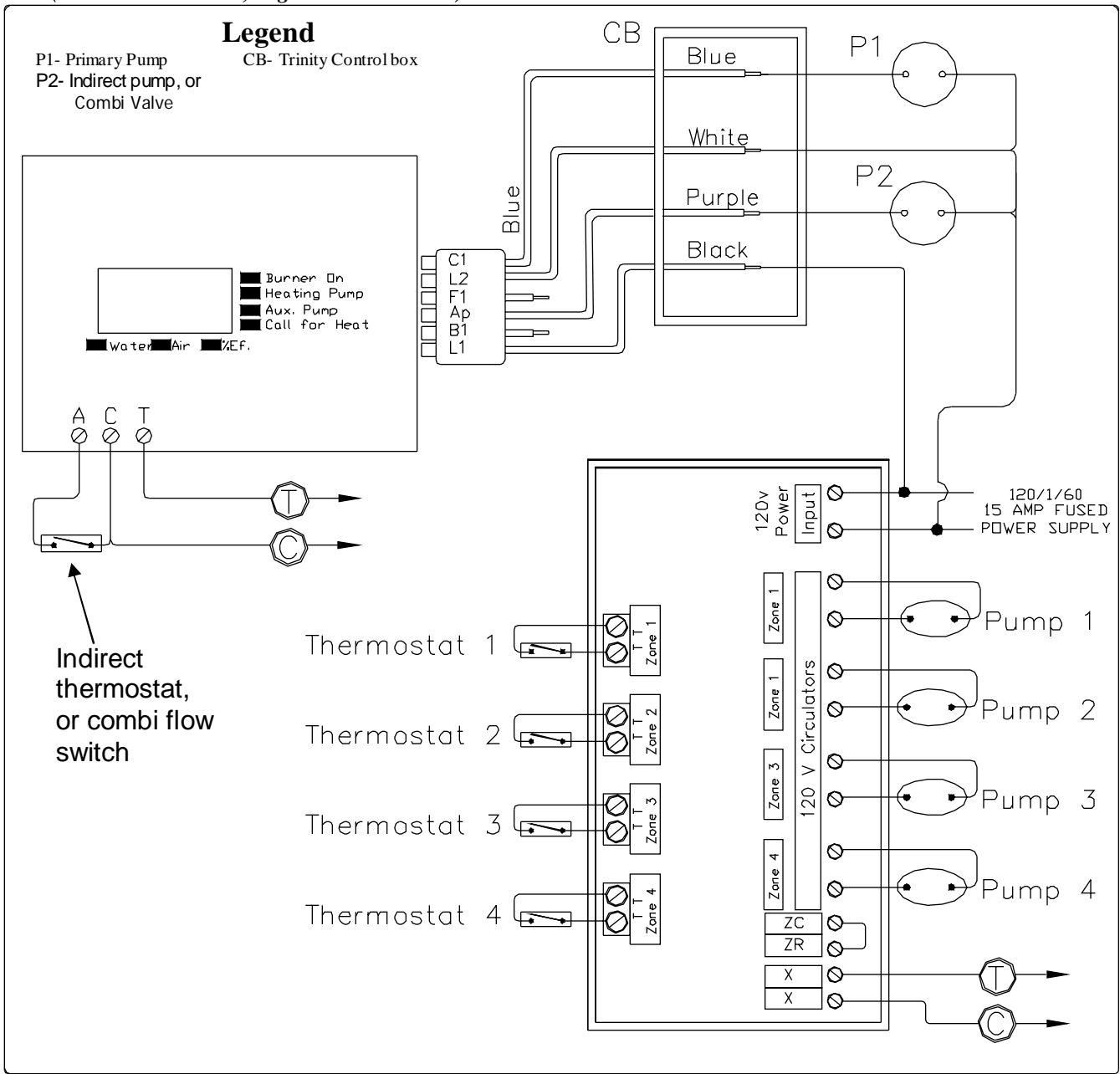

The basic multiple zoned system using circulating pumps. This wiring system is used with the piping as described in 6.2.2 Multiple Zones using Pumps and 6.2.3 Multiple Zones with different temperatures.

#### Operation

Room thermostat closes circuit to TT terminals of the pump controller. The controller energizes the appropriate circulating pump and closes the circuit between terminals T-C on the Sentry control. The Sentry 2100, provides power to the primary pump (C<sub>1</sub>), once the pump is on, it turns on the burner.

Once the room thermostat is satisfied, it breaks power to the TT terminal of the pump controller, which opens the X-X contacts, which opens the T-C circuit. The Pumps and burner turn off.

## 7.2.4 Multiple Temperature Zones with Injection Pumps

(Models Taco SR504, Argo ARM 861 Series And Tekmar 356 controller)

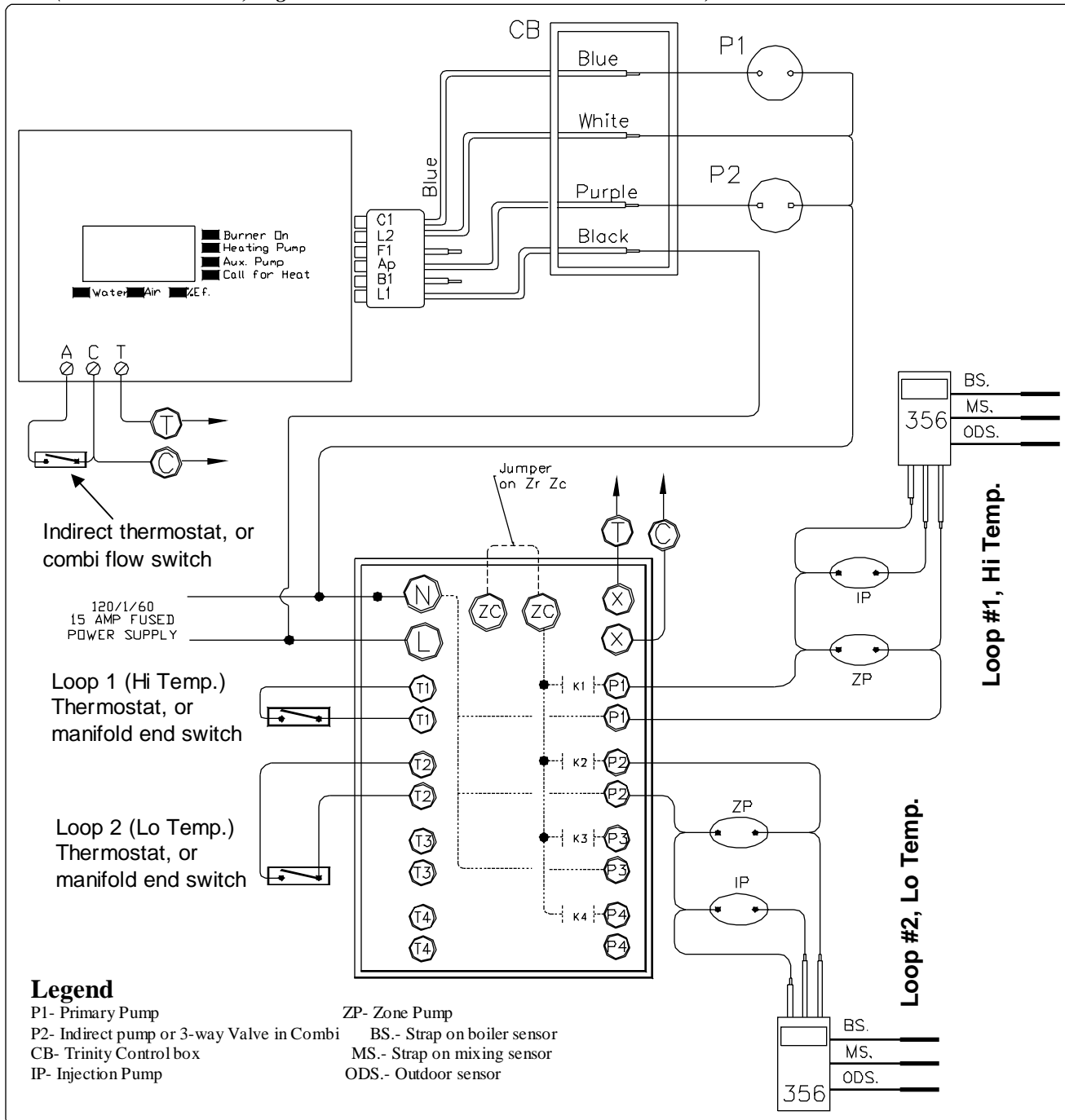

This wiring system is used with the piping as described in 6.2.3 Multiple Zones with different temperatures ((Using Injection pumps))

### Operation

Room thermostat or the end switch of a zoned manifold closes the circuit to TT terminals of the pump controller. The pump controller then:

1. Sends 120 volts to the zone pumps (which circulates mixed water throughout the loop).
2. Sends 120 volts to the injection pump, through the 356 Tekmar controller.
3. Closes the circuit between terminals T-C on the Sentry control. The Sentry 2100 provides power to the primary pump via (C<sub>1</sub>), once the pump is on, it turns on the burner.

The 356 controller reduces or increases the speed of the injection pump, depending on the temperature at the “Mix sensor”.

Once the room thermostat is satisfied, it breaks power to the TT terminal of the pump controller, which opens the X –X contacts, which opens the T-C circuit. The Pumps and burner turn off.

In an injection system, it is important to understand the effect of flow and temperature set points. It may be necessary to program the Sentry controller higher than the desired Mix temperature of the Hottest Loop.

Consult the Tekmar installation manual for detail installation and operation of this control.

### 8.0 SENTRY 2100 CONTROLLER

**(Caution: Sentry controller used on Ti400 is different then the Sentry controller used on Ti100-200 models. The T4.1 controller can only be used on Ti400's, while the T2.2 controller can only be used on Ti100-Ti200's)**

**The Sentry controller is the central controller for the Trinity boiler. The Sentry handles all the combustion logic, together with the energy management functions. The Sentry 2100 operates in two different modes, reset or conventional. The mode is automatically determined by the presence of the outdoor sensor. When the Sentry 2100 detects the presence of the outdoor sensor the controller will operate in Reset Mode. If the outdoor sensor is not installed, the controller will operate in Conventional Mode. If outdoor sensor is connected after start-up boiler must be powered off and on.**

### 8.1 Sentry 2100 Display

The following describes the meaning of the lights on the Sentry controller.

**Green Lights:**

- Burner/Bruleur** = Indicates that the ignition system is activated
- Circ.** = Indicates that the heating pump is energized
- Circ. Aux.** = Indicates a call for DHW, and Indirect pump or 3-way valve is activated.
- Thermostat Demand** = Indicates that terminals T-C are closed, initiating a call for heat.

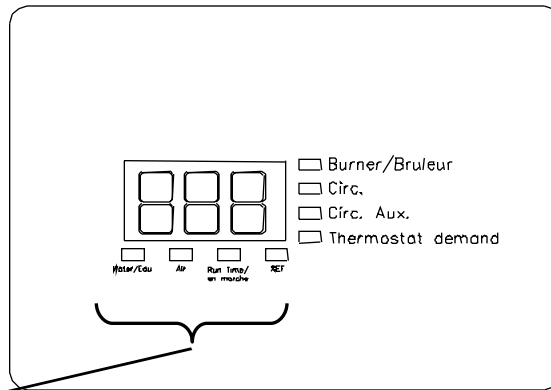

**Water Temp**= When illuminated, indicates that the display is showing boiler water temperature.

**Air** = If the air sensor is being used. When illuminated, indicates that the display is showing outdoor air temperature.

**Gas Input Value**= When illuminated, indicates the current input level (46-240 on Ti100-150, 40-240 on Ti200, 35-195 on Ti400). See Chart to determine input.

**DHW Temp.** = When illuminated, indicates that there is a call for domestic hot water.

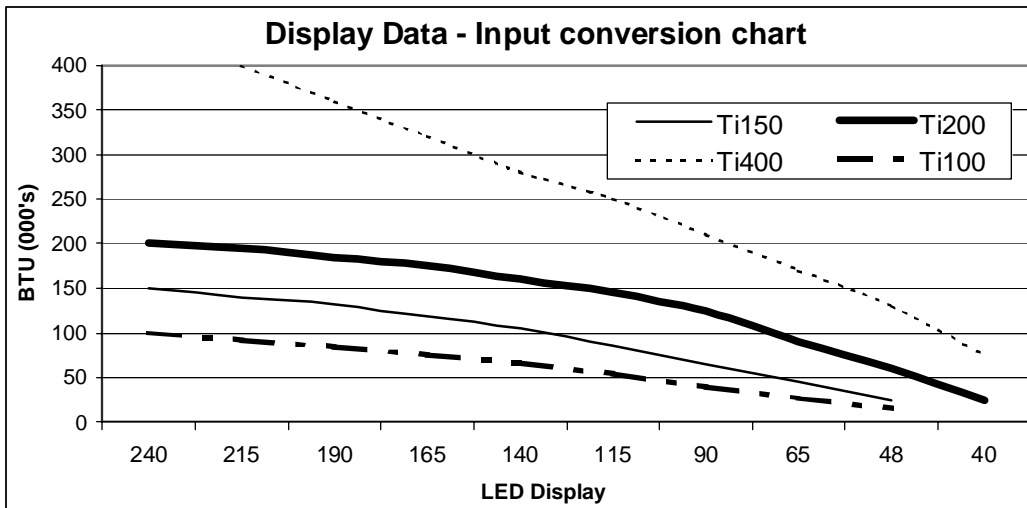

## 8.2 Sentry 2100 Operation

The Trinity boiler employs a pneumatic modulation system. This modulation system increases or decreases the velocity of the blower, to meet the demand for heating. The gas valve, senses this change, in blower pressure, and introduces the required amount of gas, to ensure correct combustion. The term “Set Point” is used to indicate the desired temperature that the Trinity will try and maintain, by increasing or decreasing the input.

Conventional Mode	T-C & A-C Open (No Storage)	T-C Closed & A-C open	T-C Closed & A-C Close	T-C Open & A-C Closed	T-C & A-C Open (Storage) <sup>Note 3</sup>
	Standby	Heating Only	Domestic Only	Domestic Only	Storage Mode
Condition	Standby	Heating Only	Domestic Only	Domestic Only	Storage Mode
Set Point	-	HI	L0	L0	160°F
Burner On	-	HI – DIF	(LO-10) <sup>Note 4</sup>	(LO-10) <sup>Note 4</sup>	140°F
Burner Off	-	HI + 10	200°F	200°F	180°F
Heat Circ. (C1)	Off	On	Off <sup>Note 1</sup>	Off <sup>Note 1</sup>	On
Aux. Circ. (Ap)	Off	Off	On <sup>Note 2</sup>	On <sup>Note 2</sup>	On

Reset Mode	T-C & A-C Open	T-C Closed & A-C open	T-C Closed & A-C Close	T-C Open & A-C Closed	T-C & A-C Open (Storage) <sup>Note 3</sup>
	Standby <sup>Note 3</sup>	Heating Only	Domestic Only	Domestic Only	Storage Mode
Condition	Standby <sup>Note 3</sup>	Heating Only	Domestic Only	Domestic Only	Storage Mode
Set Point	-	HI <sub>Calc.</sub>	L0	L0	160°F
Burner On	-	HI <sub>Calc.</sub> – DIF	(LO-10) <sup>Note 4</sup>	(LO-10) <sup>Note 4</sup>	140°F
Burner Off	-	HI <sub>Calc.</sub> + 10	200°F	200°F	180°F
Heat Circ. (C1)	Off	On	Off <sup>Note 1</sup>	Off <sup>Note 1</sup>	On
Aux. Circ. (Ap)	Off	Off	On <sup>Note 2</sup>	On <sup>Note 2</sup>	On

### Note:

- 1- For Combi units the Heating Circ. (C1) is powered for both heating and domestic hot water.
- 2- For Combi units the Aux Circ. (Ap) powers the 3-way diverter valve. (Located in the boiler)
- 3- Combi units only, unit cycles on temperature (140-180°F) for 1 to 24 hours (StO setting) after last domestic hot water call, unless StO is set to OFF.
- 4- For Combi units the burner turns on when the water temperature is less then 190°F on the initial call, afterwards it turns back on when water temperature is less then LO set point.

## 8.3 Setting the Sentry 2100

Programming is accomplished by a series of three push buttons located on the bottom side of the control. (*Function*,  $\uparrow$  and  $\downarrow$ ). To enter the programming mode, press the function key once. To scroll through the various menu options depress  $\uparrow$  until the menu is displayed. To alter the value press *Function* once, and the current value will be displayed, then use  $\uparrow$  for up, and  $\downarrow$  for down, until the desired value is obtained. To enter the selected value press *Function*, which will return to the menu. When all desired values are selected, scroll to the RUN menu, and press *Function*, which exits the Programming Mode and initiates normal operation.

### 8.3.1 Sentry 2100 Menu

Menu Item	Settable Range	Description	Typical Settings
RUN		<b>Program Mode</b> - When Run is displayed, controller is in 'Prog' mode. Arrow up or down to scroll through menu items.	NA
LO	80-190°F	<b>DHW Set Point</b> – Boiler temperature the control attempts to maintain during a domestic hot water call (A-C circuit closed).	160°F
HI	80-200°F	<b>Central Heating Set Point</b> – Boiler temperature the control attempts to maintain during a heating call (T-C circuit closed). Note: the domestic call takes priority over the heating call.	140-160°F (Fan Coil) 170-190°F (Baseboard) 100-120°F (Low temperature Infloor)
DIF	1-40	<b>Differential Setting</b> - Applies only to a heating call. Temperature difference below set point at which burner will re-light.	20
RES	70-HI	<b>Sets Outdoor Reset Curve Slope</b> – The temperature where the boiler water set-point (heat call only) equals the outdoor temperature. I.e., if RES is set to 70, then the heating set point becomes 70 when it is 70°F outdoors or higher. (Only used if outdoor sensor is connected)	85
SFS	75-100	<b>Starting Gas Input Value</b> – Settable from 45-90 on Ti400 models.	80 for Ti100-200 50 for Ti400
HFS	100-240	<b>Maximum Gas Input Value</b> – Settable from 90-195 on Ti400 models.	240 for Ti100-200 195 for Ti400
LFS	40-100	<b>Minimum Gas Input Value</b> – Settable from 35-90 on Ti400 models	50 for Ti100-150 40 for Ti200 35 for Ti400
ER5	ON/OFF	<b>DHW Time-Out</b> – When turned ON removes priority from DHW call after 2.5 hours; prioritizes heating call.	ON
FRE	ON/OFF	<b>Freeze Protection</b> – When turned ON the control operates the burner and the circulator once the temperature drops below 40°F. <b>WARNING</b> this is not a guarantee protection from freeze-up.	ON (if boiler controls primary circulator)
StO	OFF-24	<b>Storage Feature Timer</b> – Length of time in hours storage feature will keep boiler hot after the latest DHW call, only active on Combi boilers.	4 (turn OFF if Combi boiler utilizes a storage tank)

*To start the control operation, you must return to RUN in the menu, and press Function. Normal operation will begin. (\*Note: LFS must not be set below 46 on Ti100-150's.)*

### 8.3.2 Calculating Outdoor Reset Curve (RES)

#### Formula:

$$\text{Operating Temperature (HI}_{\text{CALC.}}) = \{(\text{RES} - \text{Outdoor Temp}) \times (\text{HI} - \text{RES}) / \text{RES}\} + \text{RES}$$

#### Example:

- There is a call for heat and no call for domestic hot water (T-C closed & A-C open), the control uses the programmed HI and RES settings and the current outdoor temperature.
- The HI is programmed to be 160°F.
- The RES is programmed to be 85°F.
- The outdoor temperature is 40°F.

$$\text{Operating Temperature} = \{(85 - 40) \times (160 - 85) / 85\} + 85 = \underline{125^\circ\text{F}}$$

The following chart illustrates the effect of changing outdoor temperature on the boiler operating temperature for the above example.

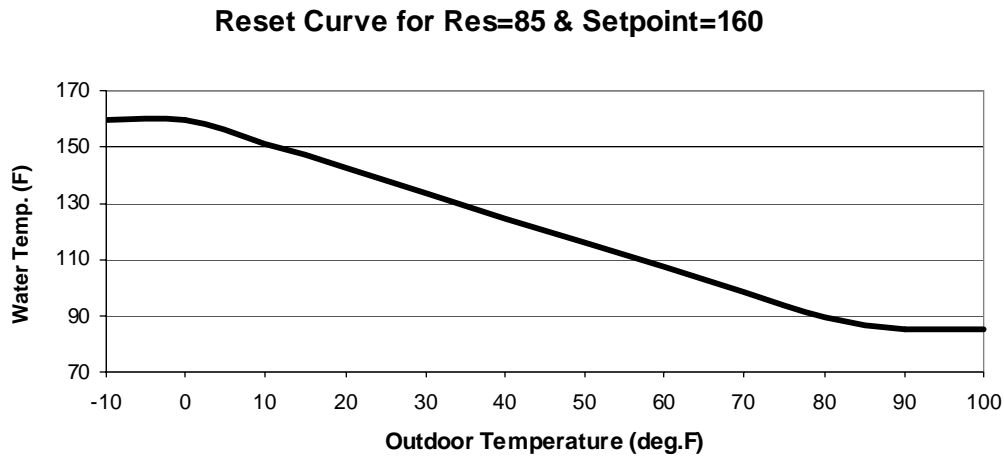

### 8.4 Outdoor Sensor (10K)

To fully take advantage of the energy saving features of the Trinity boiler, it is necessary to install the outdoor sensor provided. Install the sensor preferably on the north, or coldest side of the building, not within 10 feet of the discharge of the gas vent outlet, or other sources of heat. The outdoor sensor connects to the top of the boiler on terminals O and D (terminals are located at the top of the left side panel on Ti400 models).

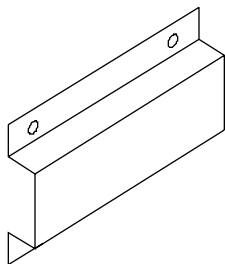

Sensor # 81027-1

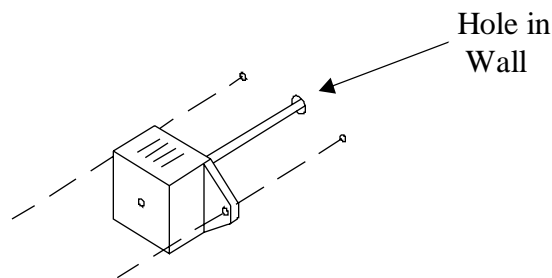

Sensor # 83460 (replaces 81027-1)

## 9.0 LIGHTING BOILER

### 9.1 Initial Start-up

- **Ensure that the boiler is wired in accordance with this manual.**
- **Ensure that the gas shut-off valve is turned on, and that the gas system has been fully tested for leaks.**
- **Ensure that the system is completely filled with water, and that ALL the air is purged out.**
  1. Turn on power to the Trinity Boiler. The boiler should run through a purge, and combustion should occur. (The control system has a built in ignition retry, allowing the system to retry at least four times, before locking-out.)
  2. Verify that the gas line pressure is 4-9"wc. for natural gas, and 9-12" wc. for propane.
  3. Using an appropriate Oxygen or Carbon Dioxide analyzer, take a sample of the flue gas. The sample must fall within the acceptable ranges for carbon Dioxide, which is 8% - 9.5% for natural gas, and 9.0%-10.5% for propane. **If the reading does not fall within this range, contact NY Thermal, for assistance.**
  4. Perform at least three lights in succession to ensure proper operation.
  5. After the three successive lights, unplug the flame probe, and allow the unit to cycle again. Ensure that it tries to light, and locks out on safety reset. Once you have successfully activated the flame safety system, replace the wire on the flame sensor, and reconfirm proper lighting.

#### For Your Safety, Read before operating

- A. This appliance does not have a pilot. It is equipped with an ignition device that automatically lights the burner. Do not try to light the burner by hand.
- B. BEFORE OPERATING, check all around the appliance area for gas. Be sure to check next to the floor, as some gases are heavier than air, and will settle on the floor.
- C. Use only your hand to turn gas knobs, never use a tool. Forcing the valve, or attempting to repair it can cause fire or explosion.
- D. Do not use the appliance if any part is under water.

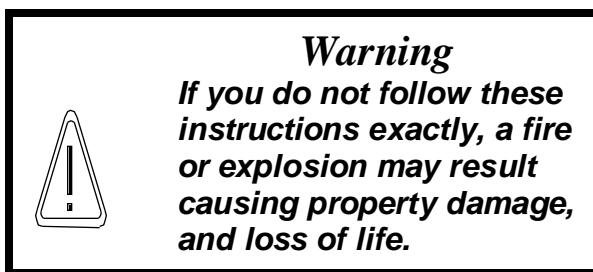

### 9.2 Re-lighting Unit

1. Stop and read these instructions very carefully.
2. Set the thermostat to the lowest setting, and then turn off all power to the boiler.
3. This appliance does not have a pilot. It is equipped with an ignition device that automatically lights the burner. Do not try to light the burner by hand.
4. Turn the gas shut-off valve to the off position, and then remove the front cover.
5. Wait five (5) minutes to clear out any gas. Then check for gas, including near the floor. If you smell gas "Stop" and follow "B" above. If you don't detect any gas proceed to the next step.
6. Turn the gas shut-off valve to the on position, wait an addition five (5) minutes and check for gas.
7. Replace the front cover.
8. Set the thermostat to the highest setting, and then turn on all power to the boiler.
9. Ignition sequence is automatic, combustion will occur after a brief fan purge. Ignition will retry 3 times.
10. If ignition does not occur, "Turn off the gas and electricity to the boiler" and contact a professional service technician, or gas supplier.

### 9.3 Turn off Boiler

1. Set the thermostat to the lowest setting, and then turn off all power to the boiler.
2. Turn the gas shut-off valve to the off position.

## 10.0 TROUBLE SHOOTING

This section is intended to assist the service technician in detecting and correcting common errors. The Sentry 2100 is equipped with an internal diagnostic system that verifies control operation. The following series of error codes has been developed to aid in diagnosing control problems:

<b>Problem</b>	<b>Detected Problem</b>	<b>Solution</b>
<b>ER1</b> On Display	<b>“Water Temperature Excessive”</b> Sentry has sensed a water temperature in excess of 250°F at the Water Sensor.	1 – If the boiler is extremely hot check for adequate water pressure and circulation, contact NTI for assistance. 2 – If not hot, check for sources of grounding or shorting at the Water Sensor electrical connections, check wiring from Sensor to Sentry Control. 3 – Replace Water Sensor if the resistance is not in the correct range. (See resistance charts for 1 Mohm Trinity Thermister)
<b>ER2</b> On Display	<b>“Water Sensor Short Circuit”</b> Sentry has sensed a short circuit in the Water Sensor circuit.	See ER1.
<b>ER3</b> On Display	<b>“Water Sensor Open Circuit”</b> Sentry has sensed an open circuit in the Water Sensor circuit.	1 – Check wiring to Water Sensor for open circuits or shorting to ground. (Note: ER3 will be displayed if temperature sensed is less than 0°F.) 2 – Replace Water Sensor if the resistance is not in the correct range. (See resistance charts for 1 Mohm Trinity Thermister)
<b>ER4</b> On Display	<b>“24V Limit Error”</b> Sentry has sensed a lack of 24V on the outlet of the Sentry burner relay (B1).	The error locks the boiler out for one hour before retrying ignition. 1 – Reset power, if error goes away the problem is intermittent and was likely caused by a tripped limit that has automatically reset, check for adequate water pressure and flow rate. Allow the boiler to cycle and verify proper operation including outlet water temperature and flue temperature. If operation is unsuccessful and the error reoccurs: 2 – Ti100-200’s are equipped with a low water pressure switch on the boiler return that requires a minimum of 10PSI to complete the 24VAC ignition circuit. Ensure there is a minimum of 12PSI on the boiler outlet, prior to the primary circulator; ensure the boiler is plumbed in primary-secondary fashion. Replace water pressure switch if plumbing and pressure is correct and if it measures an open circuit. 3 – Ti400’s are equipped with a flow switch on the boiler outlet. Ensure the flow switch is closing, if not check for proper flow rate. 4 – Check for continuity through the 24VAC limit wiring and manifold and stack limits, replace limits or wiring that are not a closed circuit.
<b>ER5</b> On Display	<b>“DHW Time-Out”</b> The ER5 option is ON and the Sentry has sensed that the DHW call has lasted longer than 2.5 hours, thus removing priority from the DHW call.	Reset the ER5 error by resetting the power or cycling the DHW call. Check for proper operation of the DHW call. 1 – Combi’s are equipped with a DHW flow switch; ensure it is not sticking in the closed position when there is no DHW flow. If so, remove it and free it of any debris and check for proper operation, replace if necessary. 2 – For non-Combi boilers, operating with an indirect water heater, check for proper boiler water circulation during a DHW call, and check for proper operation of the indirect water heater’s Aquastat. 3 – For applications with prolonged DHW draws, turn the ER5 option OFF.
<b>ER6</b>	<b>“Flame Lock Out”</b> Sentry has sensed a lack of 24V to the gas valve during operation or a Fenwal ignition lockout.	1- There is a problem in the ignition sequence, it could be caused by a faulty igniter, flame sensor, gas valve or improper line pressure or combustion. Check ignition sequence to determine which component is not functioning. ( <i>Sentry will retry ignition sequence 1 hour after ER6 code originally occurs or if control is reset</i> )
<b>Burner shuts off before set-point temperature is reached</b> (and burner light goes out)	Reset calculation being used to lower HI setting.	If OD probe is being used, the HI setting will be calculated using formula in Section 8, adjust RES setting as necessary.
	Thermostat is satisfied	1-If the thermostat demand light is turning off, the thermostat has satisfied. 2-If DHW temp light is turning off; the aquastat or call for domestic has been satisfied.
<b>ER9</b>	<b>Internal Controller Fault</b>	Indicates that the Sentry control has lost communication with an internal processor, contact NTI for assistance.

<p><b>ASO</b> Indicates that the Air Switch is Open</p>	<p><b>“Air Switch Open”</b></p> <p>This is displayed when the boiler is expecting the air switch to be closed by a differential pressure generated when the combustion blower turns on.</p>	<p>1 – Are the vinyl tubes connected between the air switch and the ports on the inlet pipe? Negative side of switch connects to the port on the 1-1/2” PVC elbow (2” elbow on Ti400).  2 – Check for blockage on the intake and exhaust vents.  3 – If fan is running the air switch may be faulty, ensure it is set at 0.2”wc. (Note: switch on Ti400 condensate drain must be set at 3”wc.)  4 – If fan is not running, check 120V wiring to blower, if ok remove low voltage harness from blower, if blower fails to start, replace blower, if blower does start problem may be with blower or Sentry control.</p>
<p><b>ASC</b> Indicates that the Air Switch is Closed</p>	<p><b>“Air Switch Closed”</b></p> <p>This is displayed when the boiler has turned the blower off and is expecting the air switch to be open.</p>	<p>1 – Is the fan running. If so check for 24V between B and D terminals (see wiring diagram). If 24V is not present replace transformer.  2 – Check venting termination with required venting described in manual.</p>
<p><b>Two Flashes on Fenwal</b></p>	<p><b>“Flame Fault”</b></p> <p>The Fenwal controller senses flame prior to ignition sequence.</p>	<p>If the combustion sequence is normal, and there is no flame prior to ignition, the Fenwal control is defective, and must be replaced.</p>
<p><b>Three Flashes on Fenwal</b></p>	<p><b>“Ignition Lockout”</b></p>	<p>If the condensate drain gets blocked, the boiler will become flooded and terminate operation as the flame rod becomes immersed. This will damage the flame probe. To correct, free the drain blockage, and permanently prevent it from reoccurring. Remove and dry off the probe. Reinstall the probe and try for ignition, if it fails to stay lit, leave the fan run for up to three hours to dry out the insulation and probe.</p> <p>Reset Boiler so it will attempt to ignite.  Check for proper operation of ignition components. Make sure igniter glows and gas valve opens.  Check for proper line pressure at gas valve when it opens.  If boiler lights check for flame signal between FC1 And FC2 on Fenwal control (If lower than 1.2 DC <math>\mu</math>Amps see <b>“Boiler will not stay lit”</b>).  Check combustion properties.</p>
<p><b>Boiler will not stay lit.</b></p>	<p>Indicates lack of a flame signal. In order to stay running the flame signal must be at least 0.7 <math>\mu</math>Amps</p>	<p>If the Burner light on the Sentry is going out, go to <b>“Burner shutting off”</b>.  Check condensate drain for blockage and check the inlet piping for ingested snow or water (if the flame rod gets wet, it may need to be replaced). Check for resistance from flame rod to ground, must be an open circuit (O.L), if not, remove rod and bent it away from the burner slightly.  Check for proper polarity of line and neutral wiring to the boiler.</p>
<p><b>Boiler bangs or hisses</b></p>	<p>Bangs or sounds like a kettle while burner is running indicates insufficient flow</p>	<p>1 - Ensure the plumbing is as shown in manual. Check to see if pumps are operating properly and water pressure is above 15psi. <b>This problem can lead to boiler overheating!</b>  2 - Boiler may be plugging-up with scale or magnetite, clean with Fernox DS-40 Descaler and Cleanser (NTI PN: 83450).  3 - If glycol is being used the concentration may be to high, recommend using a concentration lower than 35%.</p>
<p><b>Sentry Controller Locks-up</b></p>	<p>Excessive noise, current, or voltage spikes in the 120V power supply.</p>	<p>Check for voltage at the wires going to the A-C-T-O-D terminals of the Boiler.  Check the magnitude of the line voltage power supply.  Check the Amp draw of output C1 and Ap (max 3 Amp).  Check the Amp draw of control on start-up (max 6 Amps)</p>
<p><b>Display Goes Blank</b></p>	<p>No power to control or control failure</p>	<p>Check for 120V between terminals L1 and L2 at Sentry.  If 120V exists turn power off and remove line voltage harness from Sentry. Then check for resistance between L1 and L2 of control, if the circuit is open (O.L) the internal fuse has blown. Check for shorts in wires leading to circulators prior to replacing controller.  If 120V not present, check wiring and for 120V at source.</p>
<p><b>Boiler Lights rough or pulsates</b></p>	<p>Typically an imbalance in the Air to gas ratio</p>	<p>Ensure that the venting lengths are in compliance with Section 3.4  Ensure that the line pressure during operation does not drop more than 20% from the static line pressure.  Momentarily remove the intake vent from the boiler during ignition, if unit lights smoothly with intake vent disconnected reconnect and check for proper combustion if unit maintains smooth operation after ignition. (See Section 5.2) Calibrate for proper combustion. If problem persists contact NY Thermal.  Heat exchanger may be dirty, remove burner door and inspect, clean if necessary.</p>

<b>Fan appears to be creating a noise in the house</b>	Slight vibration can cause noise in the residence (This is not a warranty issue)	Use flexible gas line to insolate the vibration noises between the gas valve and the line. Don't hang gas lines from floor joists. Use rubber insulators with gas line supports.
	Making a rubbing noise. ((This is not a warranty issue))	If gas valve is not held when the gas nipple is connected, the force of tightening the fitting can damage the valve, and warp the fan housing. If pipe is used, the gas line must not create any forces to the valve, either vertically (weight of line), or horizontally (misaligned connection)

The following are the thermister curves for diagnosing the water and outdoor air sensors.

1. Measure the resistance of the thermister when disconnected.
2. Using the appropriate chart, find the resistance and move either vertical (Water Sensor) or horizontal (air probe) until the line is intersected.
3. Move 90 degrees to the corresponding temperature.
4. If the temperature is plus or minus 10 degrees, then the probe is operating correctly.

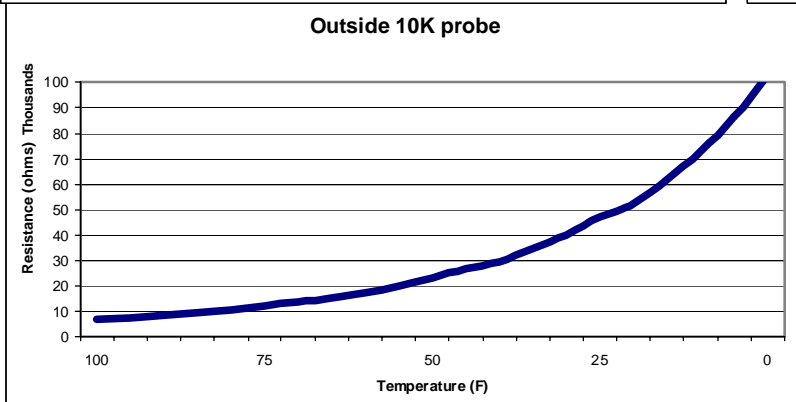
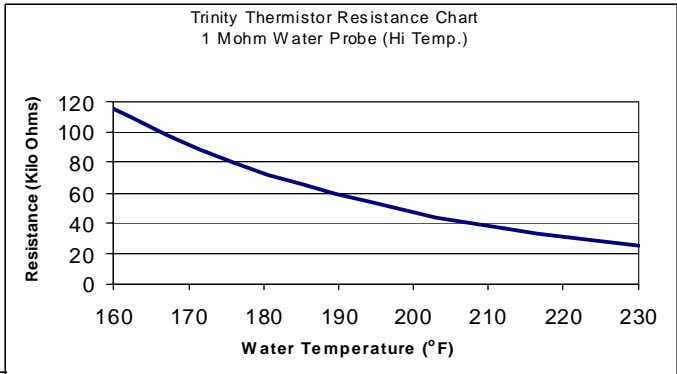
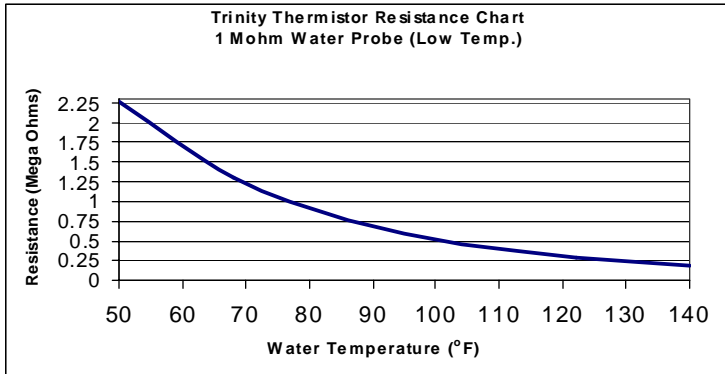

# 11.0 SEQUENCE OF OPERATION

The following is the normal sequence of operation for the trinity boiler.

## Trinity Sequence of operation

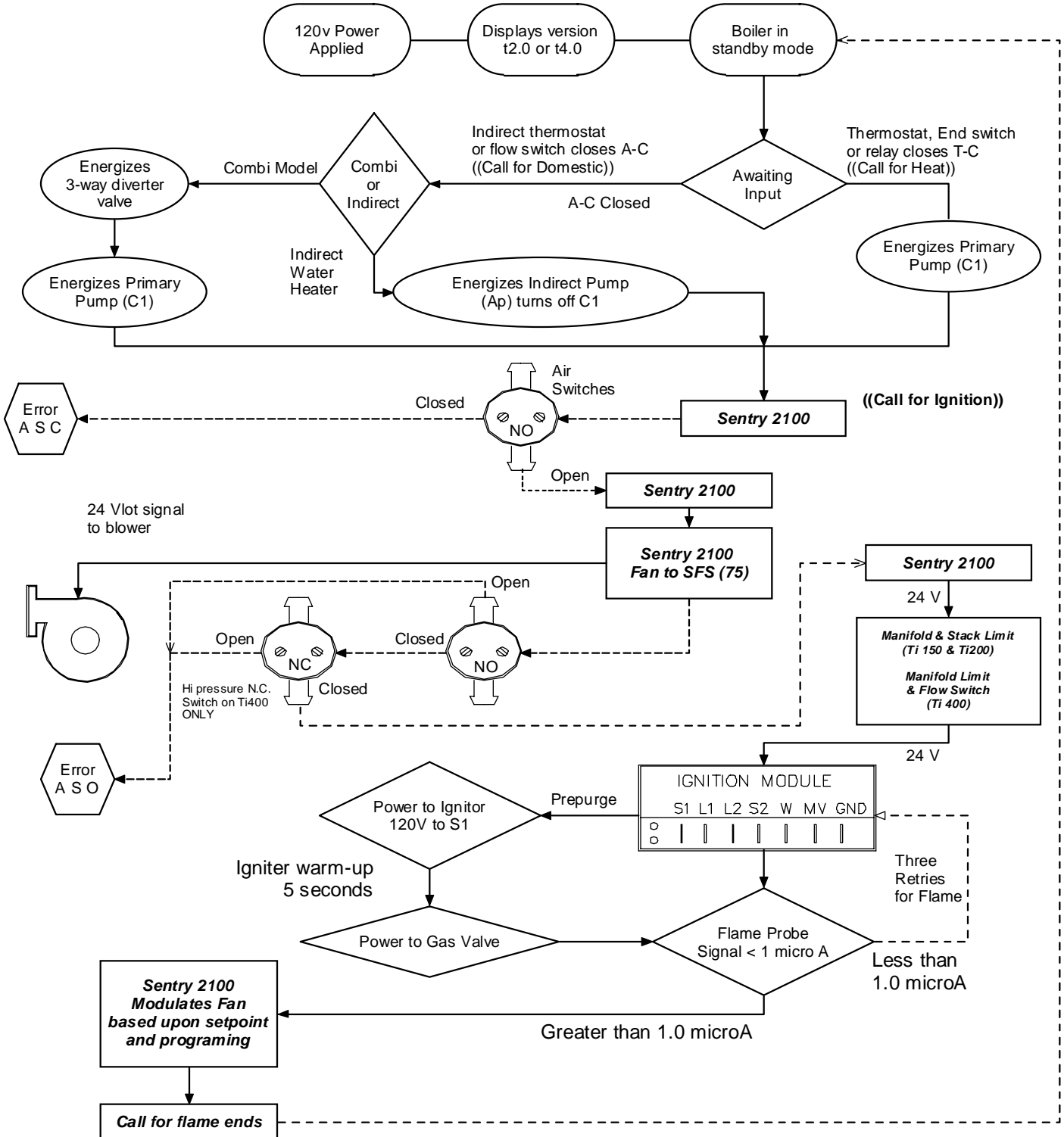

# 12.0 WIRING SCHEMATIC

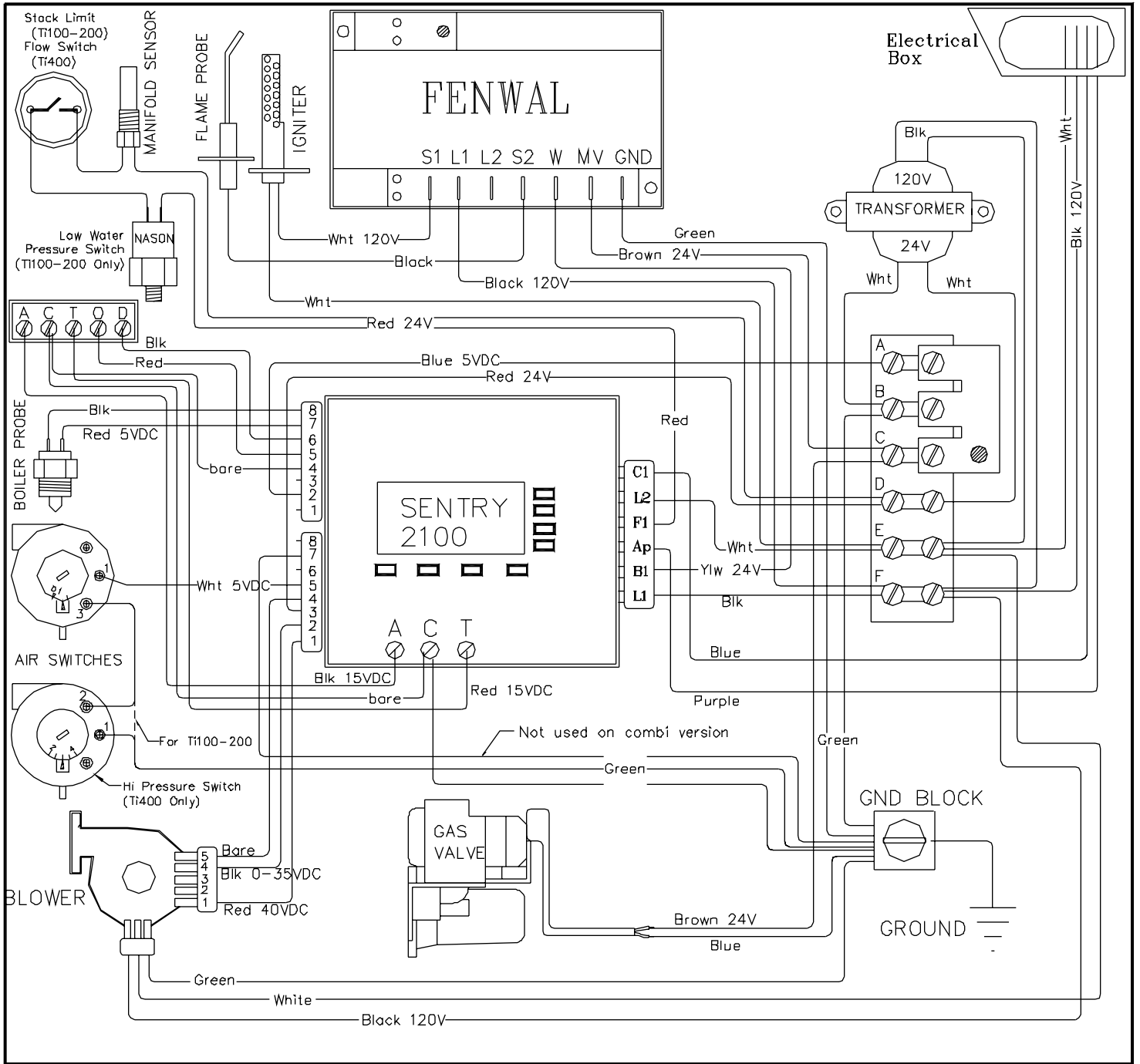

## 13.0 INSTALLATION CHECKLIST

### Installation

- a) Connect all plumbing, and ensure that there are no system leaks, add Fernox F1 Protector (NTI PN: 83448).
- b) Connect, secure, and glue all vent piping.
- c) Install all gas piping as per this manual, and local codes. Pressure test, to detect any gas leaks.

### Start-up

1. Install pressure gauge (Gauge= 0" to 15" w.c. scale) and check line and manifold pressures. (See "Section 5.2")
2. Turn gas shut-off valve to the ON position.
3. Turn Power on to boiler.
4. Set Sentry Controller to desired settings.
5. Turn thermostat up, Ignition will occur.

### Operational Checklist

Ensure that Carbon Dioxide Readings are within the acceptable ranges. Using an appropriate Oxygen or Carbon Dioxide analyzer, take a sample of the flue gas. The sample must fall within the acceptable Carbon Dioxide ranges, which is 8% - 9.5% for natural, and 9.0% - 10.5% for propane. (See "Section 5.2")

### Before Leaving

- Remove gauge from gas valve and tighten bleed screw and test plug for leaks.
- Allow boiler to complete at least one complete cycle, or at least 15 minutes running time.
- **Always verify proper operation after servicing**

## 14.0 ANNUAL MAINTENANCE AND INSPECTION

This unit requires very little maintenance, however a

Qualified Technician should inspect it at the beginning of every heating season. **Inspection Check list:**

- 1.) Lighting is smooth and consistent, and the combustion fan is noise & vibration free.
- 2.) The condensate freely flows from the unit, and is cleaned of sediment.
- 3.) Relief Valve and air vents are not weeping.
- 4.) Low water cut off is flushed (if applicable)
- 5.) Examine all venting, for evidence of leaks, and vent screens are cleaned.
- 6.) Check the burner plate for signs of leaking.
- 7.) Verify the vent clearance as per Section 3.0
- 8.) Listen for water flow noises indicating a drop in boiler water flow rate. The boiler and hydronic system may need to be flushed to eliminate hard water scale (Use Fernox DS-40 Descaler – NTI PN: 83450).

### 14.1 Combustion Chamber Cleaning

**Once every second year** the burner door should be removed so the combustion chamber can be inspected for flue gas blockage. Such blockage will reduce the boiler's capacity/firing rate and can impact negatively on how smooth and efficiently the burner lights. Vacuum out any loose build-up and clean the heat exchanger surface with an appropriate cleaner for combustion chambers. Use nylon or other non-metallic brush to loosen the sulfate incrustations and any other contaminants. Rinse with water allowing the solution to exit via the condensate drain. This process may warrant removing the insulation disc from the back of the heat exchanger.

### **IMPORTANT**

***It is imperative that you explain to the homeowner that it is their responsibility to:***

- ***Keep the vent terminal free of snow and ice.***
- ***Periodically check the vent terminal for debris.***

## 15.0 PARTS LIST

### Models Ti100-Ti200

Replacement parts are available from your stocking wholesaler. Homeowners must contact their local Installer or Wholesaler. Installers or Wholesalers may contact NY Thermal Inc. for assistance at 506-432-1130. Notes: \*Used for Combi version only.

No.	P.N.	Description
1	82657	Premix burner, 135.8 Ti-150
1	82658	Premix burner, 200.6 Ti-200
1A	82761	Premix Burner Gasket
2	82457	Transformer, 24V
3	82013	Sentry 2100
4	82052	Blower #RG130 Ti-150 Only
4	82661	Blower #RG148 Ti-200 Only
5	82054	Gas Valve (CVI) VK8115F1134B
5A	82065	Gas Valve 1/2" npt elbow
5B	82600	Gas Valve Vent connection
6	82662	Air switch Huba @ .2"wc.
7	82671	Thermister (Ti100-200)
7	83035	Thermister (Ti100-150 ASME)
8	82058	Ignition Module (Fenwal)
9	82708	IGNITER, #601, c/w SS shield
10	82762	Rauschert Flame Rod
11	82763	Composit Flue Box
11A	82764	Composit Flue Box Gasket
11B	82765	Composit Flue Outlet Gasket
11C	83291-1	Flue Adapter Assembly (Ti100-200)
12	82659	Manifold Limit, 1/8BSP(Ti100-200)
12	82992	Manifold Limit, 1/4NPT(Ti100-150 ASME)
13	82596	Ti100-150 Heat Exchanger
13	83012	Ti100-150 ASME Heat Exchanger
13	82647	Ti 200 Heat Exchanger
14	82650	LP orifice 5.20mm Ti150-200 Only
14	83216	LP orifice 3.40mm Ti100 Only
15	82660	Stack Limit, 1/4BSP,190F, Dif=30
16	82766	Blower gasket Ti100-150 Only
16	82719	Blower gasket Ti200 Only
17	82622-1	Ti Inlet Pipe assembly
18	83042	Condensate Y Drain
18A	82913	Siphon Condensate Trap
19	82767	Cast aluminum Burner door
19A	82769	Ti Ceramic burner door disc
19B	82770	Ti Burner door gasket
20	82768	Ti Igniter gasket
21	82228*	Tempering valve #AM101-US-1
22	82771	Extended air tube
23	82011*	Plate heat exchanger LA1430
24	81896*	Flow switch FS-380, .5activate
25	82160*	3 way Valve VU54S2016B, 3/4"
26	82159*	3 way actuator VU444A1007B
27	82754	Control panel & Harness
27A	82754-1	PCB Optocoupler
28	82054-1	CVI Venturi 01 (Ti150 & 200)
28	83205	CVI Venturi 003 (Ti100 Only)
28A	82054-2	CVI Venturi Gasket
29	82104-1	Ti Air metering Elbow
30	81027-1	Sentry (10k) Outdoor Air Sensor
31	83223	Pressure Switch 1/8BSP
31	83223-1	Pressure Switch 1/4NPT (Ti100-150ASME)
32	83112	Divider plate insul (c/w washer & screw)
33	83462	Tee, Brass, 1/4"
33	83458	Tee, Brass, 1/8"
34	82539	Auto Air Vent, 1/8"
35	83059	Terminal Strip
36	82411-3	Ti100-200 Cover

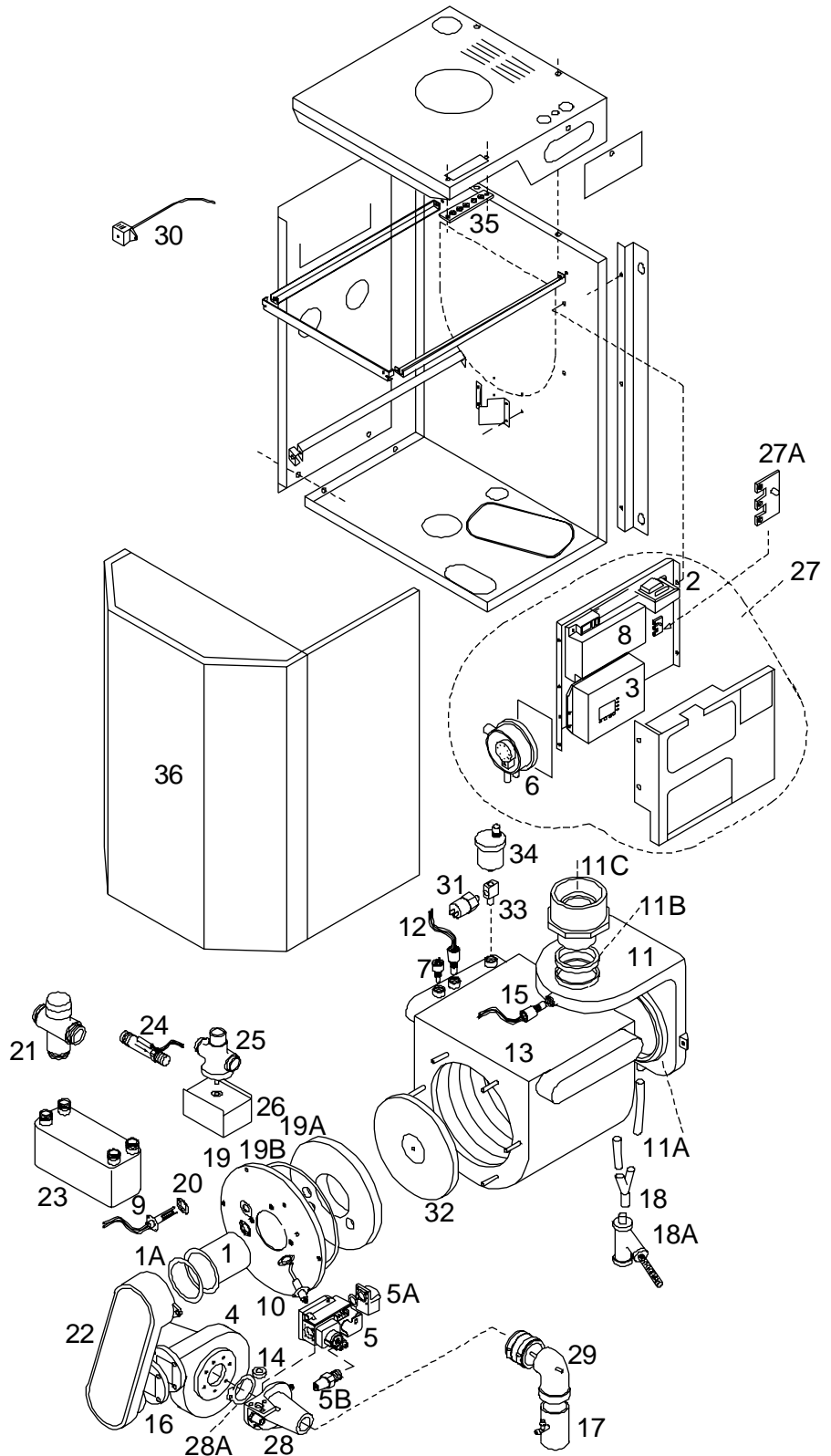

**Model Ti400**

No.	P.N.	Description
1	83173	Premix Burner NIT 327 (For Ti400)
1A	82761	Premix Burner Gasket
2	82457	Transformer, 24V
3	83171	Sentry 2100 Assembly
4	82994	EBM BLOWER #RG148/E
5	82989	Gas Valve VR8615VB 1044B
5A	82991	Gas Valve Adapter, 3/4" NPT
5B	83194	Gas Valve Connector O-ring
	83016	Gas Valve Harness
6	82662	Air switch Huba @ 0.2"wc.
6C	82539	Air Vent
7	83035	Thermister NTC 1/4" NPT, 1Mohm
8	82058	Ignition Module (Fenwal)
9	82708	IGNITER, #601, c/w SS Heat shield
10	82762	Flame Rod Rauschert (Ti-Series)
11	82906	Air Switch 604.E421180 set @ 3" wc
12	82992	Limit Switch, 1/4"NPT, (Manifold)
13	82926	Ti-400 Heat Exchanger, ASME
14	82993	Gas Valve Orifice, 8.0mm, NG
14A	83017	Gas Valve Orifice, 6.2mm, LP
15	81887	Flow Switch, FS-10C (Ti 400)
16	82766	Blower Gasket (Ti100, 150 & 400)
17	83037	Condensate Tee 3/4"HB to 3/4"
17A	83038	Adapter, 3/4" x 1/4"
18	82913	SIPHON CONDENSATE TRAP
19A	82769	Burner Door Ceramic Disc
19B	82770	Burner Door Viton Gasket
20	82768	Igniter Gasket (Ti-Series)
21	83034	Exhaust Test Plug (Ti 400)
22	83195	Extended Air Tube (Ti400)
23	83141	Ti 400 Control Panel, Complete
24	82990	CVI Venturi (Ti 400)
25	83106	O-ring, Venturi to Blower (Ti400)
26	83001	Test Port Retaining Clamp (Ti 400)
27	82754-1	PCB Optocoupler
28 29	83170-1	Air Metering Assembly (Ti 400)
30	81027-1	Sentry 2100 (10K) Outdoor Probe
31	83018	Vent Screen, 4" (Ti 400)
32	83019	Vent Screen, 6" (Ti 400)
33	83013	Nipple, 1-1/4" x 8", Brass
34	83005	1-1/4"x 1-1/4"x 3/4" Tee Brass
35	13701	RELIEF VALVE 3/4" #335 30 PSI
36	82148	PRESSURE GAUGE 0-30 PSI
37	83112	Divider Insul. (c/w washer & screw)
38	83059	Terminal Strip
39	82411-1	Ti400 Front Cover

