

Operating Instructions & User's Information Manual

VIESSMANN[®]

Vitodens 100-W

WB1B Series

Wall-Mounted, gas-fired condensing boiler
with optional on demand hot water Combi**PLUS** Kit

Heating input: 37 to 118 MBH
10.8 to 34.5 kW



VITODENS[®] 100-W

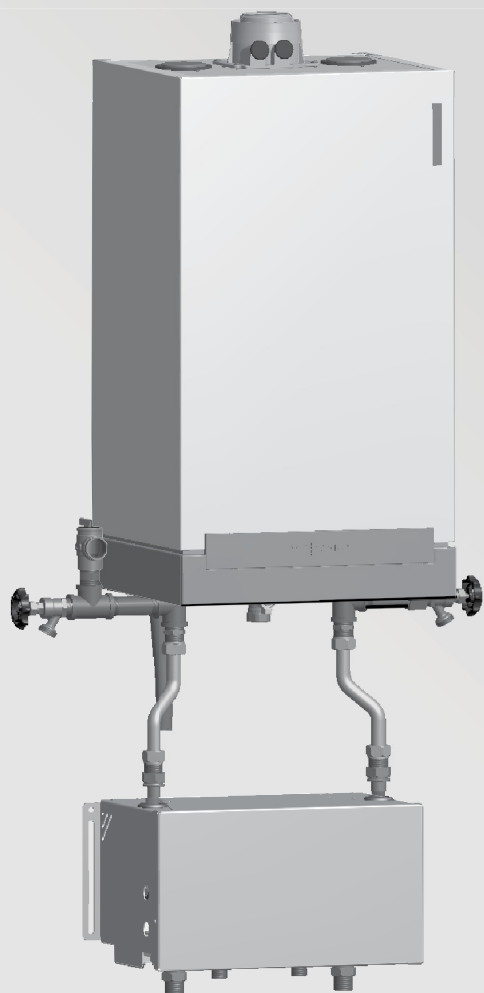

WARNING

If the information in this manual is not followed exactly, a fire or explosion may result causing property damage, personal injury or loss of life.

Do not store or use gasoline or other flammable liquids in the vicinity of this or any other appliance.

WHAT TO DO IF YOU SMELL GAS

- Do not try to light any appliances.
- Do not touch any electrical switches, do not use any phone in your building.
- Immediately call your gas supplier from a neighbor's phone. Follow the gas supplier's instructions.
- If you cannot reach your gas supplier, call the fire department.

Installation and service must be performed by a qualified installer, service agency or the gas supplier.

WARNING

Improper installation, adjustment, and/or operation could cause carbon monoxide poisoning resulting in injury or loss of life.

This product must be installed and serviced by a professional service technician who is experienced and qualified in hot water boiler installation and gas combustion.

IMPORTANT

Read and save these instructions for future reference.



Safety, Installation and Warranty Requirements

Please ensure that these instructions are read and understood before commencing installation. Failure to comply with the instructions listed below and details printed in this manual can cause product/property damage, severe personal injury, and/or loss of life. Ensure all requirements below are understood and fulfilled (including detailed information found in manual subsections).

■ Product documentation

Read all applicable documentation before commencing installation. Store documentation near boiler in a readily accessible location for reference in the future by service personnel.

► *For a listing of applicable literature, please see section entitled "Important Regulatory and Safety Requirements".*



■ Warranty

Information contained in this and related product documentation must be read and followed. Failure to do so renders the warranty null and void.



■ Licensed professional heating contractor

The installation, adjustment, service and maintenance of this equipment must be performed by a licensed professional heating contractor.

► *Please see section entitled "Important Regulatory and Installation Requirements".*



■ Contaminated air

Air contaminated by chemicals can cause by-products in the combustion process, which are poisonous to inhabitants and destructive to Viessmann equipment.

► *For a listing of chemicals which cannot be stored in or near the boiler room, please see subsection entitled "Combustion Air Supply".*



■ Carbon monoxide

Improper installation, adjustment, service and/or maintenance can cause flue products to flow into living space. Flue products contain poisonous carbon monoxide gas.

► *For information pertaining to the proper installation, adjustment, service and maintenance of this equipment to avoid formation of carbon monoxide, please see instructions supplied with burner.*



■ Fresh air

This equipment requires fresh air for safe operation and must be installed ensuring provisions for adequate combustion and ventilation air exist.

► *For information pertaining to the fresh air requirements of this product, please see subsection entitled "Combustion Air Supply".*

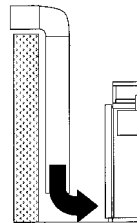

■ Equipment venting

Never operate boiler without an installed venting system. An improper venting system can cause carbon monoxide poisoning.

► *For information pertaining to venting and chimney requirements, please see section entitled "Venting Connection". All products of combustion must be safely vented to the outdoors.*



■ Advice to owner

Once the installation work is complete, the heating contractor must familiarize the system operator/ultimate owner with all equipment, as well as safety precautions/requirements, shutdown procedure, and the need for professional service annually before the heating season begins.



WARNING

Installers must follow local regulations with respect to installation of carbon monoxide detectors. Follow manufacturer's maintenance schedule of the boiler contained in "Service Instructions" manual.

	Page
General Information	
	About these Instructions..... 4
Safety	
	For your Safety..... 4
	Operation..... 4
	Flue gas smell..... 4
	Working on the equipment..... 4
	Dangerous conditions..... 4
	Maintenance and cleaning..... 4
	Technical Information..... 4
	Carbon monoxide..... 5
	For safe operation..... 5
	Frozen water pipe hazard..... 6
	Installation area conditions..... 7
Start-up	
	Overview of Controls and Indicators..... 8
	Control and display elements..... 8
	Your Vitodens 100 Boiler..... 9
Operation	
	Changing Room Temperature..... 9
	Heating System Operation..... 10
	Switching ON..... 10
	Switching OFF..... 10
	Domestic Hot Water..... 11
	With CombiPLUS kit only..... 11
	Comfort Function..... 12
	Starting the comfort function..... 12
	Stopping the comfort function..... 12
	Heating Water Temperature and System Pressure..... 12
	Switching OFF Vitodens with Frost Protection..... 13
	Shutting Down the Heating System..... 13
	Fault Diagnosis and Correction..... 14
	Fault Messages on the Display..... 15
	Service Instructions for your Heating System..... 15
Information	
	How to Save Energy..... 16
	Lighting and Operating Instructions..... 17

About these Instructions



Take note of all symbols and notations intended to draw attention to potential hazards or important product information. These include "WARNING", "CAUTION", and "IMPORTANT". See below.

WARNING

Indicates an imminently hazardous situation which, if not avoided, could result in death, serious injury or substantial product/property damage.

► *Warnings draw your attention to the presence of potential hazards or important product information.*

CAUTION

Indicates an imminently hazardous situation which, if not avoided, may result in minor injury or product/property damage.

► *Cautions draw your attention to the presence of potential hazards or important product information.*

IMPORTANT

► *Helpful hints for installation, operation or maintenance which pertain to the product.*



► *This symbol indicates that additional, pertinent information is to be found.*



► *This symbol indicates that other instructions must be referenced.*

For your Safety

■ Operation

Before operating the boiler, make sure you fully understand its method of operation. Your heating contractor should always perform the initial start-up and explain the system. Any warranty is null and void if these instructions are not followed.

■ Flue gas smell

- Deactivate heating equipment.
- Open windows and doors.
- Inform your heating contractor immediately.

■ Working on the equipment

All personnel working on the equipment or the heating system must have the **proper qualifications** and hold all necessary licenses.

Ensure **main power** to equipment, heating system, and all external controls have been **deactivated**. **Close main gas supply valve**. Take precautions in all instances to avoid accidental activation of power during service work.

■ Dangerous conditions

- Deactivate main power immediately.
- Close gas supply valve.

■ Maintenance and cleaning

Regular inspection and service by a qualified heating contractor is important to the performance of the Viessmann Vitodens 100-W. Neglected maintenance impacts on warranty; regular inspection ensures clean, environmentally friendly and efficient operation. We recommend a maintenance contract with a qualified heating contractor.

■ Technical information

- Technical Data Manual
- Installation and Service Instructions
- Operating Instructions and User's Information Manual
- Vitodens Venting System Installation Instructions
- Quick Start-up Guide
- Instructions of other products utilized and installed
- Installation codes mentioned in this manual

For your Safety *(continued)*

■ **Carbon monoxide**

The U.S. Consumer Product Safety Commission strongly recommends the installation of carbon monoxide detectors in buildings in which gas-burning equipment is installed. Carbon monoxide (CO) is a colorless, odorless gas, which may be produced during incomplete combustion of fuel and/or when the flame does not receive an adequate supply of combustion air.

Carbon monoxide can cause severe personal injury or loss of life.

Therefore, carbon monoxide detectors that are in compliance with a nationally recognized standard (e.g. ANSI/UL 2034-2002, CSA 6.19-01) should be installed and maintained in buildings that contain gas-burning equipment.

Note: Viessmann does not test any detectors and makes no representation regarding any brand or type of detector.

■ **For safe operation**

We recommend that you frequently:

- Check for debris which could obstruct the flow of flue gases. The vent or chimney must not be blocked. A blocked or partially blocked vent or chimney can cause flue gases to leak into the structure. Flue gases leaking into the house can cause injury or death. A qualified heating contractor must remove the blockage from blocked or partially blocked chimneys.
- Check pressure gage for correct system (water) pressure. Check for water on the floor from the discharge pipe of the pressure relief valve or any other pipe, pipe joint, valve or air vent.
- Check for moisture, water, or appearance of rust on the flue gas pipes, their joints as well as vent dampers, or side wall vent terminals (if so equipped).
- Ensure that nothing is obstructing the flow of combustion and ventilation air and no chemicals, garbage, gasoline, combustible materials, flammable vapors and liquids are stored (not even temporarily) in the vicinity of the boiler.
- Do **not** allow unsupervised children near the boiler.

Service/inspection of the boiler and the system is recommended once per year. Maintenance, service and cleaning are specified in the Installation and Service Instructions.

Before the heating season begins, it is recommended that the boiler and burner be serviced by a qualified heating contractor. Service contracts may be established through gas suppliers or other licensed contractors in your area.

 **WARNING**

As there are no user-serviceable parts on the boiler, burner or control, the end-user must not perform service activities or adjustments of any kind on system components. Failure to heed this warning can cause property damage, severe personal injury, or loss of life.

 **WARNING**

Improper installation, adjustment, service, or maintenance can cause flue products to flow into living space. Flue products contain poisonous carbon monoxide gas which can cause nausea or asphyxiation resulting in severe personal injury or loss of life.

 **CAUTION**

Should overheating occur or the gas supply fail to shut off, do not disconnect the electrical supply to the pump. Instead, shut off the gas supply at a location external to the appliance.

 **WARNING**

The operator/ultimate owner is required to have the heating boiler, burners, and controls checked, as a minimum once per year, by the original installer or by a competent heating contractor familiar with the equipment. Defects must be corrected immediately.

 **CAUTION**

Do not use this boiler if any part has been under water. Immediately call a qualified heating contractor to inspect the boiler and to replace any part of the control system and any gas control which has been under water.

For your Safety *(continued)***Frozen water pipe hazard****WARNING**

Failure to protect against frozen pipes could result in burst water pipes, serious property damage and/or personal injury. Boiler may shut down. Do not leave your home unattended for long periods of time during freezing weather conditions without turning off the water supply and draining water pipes or otherwise protecting against the risk of frozen pipes.

Your heating boiler is designed to provide a warm and comfortable living environment. It is NOT designed to ensure against freezing of water pipes.

The boiler is equipped with several safety devices that are designed to shut down the boiler and to prevent it from restarting in the event of various unsafe conditions.

If your boiler remains off for an extended period of time during cold weather, water pipes may freeze and burst, resulting in extensive water damage and conditions in which mold could grow. Certain molds are known to cause respiratory problems, as well as to pose other serious health risks. In case of water damage, immediate measures should be taken to dry out affected areas as quickly as possible to prevent mold from developing.

If your home will be unattended for an extended period of time during cold weather, you should...

- Shut off the water supply to the building, drain the water pipes and add an antifreeze for potable water to drain traps and toilet tanks. Open faucets where appropriate.

Or...

- Have someone check the building frequently during cold weather and call a qualified service agency if required.

Or...

- Install a reliable remote temperature sensor that will notify somebody of freezing conditions within the home.

For your Safety *(continued)***WARNING**

If you notice fire coming from the appliance, call the fire department immediately! Do not attempt to extinguish the fire unless qualified to do so.

**WARNING**

Fire causes a risk of burns and explosion!

- Shut down the boiler
 - Close fuel shut-off valves
 - Use a tested fire extinguisher, class ABC.
- Ensure ambient temperatures are higher than 32° F (0° C) and lower than 104° F (40° C).
 - Prevent the air from becoming contaminated by halogenated hydrocarbons (e.g. as contained in paint solvents or cleaning fluids) and excessive dust (e.g. through grinding or polishing work). Combustion air for the heating process, and ventilation of the boiler room must be free of corrosive contaminants. To that end, any boiler must be installed in an area that has no chemical exposure. The list to the right indicates the main, currently known sources.
 - Avoid continuously high levels of humidity (e.g. through frequent drying of laundry).
 - Never close existing ventilation openings.

Replacement components, spare and wear parts**IMPORTANT**

Components which are not tested with the heating system may damage the heating system, or affect its functions. Installation or replacement may only be carried out by a qualified heating contractor.

Installation area conditions**WARNING**

Incorrect ambient conditions can lead to damage to the heating system and put safe operation at risk.

Sources of combustion and ventilation air contaminants.**Areas likely to contain contaminants:**

- New building construction
- Swimming pools
- Remodelling areas, hobby rooms
- Garages with workshops
- Furniture refinishing areas
- Dry cleaning/laundry areas and establishments
- Auto body shops
- Refrigeration repair shops
- Metal fabrication plants
- Plastic manufacturing plants
- Photo processing plants
- Beauty salons

Products containing contaminants:

- Chlorine-type bleaches, detergents and cleaning solvents found in household laundry rooms
- Paint and varnish removers
- Hydrochloric acid, muriatic acid
- Chlorine-based swimming pool chemicals
- Spray cans containing chlorofluorocarbons
- Chlorinated waxes and cleaners
- Cements and glues
- Refrigerant leaks
- Calcium chloride used for thawing
- Sodium chloride used for water softening salt
- Permanent wave solutions
- Adhesives used to fasten building products and other similar items
- Antistatic fabric softeners used in clothes dryers

Overview of Controls and Indicators

Controls and indicators are located behind the hinged front cover. Flip up the front cover to access the controls.

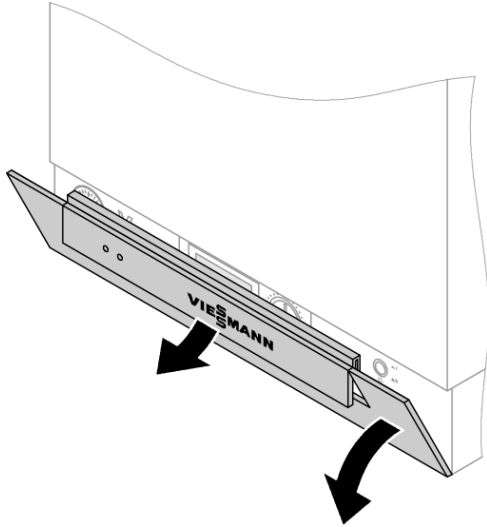

Control and display elements

The control unit is preset at the factory for standard operation. Your heating system is ready for use. The factory presets may be individually adjusted to suit your specific requirements.

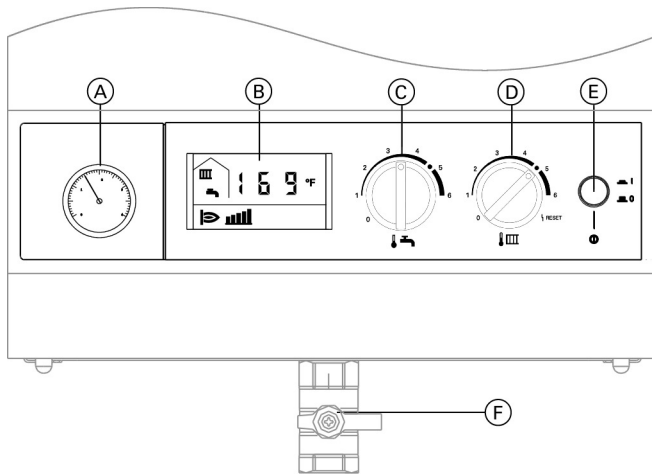

Legend

- (A) Pressure gage
- (B) LCD display
- (C) "🔥" Water temperature, rotary selector (when used with optional CombiPLUS kit only)
- (D) "🔥" Selector dial for boiler water temp.
- (E) ON / OFF switch
- (F) Gas shut-off valve

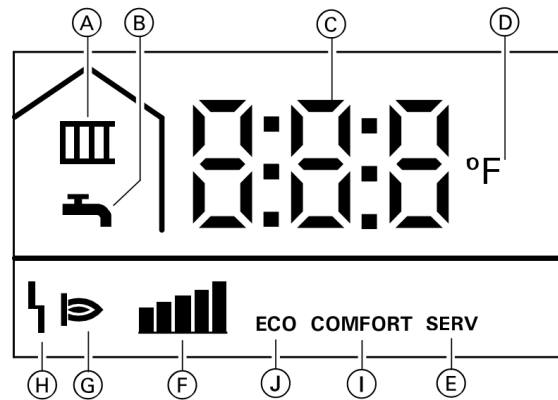

Legend

- (A) Heating mode pump output on
- (B) Pump output on (when DHW contact is closed or when the optional CombiPLUS kit is used)
- (C) Boiler water temperature in °F or fault code
- (D) Units for boiler water temperature measurement
- (E) Service mode
- (F) Current burner firing rate
- (G) Burner in operation
- (H) Fault
- (I) Comfort function started
- (J) Comfort function stopped

Your Vitodens 100 Boiler

Please ask your heating contractor to check off the appropriate box (☒).

Vitodens 100 without domestic hot water tank

The control unit activates and deactivates space heating and supplies rooms with heat.

Vitodens 100 with separate domestic hot water tank

Domestic hot water heating has priority over space heating. The control unit switches automatically to space heating when the preset domestic hot water temperature is reached.

Vitodens 100 with optional CombiPLUS for instantaneous DHW heating

Domestic hot water heating has priority over space heating. The control unit switches automatically to space heating when the heat exchanger temperature is satisfied (with comfort switch on) or when the preset domestic hot water temperature is reached (with comfort switch off).

Changing Room Temperature

In case a separate external room temperature controller (thermostat) is installed, the desired room temperature will be adjusted using this device.

Make adjustments using the appropriate operating instructions only.

Note: If thermostatic radiator valves are installed in the room where the control is installed they must be fully open.

In case the room temperature setting on the separate room temperature controller is not sufficient to achieve the desired room temperature (e.g. during a particularly cold winter), the boiler water temperature can be adjusted accordingly using the boiler water temperature selector dial "🔥 III".

Heating System Operation

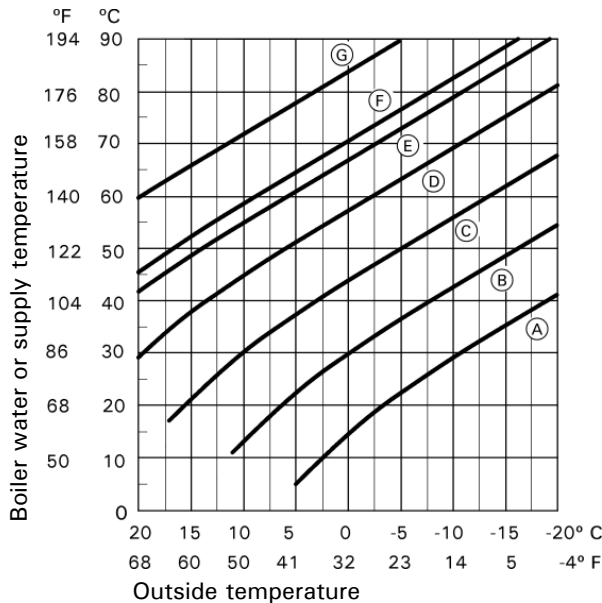
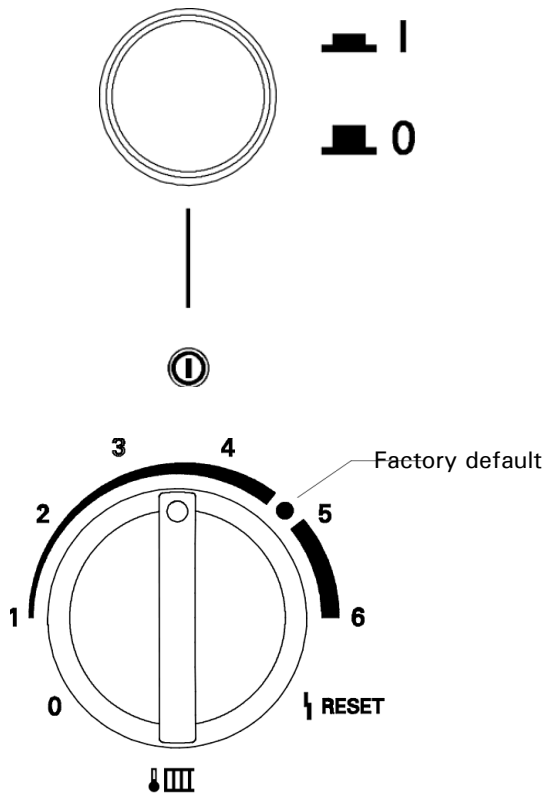

Legend

- (A) Selector dial "🌡️" setting: 1
- (B) Selector dial "🌡️" setting: 2
- (C) Selector dial "🌡️" setting: 3
- (D) Selector dial "🌡️" setting: 4
- (E) Factory default
- (F) Selector dial "🌡️" setting: 5
- (G) Selector dial "🌡️" setting: 6

Switching ON

Room dependent control:

Outdoor temperature sensor *not* connected

With no outdoor sensor installed, the "🌡️" dial will provide a constant temperature set-point for the boiler based on the dial position selected.

Setting the dial between 1 and 6 will provide a set-point value of 81° F to 178° F (27° C to 81° C) respectively. The dot between 4 and 5 represents the factory default set-point value of 140° F (60° C).

Weather dependent control

Outdoor temperature sensor connected

With the outdoor sensor connected, the boiler will automatically recognize the sensor and switch the set-point dial operation from constant temperature calculated to outdoor reset calculated.

Adjusting the "🌡️" dial will select the heating curve corresponding with the heating curve chart. The set-point will be calculated from the design boiler water temperature associated with the heating curve selected, and reset from the actual outdoor air temperature. Setting the dial between 1 and 6 will select the corresponding curve from the chart. The dot between 4 and 5 is the factory default curve.

The display "🌡️" indicates when a heat request has been made.

Note: Both the room dependent control and the outdoor reset control strategies require a closed contact at terminals RT to generate a call for heat to the boiler.

Setting the dial to "0" places the boiler in freeze protection mode regardless of the control option selected or the contact position at RT.

Switching OFF

Turn the selector dial "🌡️" to "0".

Note: If an external OpenTherm device is connected that controls the boiler water temperature, it can no longer be adjusted using the selector dial "🌡️"

Domestic Hot Water

Select the DHW temperature in accordance with your requirements (e.g. for showering).

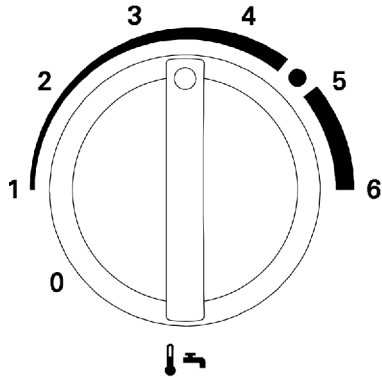



When used with the CombiPLUS, the numbers represent an approximate temperature setting of:

- 0 No DHW
- 1 95° F (35° C)
- 2 105° F (40° C)
- 3 110° F (43° C)
- 4 120° F (49° C)
- 5 125° F (52° C)
- 6 135° F to 140° F (57° C to 60° C)

With CombiPLUS kit only

Switching ON

Move rotary selector “” to the required DHW temperature.

If DHW heating is active, the indicator “” appears on the display.

Switching OFF

Turn rotary selector “” to “0”.

Note: If the boiler is not used with the CombiPLUS kit, turn the rotary selector “” to “0”.

When in operation with a separate Domestic Hot Water (DHW) tank, the domestic hot water temperature is adjusted at the temperature control of the DHW tank.

When heating a domestic hot water tank, external heat demand or used with the CombiPLUS kit, the display shows “”.

The boiler water temperature is automatically adjusted to satisfy the DHW demand.

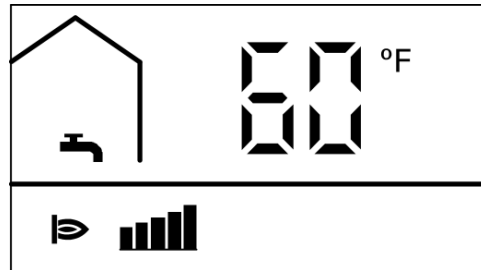

The scalding label is placed on the front of the boiler.

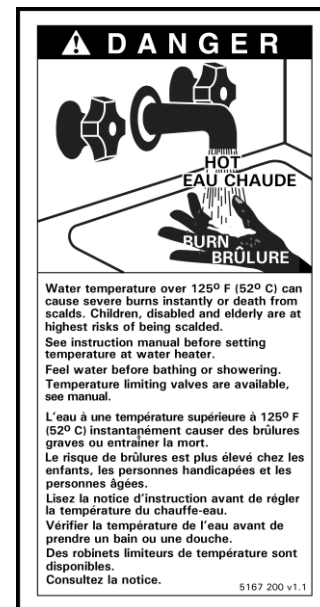

Note: This label must be installed as required by national code.

Comfort Function

If the comfort function is switched ON (when used with the DHW CombiPLUS Kit only), the instantaneous water heater is kept up to temperature (standby). Hot water is therefore quickly available.

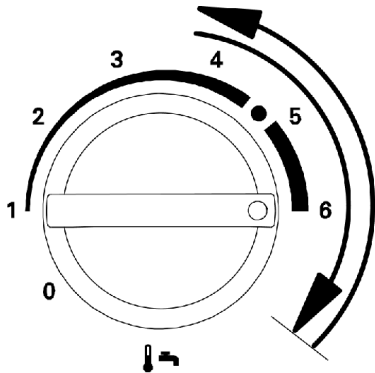

Starting the comfort function

Briefly turn selector “” clockwise as far as possible, wait for SERV to appear momentarily (for less than 3 sec.) then turn it counter clockwise again. “COMFORT” appears on the display.

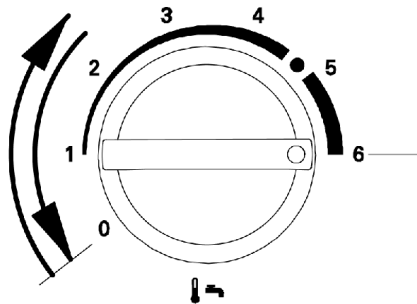

Stopping the comfort function

Briefly turn the rotary selector “” counter clockwise as far as possible, wait for SERV to appear momentarily (for less than 3 sec.) then turn it clockwise again. “ECO” appears on the display.

Heating Water Temperature and System Pressure

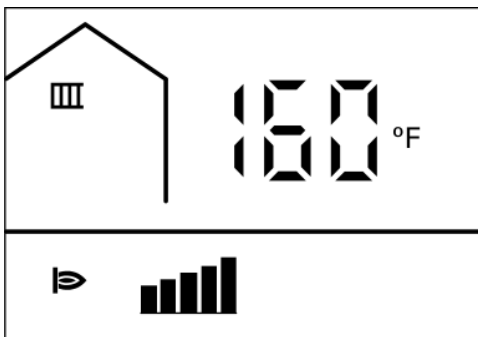

Checking the boiler heating water temperature

During operation, the heating water temperature is constantly displayed.



Checking the system pressure

Check the pressure of your heating system on the pressure gage. Minimum system pressure must be 0.8 bar (12 psi). Notify your heating contractor if the pressure of the system is too low.

Switching OFF Vitodens with Frost Protection

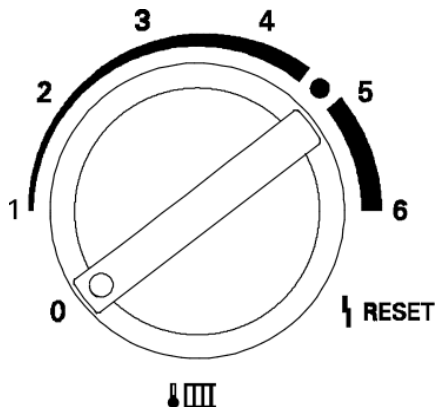

Switch OFF the equipment if you do not wish to use your heating system for a few days.

Turn selector dial "❄️" to "0".
Boiler frost protection is active.

Frost protection

Frost protection is continuously active. The burner is switched ON when the boiler water temperature reaches 41° F (5° C) and is switched OFF again when the boiler water temperature reaches at least 59° F (15° C) but not more than 68° F (20° C).

Shutting Down the Heating System

Shut down your heating system completely, if it is not needed for longer periods of time (several months). Before you switch your heating system OFF for longer periods, it is advisable to contact your local heating contractor. Your heating professional will take any necessary measures, e.g. for freeze protection of the system or to protect the heat emitter surfaces, e.g. radiators etc.

1. Close gas shutoff valve and secure against unintentional opening.
2. Switch OFF line voltage (e.g. at separate fuse/circuit breaker).
The power supply to the system is now switched off.

IMPORTANT

At this point the boiler and the system are no longer protected from freezing.

Fault Diagnosis and Correction

Issue	Cause	Corrective Action
Heating system does not start up	Heating system switch turned to OFF on control unit	Turn switch to ON on control unit.
	Selector dial "📊" is set to "0".	Set required heating water temperature (see page 10).
	Circuit breaker or fuse in power supply or in boiler control unit has blown or tripped	Inform heating contractor.
Burner does not switch on or only intermittently	No gas	Open gas shut-off valve or contact your gas supply company.
	Fault on control unit	Make a note of the fault code and inform heating contractor.
Burner does not start up; burner fault, "🔥" is displayed on control unit	Faulty start-up	Press ON / OFF switch to OFF position and then back ON. This will reset the boiler fault (see page 10). Should this attempt fail, contact your heating contractor.
	Fault on control unit	
Burner does not start up, no fault "🔥" display. "📊" and / or "🔌" on the display	No water flow	Flow switch defective or boiler pump failure. Inform heating contractor.
Burner does not start up; burner fault "🔥" appears in display	Power supply too low	Contact your Hydro company.
The burner switches off even though the desired room temperature has not been reached	Fault in combustion air supply or in the venting system	Contact your heating contractor.
	Heating water temperature or room temperature is set too low	Increase heating water temperature by turning selector dial "📊" or by increasing desired room temperature on the room thermostat.
	Air in heating system	
Rooms are cold although burner is operating	Domestic hot water supply has priority (operation with DHW storage tank only)	Wait until the domestic hot water heating is complete.
	Fault on programmable room thermostat	Contact your heating contractor.
	Circulation pump fault	
Rooms are not at the required temperature, even though the temperature is operating	DHW priority	
	Circulation pump faulty	
DHW temperature is too low	DHW temperature is set too low or rotary selector "🔌" is set to "0" (only with the CombiPLUS kit)	
Fault code "58" appears on the display	Jumper connection shorted out, removed or missing	Contact your heating contractor.

Fault Messages on the Display

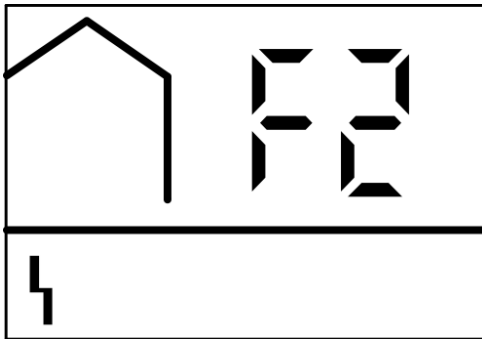

Any faults in your heating system are indicated on the display by a flashing fault symbol "F". Read off the fault code in the display and report it to your heating contractor. This helps the contractor to properly prepare, and may result in lower service costs.

WARNING

Visually inspect the vent termination for any signs of blockage. Under cold climate conditions [sustained temperatures below 0° F (-18° C)] the vent termination may be severely blocked by icicle and frost build-up. The boiler control will automatically shut down the boiler should air intake or vent be blocked. Remove blockage if possible. Reset the boiler switch (ON / OFF switch to OFF and then back to ON) (see page 10) and the boiler should attempt to restart. If blockage is not obvious and cannot be removed, contact a licensed professional heating contractor.

Service Instructions for your Heating System

Viessmann strongly recommends inspection/service of the boiler and the system by a licensed professional heating contractor once per year.

Before the heating season begins, the boiler with its burner(s) and vent system should be serviced by a qualified heating contractor. Service contracts may be established through gas suppliers or other licensed contractors in your area.

Regular inspection/service ensures trouble free, energy-efficient and environmentally friendly heating activity of your heating system.

Boiler

All boilers must be cleaned on a regular basis as debris build-up will result in increased flue gas temperature, and thus in increased energy consumption.

Viessmann domestic hot water storage tank

Inspection and (if necessary) cleaning of the tank must take place within 2 years of initial start-up and every 2 years thereafter.

Cleaning of the inside surfaces of the domestic hot water storage tank, including domestic hot water connections, may only be performed by a licensed professional heating contractor.

Vitocell 100:

Viessmann recommends an annual inspection, and replacement if required, of the consumable anode by a licensed professional heating contractor.

The inspection can be carried out during regular operation of the heating system; shut-down is not required.

The heating contractor measures the protective current with an anode testing instrument.

Drinking water filter (if installed)

For hygienic reasons:

- replace filter element every 6 months on filters which cannot be flushed back, and perform a visual inspection every 2 months,
- flush back reversible flow filters every 2 months.

Notes on operation:

- Ensure boiler room and boiler are clean.
- Regularly check heating system pressure on the pressure gage.; If the system operating pressure gage is indicating a pressure of below 14 psig, the system pressure is too low; in this case, please contact your heating contractor.

IMPORTANT

If a water treatment device (water softener) is installed in the domestic cold water supply to the hot water storage tank, ensure its proper working condition is checked regularly by your heating contractor.

The same applies if a dirt trap or a water filter is installed in the domestic cold water supply. Any of these devices installed in the domestic cold water supply must be flushed out and serviced on a regular basis.



Please follow the manufacturer's instructions.

How to Save Energy

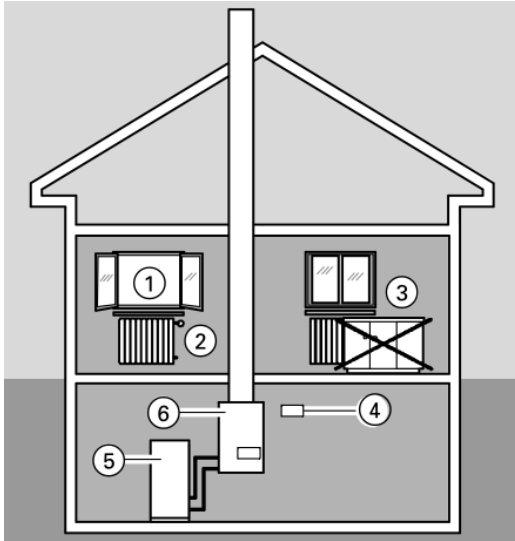

... with regular maintenance

Regular maintenance check-ups of your heating system (6) by a licensed professional heating contractor will ensure energy savings and environmentally friendly operation.

.... with effective insulation

If you wish to make use of additional energy-saving measures, check the thermal insulation:

- of heating and domestic hot water pipes.
- of external walls and the roof.
- between heated and unheated rooms.
- of the windows.

.... by heating the right way

Apart from taking advantage of the benefits of a modern heating system, there is a lot you can do yourself to achieve additional fuel savings.

For instance:

- Don't overheat:
Aim at a room temperature of 68° F (20° C).
Every 2° F (1° C) less in room temperature will reduce your heating bills by up to 6%.
- Close window shutters (if installed) at dusk.
- Operate thermostatic valves (2) correctly.
- Don't obstruct radiators (3) and thermostatic valves (2).
- Make use of individual adjustment options of the control unit (4) (supplied by others);
e.g. "normal room temperature" alternating with "reduced room temperature".
- Set the domestic hot water temperature of the DHW tank (5) on the control unit of the tank or on external controller.
- Control your consumption of hot water:
A shower generally consumes less energy than a bath.

Lighting and Operating Instructions

FOR YOUR SAFETY READ BEFORE OPERATING

W A R N I N G: If you do not follow these instructions exactly, a fire or explosion may result causing property damage, personal injury or loss of life.

- A. This appliance does not have a pilot. It is equipped with an ignition device which automatically lights the burner. Do not try to light the burner by hand.
- B. **BEFORE OPERATING** smell all around the appliance area for gas. Be sure to smell next to the floor because some gas is heavier than air and will settle on the floor.
WHAT TO DO IF YOU SMELL GAS
 - Do not try to light any appliance.
 - Do not touch any electric switch; do not use any phone in your building.
 - Immediately call your gas supplier from a neighbor's phone. Follow the gas supplier's instructions.
 - If you cannot reach your gas supplier, call the fire department.
- C. Use only your hand to push in or turn the gas control knob. Never use tools. If the knob will not push in or turn by hand, don't try to repair it, call a qualified service technician. Force or attempted repair may result in a fire or explosion.
- D. Do not use this appliance if any part has been under water. Immediately call a qualified service technician to inspect the appliance and to replace any part of the control system and any gas control which has been under water.

OPERATING INSTRUCTIONS

1. **STOP!** Read the safety information above on this label.
2. Set thermostat or other operating control to lowest setting.
3. Turn off all electric power to the appliance.
4. This appliance is equipped with an ignition device which automatically lights the burner. Do not try to light the burner by hand.
5. Close main gas shut-off valve.
6. Wait five (5) minutes to clear out any gas. Then smell for gas, including near the floor. If you smell gas, **STOP!** Follow "B" in the safety information above on this label. If you don't smell gas, go to the next step.
7. Open main gas shut-off valve.
8. Turn on all electric power to the appliance.
9. Set thermostat or other operating control to desired setting.
10. If the appliance will not operate, follow the instructions "To Turn Off Gas To Appliance" and call your service technician or gas supplier.

Manual gas shutoff

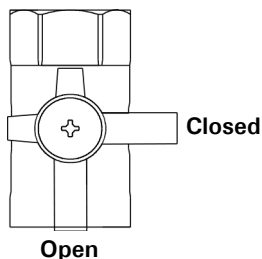

TO TURN OFF GAS TO APPLIANCE

1. Set thermostat or other operating control to lowest setting.
2. Turn off all electric power to the appliance if service is to be performed.
3. Close main gas shut-off valve.

Quick Reference

°C	°F
-40	-40
-35	-31
-25	-13
-20	-4
-18	0
-16	+3
-14	+7
-12	+10
-10	+14
-9	+16
-8	+18
-7	+19
-6	+21
-5	+23
-4	+25
-3	+27
-2	+28
-1	+30
0	+32
+1	+34
+2	+36
+3	+37
+4	+39
+5	+41
+6	+43
+7	+45
+8	+46
+9	+48
+10	+50
+12	+54
+14	+57
+16	+61
+18	+64
+20	+68
+25	+77
+30	+86
+35	+95
+40	+104
+50	+122
+60	+140
+70	+158
+80	+176
+90	+194
+100	+212
+110	+230

Printed on environmentally friendly
(recycled and recyclable) paper.



Technical information subject to change without notice.