

Installation and Service Instructions

for use by heating contractor

Vitorond 100
VR1 Series
Oil-Fired Boiler

Heating input 91 to 140 MBH
27 to 41 kW



VITOROND 100

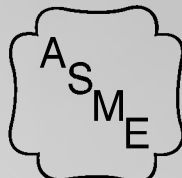

IMPORTANT

Read and save these instructions for future reference.

Safety, Installation and Warranty Requirements

Please ensure that this manual is read and understood before commencing installation. Failure to comply with the issues listed below and details printed in this manual can cause **product/property damage, severe personal injury, and/or loss of life.** Ensure all requirements below are understood and fulfilled (including detailed information found in manual subsections).

■ **Licensed professional heating contractor**

The installation, adjustment, service, and maintenance of this equipment *must be* performed by a licensed professional heating contractor.

► Please see section entitled "Important Regulatory and Installation Requirements."



■ **Contaminated air**

Air contaminated by chemicals can cause by-products in the combustion process which are *poisonous* to inhabitants and destructive to Viessmann equipment.

► For a listing of chemicals which cannot be stored in or near the boiler room, please see section entitled "Combustion Air Supply."



■ **Fresh air**

This equipment requires fresh air for safe operation and must be installed ensuring provisions for *adequate combustion and ventilation air* exist.

► For information pertaining to the fresh air requirements of this product, please see section entitled "Combustion Air Supply."

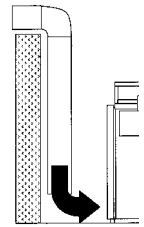

■ **Product documentation**

Read all applicable documentation before commencing installation. Store documentation near boiler in a readily accessible location for reference in the future by service personnel.

► For a listing of applicable literature, please see section entitled "Important Regulatory and Installation Requirements."



■ **Carbon monoxide**

Improper installation, adjustment, service and/or maintenance can cause flue products to flow into living space. Flue products contain *poisonous* carbon monoxide gas.

► For information pertaining to the proper installation, adjustment, service and maintenance of this equipment to avoid formation of carbon monoxide, please see sections entitled "Combustion Air Supply" and "Venting Connection."



■ **Equipment venting**

Never operate boiler without an *installed venting system*. An improper venting system can cause carbon monoxide poisoning.

► For information pertaining to venting and chimney requirements, please see section entitled "Venting Connection." All products of combustion must be safely vented to the outdoors.



■ **Advice to owner**

Once the installation work is complete, the heating contractor must familiarize the system operator/ultimate owner with all equipment, as well as safety precautions/requirements, shut-down procedure, and the need for professional service annually before the heating season begins.

WARNING
Installers must follow local regulations with respect to installation of carbon monoxide detectors. Follow manufacturer's maintenance schedule of boiler.

■ **Warranty**

Information contained in this and related product documentation must be read and followed. *Failure to do so renders warranty null and void.*



Safety, Installation and Warranty Requirements *(continued)*

■ **Fiberglass wool and ceramic fiber materials**

 **WARNING**
Inhalation of fiberglass wool and/or ceramic fiber materials is a possible cancer hazard. These materials can also cause respiratory, skin and eye irritation.

The state of California has listed the airborne fibers of these materials as a possible cancer hazard through inhalation. When handling these materials, special care must be applied.

Suppliers of ceramic fiber products recommend the following first aid measures:

- *Respiratory tract (nose and throat) irritation*
 If respiratory tract irritation develops, move the person to a dust free location.
- *Eye irritation*
 If eyes become irritated, flush immediately with large amounts of lukewarm water for at least 15 minutes. Eyelids should be held away from the eyeball to ensure thorough rinsing. Do not rub eyes.
- *Skin irritation*
 If skin becomes irritated, remove soiled clothing. Do not rub or scratch exposed skin. Wash area of contact thoroughly with soap and water. Using a skin cream or lotion after washing may be helpful.
- *Gastrointestinal irritation*
 If gastrointestinal tract irritation develops, move the person to a dust free environment.

Suppliers of fiberglass wool products recommend the following precautions be taken when handling these materials:

Precautionary measures

- Avoid breathing fiberglass dust and contact with skin and eyes.
- Use NIOSH approved dust/mist respirator.
- Wear long-sleeved, loose fitting clothing, gloves and eye protection.
- Wash work clothes separately from other clothing. Rinse washer thoroughly.
- Operations such as sawing, blowing, tearout and spraying may generate airborne fiber concentration requiring additional protection.

First aid measures

- If eye contact occurs, flush eyes with water to remove dust. If symptoms persist, seek medical attention.
- If skin contact occurs, wash affected areas gently with soap and warm water after handling.

■ **Hazardous materials**

 **WARNING**
Appliance materials of construction, products of combustion and the fuel contain alumina, silica, heavy metals, carbon monoxide, nitrogen oxides, aldehydes and/or other toxic or harmful substances which can cause serious injury or loss of life and which are known to the State of California to cause cancer, birth defects and other reproductive harm. Always use proper safety clothing, respirators and equipment when servicing or working nearby the appliance.

Contents

	Page
Safety	Important Regulatory and Installation Requirements 6
General Information	About these Instructions 7
	Product Information 8
	Mechanical Room 9
Fresh Air	Combustion Air Supply 10
Set-up	Product Delivery 12
	Unpacking Instructions 12
	Minimum Clearances to Combustibles 13
	Recommended Minimum Clearances for Service 14
	Boiler Set-up and Location 14
	Combustion Chamber Insert 15
Connections	Venting Connection 16
	Water Side Connections (with Aquastat Control) 18
	Safety Connections (with Aquastat Control) 19
	Install safety devices on boiler 19
	Water Side Connections (with Vitotronic Control) 21
	Safety Connections (with Vitotronic Control) 22
	Install safety devices on boiler 22
	Pressure Testing 24
Burner (Beckett)	Burner Installation 25
	Burner Information 25
	Burner mounting 26
	Oil piping 27
	Electrical connections (with Aquastat control) 28
	Wiring diagram (with Aquastat control) 30
	Wiring diagram (Vitorond 100 with Beckett burner and Honeywell Aquastat) 31
	Burner Set-up (Beckett) 32
	Electrical connections (with Vitotronic control) 32
	Installation of Vitotronic control 33
	Boiler coding card 35
	Electrical connections (with Vitotronic control) 36
	Wiring diagram (with Vitotronic control) 38
	Wiring diagram (Vitorond 100 with Beckett burner, GeniSys control and Vitotronic control) 39

Burner (Riello)	Burner Installation	40
	Burner Information	40
	Burner Set-up (Riello)	41
	Burner mounting	41
	Oil piping	42
	Electrical connections (with Aquastat control)	43
	Wiring harness connection to Honeywell high limit and Riello burner sub-base (with Aquastat control)	44
	Wiring diagram (with Aquastat control)	45
	Installation of Vitotronic control	46
	Electrical connections (with Vitotronic control)	48
	Wiring diagram (with Vitotronic control)	51
	Boiler coding card	52
Initial Start-up	Initial Start-up	53
	Burner calibration	54
	Beckett burner calibration	55
	Riello burner calibration	56
	Barometric draft regulator	56
Examples	Installation Examples	57
	Installation Examples - Aquastat	58
	Special Applications - Aquastat	59
	Boiler in heating/cooling application	59
	Low water cut-off	59
	Installation Examples - Vitotronic	60
	Special Applications - Vitotronic	62
	Boiler in heating/cooling application	62
	Low water cut-off	62
Service	Service Procedure Overview	63
	Necessary Tools	64
	Service Procedure	64
Additional Information	Parts List	69
	Maintenance Record	
	NO TAG	

Important Regulatory and Installation Requirements

 Take note of all symbols and notations intended to draw attention to potential hazards or important product information. These include "WARNING," "CAUTION," and "IMPORTANT." See page 7 for details.

Codes

The installation of this unit shall be in accordance with local codes. In the absence of local codes, use:

- CSA B-139 for oil installations in Canada
 - NFPA 31 Standard for the Installation of Oil Burning Equipment in the US
- Always use latest editions of codes.

All electrical wiring is to be done in accordance with the latest edition of CSA C22.1 Part 1 and/or local codes. In the U.S. use the National Electrical Code ANSI/NFPA 70. The heating contractor must also conform to the Standard for Controls and Safety Devices for Automatically Fired Boilers, ANSI/ASME CSD-1 where required by the authority having jurisdiction.

→ Please carefully read this manual prior to attempting installation. Any warranty is null and void if these instructions are not followed.

For information regarding other Viessmann System Technology componentry, please reference documentation of the respective product.

We offer frequent installation and service seminars to familiarize our partners with our products. Please inquire.

Mechanical room

Ensure the mechanical room complies with the requirements listed in this manual. See section entitled Mechanical Room on page 10.

Working on the equipment

The installation, adjustment, service, and maintenance of this boiler must be done by a **licensed professional heating contractor** who is qualified and experienced in the installation, service, and maintenance of hot water boilers. There are no end user serviceable parts on the boiler, burner, or control.

→ The completeness and functionality of field supplied electrical controls and components must be verified by the heating contractor. These include low-water cut-offs, flow switches (if used), staging controls, pumps, motorized valves, air vents, thermostats, etc.

Ensure **main power** supply to equipment, the heating system, and all external controls has been **deactivated**. **Close main oil supply valve**. Take precautions in both instances to avoid accidental activation of power during service work.

Technical literature

Literature applicable to all aspects of the Vitorond 100:

- Installation, Service and Operating Instructions
- Installation codes mentioned in this manual

→ Leave all literature at the installation site and advise the system operator/ultimate owner where the literature can be found. Contact Viessmann for additional copies.

→ This product comes with several safety instruction labels attached. Do not remove! Contact Viessmann immediately if replacement labels are required.

About these Instructions

Symbols and flag words used in these instructions

The following symbols and flag words are utilized in these Installation Instructions:

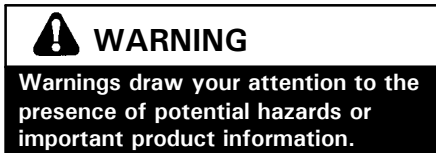

→ *Indicates an imminently hazardous situation which, if not avoided, could result in death, serious injury or substantial product/property damage.*

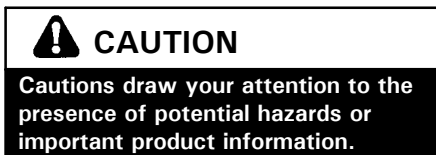

→ *Indicates an imminently hazardous situation which, if not avoided, may result in minor injury or product/property damage.*

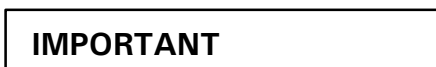

→ *Helpful hints for installation, operation or maintenance which pertain to the product.*

Helpful hints for installation, operation or maintenance which pertain to the product.



→ *This symbol indicates that additional information is written in column 3.*



→ *This symbol indicates that other instructions must be referenced.*

Please note

Viessmann Manufacturing Company Inc. reserves the right to make product changes or updates without notice and will not be held liable for typographical errors or omissions in the product literature.

Product Information

Sectional gray cast-iron boiler with triple-pass design.

For operation in closed loop, forced circulation hot water heating systems. This boiler does not require a flow switch.

The boiler model size selected should be based on an accurate heat loss calculation of the building. The boiler selected must be compatible with the connected radiation.

Maximum adjustable high limit setting (Aquastat):..... 240°F / 110°C
Maximum allowable working pressure ^{*1}: 45 psig / 3 bar
Fuel: #2 fuel oil

**1 Cast iron sections are ASME stamped for 58 psig / 4 bar and maximum allowable temperature of 250°F / 121°C.*

Supply/return bypass for large water content systems

For boilers connected to large water content systems (typically systems with volume > 1 USG / 3.8 ltr for every 13000 Btu/h of boiler input), such as a previous gravity system with large free-standing radiators, a bypass line from the supply pipe to the return pipe must be used to avoid flue gas condensation in the heat exchanger and the vent system. A bypass can be installed on any system as a preventative measure. **Viessmann strongly recommends installing a bypass pipe on all cast iron boilers.**

IMPORTANT

This boiler is equipped with an outdoor reset module that saves energy by reducing the boiler water temperature as the heating load decreases. This feature is equipped with an override which is provided primarily to permit the use of an external energy management system that serves the same function.

THIS OVERRIDE MUST NOT BE USED UNLESS AT LEAST ONE OF THE FOLLOWING CONDITIONS IS TRUE:

- an external energy management system is installed that reduces the boiler water temperature as the heating load decreases.
- This boiler is not used for any space heating.
- This boiler is part of a modular or multiple boiler system having a total input of 300,000 BTU/hr or greater.
- This boiler is equipped with a tankless coil.

Mechanical Room

During the early stages of new home design, we recommend that proper consideration be given to constructing a separate mechanical room dedicated to gas or oil fired equipment including domestic hot water storage tanks.

The boiler should be located in a heated indoor space, near a floor drain, and as close as possible to the vertical chimney or vent.

Install the boiler on a concrete foundation if:

- the floor may be flooded,
- the floor is not level,
- the boiler will be installed in a residential garage (in this case ensure that the burner is raised at least 18" / 457 mm above the floor to avoid contact with flammable vapors and fumes).

Viessmann strongly recommends installing the boiler on a concrete foundation.

Whenever possible install boiler near an outside wall so that it is easy to duct fresh air directly to the boiler area. In addition, do not use exhaust fans in the boiler room and do not install the boiler in rooms with refrigeration equipment. This equipment requires uncontaminated outside air for safe operation - do not install where chemicals are stored or in a room with negative pressure. See section entitled "Combustion Air Supply" for further details regarding the above.

Locate boiler on flooring capable of supporting the weight of the boiler filled with water. Ensure that the boiler location does not interfere with the proper circulation of combustion and ventilation air within the mechanical room.

Combustion Air Supply

Codes

Provisions for combustion and ventilation air must be made in accordance with applicable local codes. In the absence of local codes, use:

- CSA B-139 for oil installations in Canada, or
 - NFPA 31, Standard for the Installation of Oil Burning Equipment in the U.S.
- Always use latest editions of codes.

 **WARNING**

Failure to provide an adequate supply of fresh combustion air can cause poisonous flue gases to enter living space. Flue gases entering living space can cause carbon monoxide poisoning which can result in severe personal injury or loss of life.

 **WARNING**

Never cover the boiler or store debris or other materials near the boiler, or in any way block the flow of adequate fresh air to the boiler. Never cover the combustion air opening. Advise system operator/ultimate owner accordingly.

 **WARNING**

The boiler must not be located in areas or rooms where chemicals are stored, or aggressive vapors (i.e. bleach, hair spray, methyl chloride, carbon tetrachloride or perchloroethylene) or high dust levels or humidity levels are present. Heat exchanger corrosion might occur and reduce the lifetime of the boiler significantly. If above criteria are not properly observed and boiler damage results, any warranty on the complete boiler and related components will be null and void.

General

This equipment requires fresh air for safe operation and must be installed ensuring provisions for adequate combustion and ventilation air exist.

Whenever possible, install boiler near an outside wall so that it is easy to duct fresh air directly to the boiler area.

The boiler location must never be under negative pressure. Exhaust fans, attic fans, or dryer fans may cause air to be exhausted at a rate higher than air can enter the structure for safe combustion.

The heating contractor shall ensure all of the following requirements are met:

- An adequate supply of combustion air must be available to ensure proper combustion.
- Ambient air temperatures must be maintained within safe operating limits.
- When a damper is provided in any opening intended to admit combustion air into the room within which the appliance is installed, the damper shall be interlocked to prevent any burner from starting before the damper is fully open.
- Each duct used to convey air from the outdoors shall have:
 1. A cross-sectional area throughout its length at least equal to the free area of the inlet and outlet openings which it connects,
 2. A minimum dimension of 3" / 76 mm at any cross-section,
 3. When making provision for outside combustion air, the intake shall not be less than 1 ft / 0.3 m above the anticipated snow level for the location.
- The heating contractor must check with local authorities (municipal building department, gas utility) for combustion air requirements particular to the area.

Combustion Air Supply *(continued)*

Unconfined spaces

Where the boiler is located in an unconfined space in a building having insufficient infiltration, additional air for combustion and ventilation shall be obtained from outdoors or from spaces freely communicating with the outdoors. Under these conditions, permanent opening(s) shall be provided so that the total air received through these openings will be at least as much as would be admitted by openings having a total free area of 1 in²/5000 Btu/h or 4.5 cm²/kWh of the total input rating of all oil-fired appliances.

Confined spaces

If the boiler is located in a confined space and that obtains all of its air for combustion and ventilation from within the conditioned space, the building shall be provided with two permanent openings, one near the top of the enclosure and another near the bottom. Each opening shall have a free area of not less than 1 in²/1000 Btu/h or 19.5 cm²/kWh of the total input rating of all appliances in the enclosure, freely communicating with interior areas that have in turn adequate infiltration from the outside.

If the boiler is located in a confined space and that obtains all of its air for combustion and ventilation from outside, the building shall be provided with two permanent openings, one near the top of the enclosure and another near the bottom. Each opening shall communicate directly or by means of ducts with the outdoors or to such spaces (such as a crawl space) that freely communicate with the outdoors, and shall be sized in accordance with the following methods:

- Vertical duct(s) with a free area of not less than 1 in²/4000 Btu/h or 5.5 cm²/kWh of the total input rating of all appliances in the enclosure,
- Horizontal duct(s) with an equivalent length of less than 50 ft / 15 m, having a free area of not less than 1 in²/2000 Btu/h or 11 cm²/kWh of the total input of all appliances in the enclosure,
- Air openings that communicate directly with the outdoors, having a free area of not less than 1 in²/4000 Btu/h or 5.5 cm²/kWh of the total input rating of all appliances in the enclosure.

Louvres and grilles

In calculating free area as specified, consideration shall be given to the blocking effect of louvers, grilles, or screens that protect openings. Screens used shall be not smaller than ¼" / 6 mm mesh and shall be readily accessible for cleaning. If the free area through a design of louvre or grille is known, it shall be used in calculating the size of opening required to provide the free area specified. If the design and free area are not known, it shall be assumed that wood louvres have 20-25% free area and metal louvres and grills have 60-75% free area.

Installation

Install a combustion air opening. Round duct diameters are as follows:

Boiler Model	Model No.	VR1-22	VR1-27	VR1-33
Round duct for combustion air supply *1	Ø"	5	5	6

*1 Round duct diameter given is a **minimum**.
Ensure that all code requirements are met.

Product Delivery

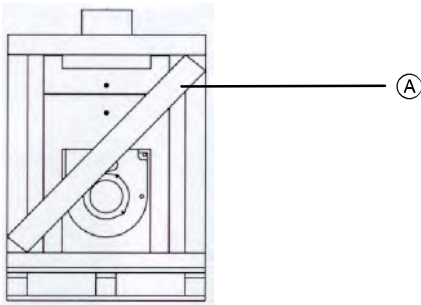

Fig. 1

Vitorond 100 boilers up to size VR1-33 are shipped in a crate with the combustion chamber door and boiler jacketry already mounted.

Product delivery

Ensure each of the following has been delivered:

- Crate with boiler
- Carton with standard installation equipment (A)
- Carton with burner (shipped separately)

Unpacking Instructions

To avoid injury and to facilitate boiler manoeuvring, it is strongly recommended that Viessmann carrying handles (Part No. 7189 602) be used. The carrying handles allow easy removal of boiler from skid and enables easy transportation to permanent location, while reducing the risk of boiler panel damage due to improper lifting or manoeuvring techniques. The carrying handles are designed to prevent boiler slippage onto hands when carrying up/down inclines.

⚠ CAUTION

Do not lift or position boiler alone.
Do not lift by or push against panels.
Do not bump boiler panels against floor.
Do not drop boiler.

If carrying handles are not available, follow the steps below.

Legend

- (A) Casting
- (B) 1" pipe, x2
- (C) Rear wooden block
- (D) Front wooden block

⚠ CAUTION

To avoid injury to hands, place wooden block under pipes in front of skid.

1. Remove top and sides of crate.
To avoid damage during lifting, carefully remove front panel by lifting panel up and out.

2. Place wooden block 12" from rear of skid.

3. Insert 1" Ø pipes through openings in casting legs. Ends of pipes should be centered on wooden block behind skid (Fig. 2).

4. Lift boiler using pipes until clear from skid. Remove skid from beneath boiler (Fig. 3).

5. Lower boiler until pipes rest on front block.

6. To remove rear block, lift (by casting, not jacket) to tilt unit forward.

To remove front block, lift (by casting, not jacket) to tilt unit backward.

7. Remove pipes. Reinstall front boiler panel once boiler is in final position.

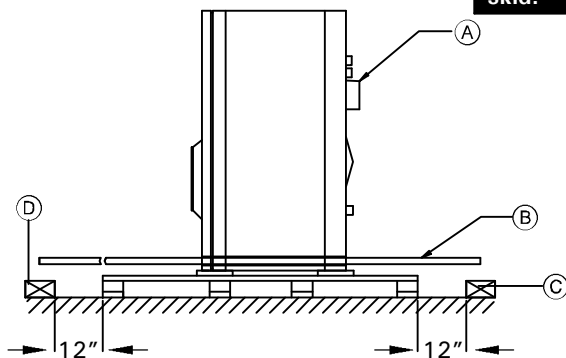

Fig. 2

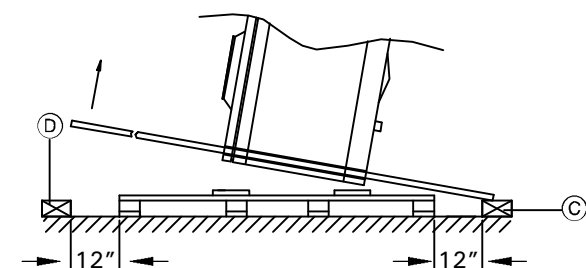

Fig. 3

Minimum Clearances to Combustibles

For typical installations, Viessmann recommends installing the boiler with clearances as published on page 14 under Recommended Minimum Clearances for Service.

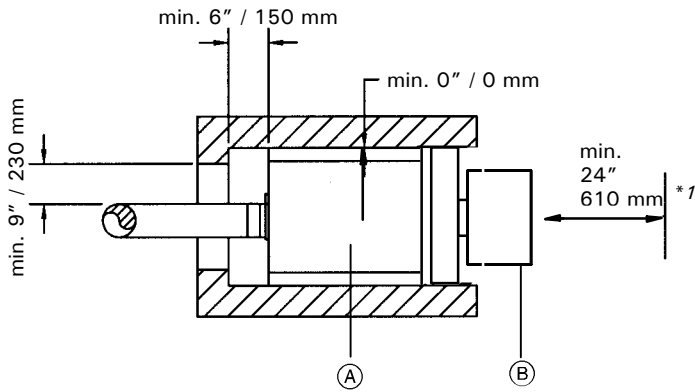

Fig. 4

- Legend**
 (A) Boiler
 (B) Burner

The following are clearances to combustibles:

Standard installation

Boiler Model	VR1	-22	-27	-33
Rear	inches mm	6 150	6 150	6 150
Sides	inches mm	0 0	0 0	0 0
Flue	inches mm	9 230	9 230	9 230
Floor	Combustibles			

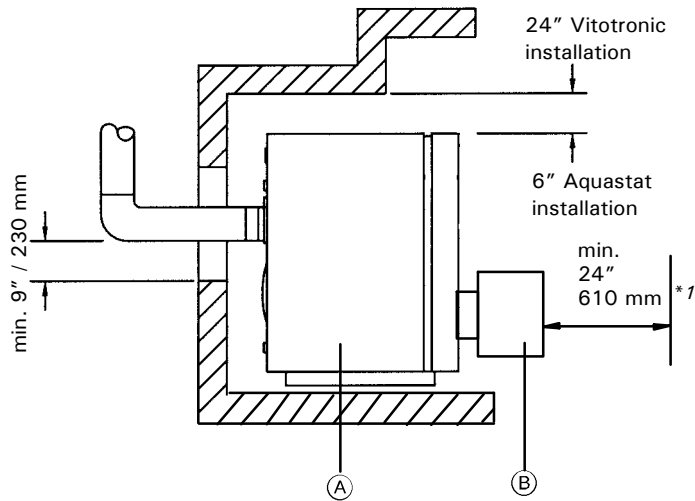

Fig. 5

- Legend**
 (A) Boiler
 (B) Burner

Alcove installation

Boiler Model	VR1	-22	-27	-33
Rear	inches mm	6 150	6 150	6 150
Sides	inches mm	0 0	0 0	0 0
Flue	inches mm	9 230	9 230	9 230
Top*	inches mm	6 150	6 150	6 150
Floor	Combustibles			

*1 Clearance of 24" / 610 mm required for burner service.

Set-up

Recommended Minimum Clearances for Service

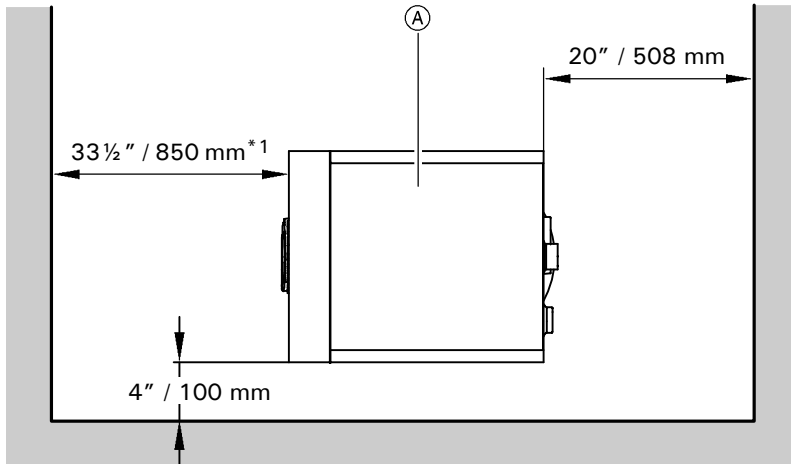

Fig. 6

*1 Minimum access for cleaning and service.

(A) Boiler

Boiler Set-up and Location

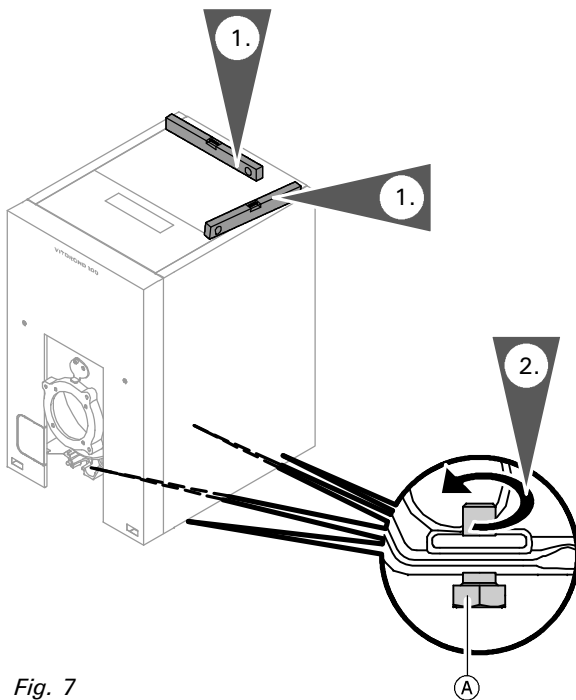

Fig. 7

IMPORTANT

For important information concerning boiler placement and set-up, refer to the section entitled "Mechanical Room" on page 9.

The boiler should be located as close to the chimney as possible.

Set up/locate boiler with slight incline towards the rear of the boiler using levelling bolts (A).

CAUTION

Boiler must be installed in such a way that oil ignition system components are protected from water (spraying, splashing, etc) during boiler system operation and service.

Combustion Chamber Insert

For optimum, environmentally sound operation, Vitorond boilers are equipped with a high-grade, corrosion resistant, stainless steel combustion chamber insert.

Ensure the bolts of the combustion chamber door are tightened before installing the burner

Combustion chamber insert sizes

Boiler Model	VR1	-22	-27	-33
a	inches	9 5/8	9 5/8	9 5/8
	mm	244	244	244
b	inches	9	9	9
	mm	231	231	231

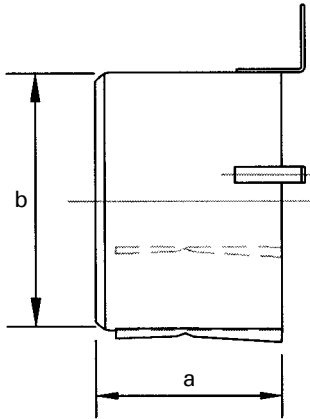

Fig. 8

Venting Connection

Vitorond 100

The vent system must comply with all applicable local and/or national codes.

If installing boiler with a side wall vent system, ensure all manufacturer's requirements are met.

Venting codes

For oil-fired boilers install venting system in accordance with all applicable local codes. In the absence of local codes, follow national codes

- Local codes or CSA B139-00 in Canada, or
- NFPA-31 in the U.S.

Building codes

Masonry or concrete or metal chimneys (smokestacks) shall be constructed according to the requirements of the province/state building code or, in the absence of such regulations, in accordance with:

- CSA Standard CAN/CSA-A405 (National Building Code of Canada) in Canada, or
- NFPA 211 (Standard for Chimneys, Fireplaces, Vents, and Solid Fuel-Burning Appliances) in the US. Metal chimneys also shall meet the requirements of Chapter 4 of NFPA 211.

In Canada, factory built chimneys shall:

- Conform to ULC Standards CAN/ULC-S629 for 1202°F / 650°C, CAN/ULC-S604 for Type A, or CAN/ULC-S609 for Type L chimneys,
- Be certified and installed in accordance with the manufacturer's certified instructions, and
- Be provided with a clean-out opening that is equipped with a tight-fitting removable cap, and constructed so that no air can enter the clean-out facility when the cap is in place.

In the U.S., factory built chimneys shall:

- Meet the requirements of NFPA, and
- Be listed, installed and used in accordance with their listings and manufacturer's instructions.

General

The heating contractor shall ensure all of the following requirements are met:

- The vent system shall ensure that no hazard is created by the products of combustion.
- Provision shall be made to vent the products of combustion safely to outside the building, and such venting shall not pass through or be installed in return air, supply air, ventilating, or combustion air ducts or shafts.
- Sufficient air for combustion of the oil and ventilation of the appliance shall be supplied to the space wherein the appliance is located (see section entitled Combustion Air Supply).
- The house and its mechanical systems shall be inspected to determine if operation of exhaust devices could lead to levels of depressurization of the house that would adversely affect the operation of the oil-burning appliance and its venting system. If such is the case, the building owner shall be informed of the situation in writing.
- The chimney shall be inspected to ensure that the material construction, condition, and size are suitable for the application.
- This boiler/burner combination shall **not** be connected to an unlined chimney. Such chimneys shall be lined in accordance with the applicable codes and standards.
- The chimney shall be capable of exhausting the products of combustion and of producing a draft not less than that recommended by the manufacturer of the appliance connected thereto, during the mildest weather conditions under which the appliance is expected to operate. During cold weather testing, excess flow performance shall be demonstrated to ensure that flow is adequate in warmer weather.
- An oil burning appliance that depends on natural chimney draft shall be connected to an individual chimney vent used for no other appliance, except as permitted by the applicable codes and standards.
- The vent connector of this boiler must not be connected into any portion of mechanical draft systems operating under positive pressure (such as Direct Vent application).

- A chimney flue shall extend at least 3 ft / 1 m above the highest point at which the chimney comes in contact with the roof, and not less than 2 ft / 0.6 m above the highest roof surface or structure within 10 ft. / 3 m of the chimney on a horizontal plane perpendicular to the chimney. Not more than 8" / 200 mm of chimney flue above the top of the chimney cap shall be considered in computing height.
- Down draft and condensation problems must be corrected.



WARNING

Improper sizing, maintenance, termination of vent or chimney can cause flue gases to enter living space. Any blockage of vent or chimney by birds' nests, ice, snow, debris, or other materials can cause flue gases to enter living space. Flue gases entering living space can cause carbon monoxide poisoning which can result in severe personal injury or loss of life.



WARNING

Never operate the boiler/burner without an installed venting system which safely vents all products of combustion to the outdoors. The vent system must comply with all applicable local and/or national codes.

Venting Connection *(continued)*



IMPORTANT

When installing piping or venting, or while insulating overhead pipes, do not stand on top panel of boiler. Advise other trades accordingly!

- Legend**
- (A) Vitorond boiler with burner
 - (B) Outside rain cap
 - (C) Vent, use approved vent material
 - (D) M-Barometric damper (field supplied) for oil*¹
 - (E) Vent pipe adaptor (factory supplied)
 - (F) For Canada: Blocked vent safety switch

*¹ Install in accordance with the draft control manufacturer's instructions.

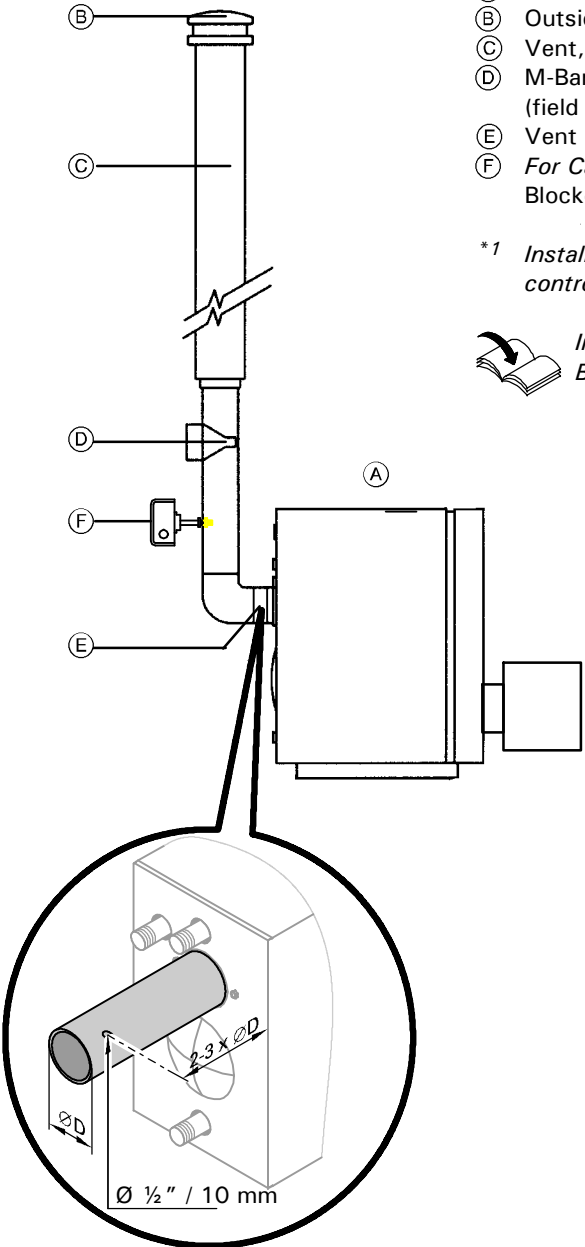
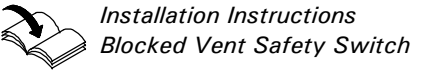

Installation

Use approved vent material only.

1. Install the venting so as to achieve the shortest possible way with minimum elbows. If necessary, rearrange existing water piping to achieve closest chimney connection.
2. Horizontal runs must be supported by appropriate means to prevent sagging. Avoid long horizontal runs of vent pipe. Horizontal runs should have not less than 1/4" rise per ft. from the boiler to the vent terminal. Metal strapping must be used to support horizontal runs every 4 ft.
3. Connect factory supplied vent pipe adaptor (E) to flue gas collar. Fasten using either three equally spaced, corrosion resistant, self-tapping screws and high temperature silicone, or equivalent means.
4. Connect chimney via a 18" / 457 mm long field supplied, slightly inclined intermediate section of venting. Flue pipe outside Ø: 5".
5. Drill a 1/2" opening on the side of the vent pipe approximately three times the vent pipe diameter away from the flue gas collar of the boiler for flue gas analysis equipment.
6. Seal all flue pipe joints.
7. Viessmann recommends that any non-insulated vent pipe is insulated to reduce cooling of flue gas and velocity noises.

For direct vent application, please refer to the Direct Vent System Installation Instructions, Part No. 5351 050.

Water Side Connections (with Aquastat Control)

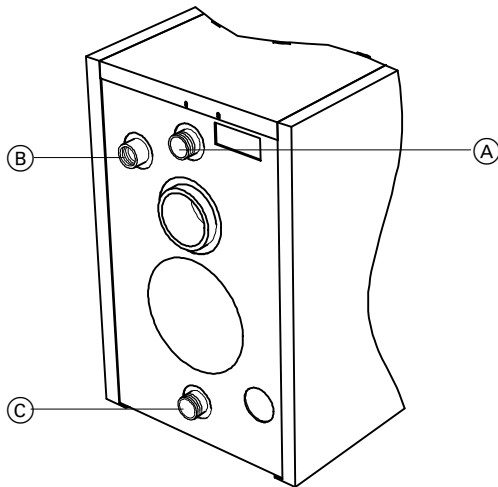

Legend

- (A) Boiler water supply connection, pressure relief valve 1 1/2" NPT
- (B) High limit control location 1 1/4" NPTF
- (C) Boiler water return, drain and automatic feed 1 1/2" NPT

Fig. 10

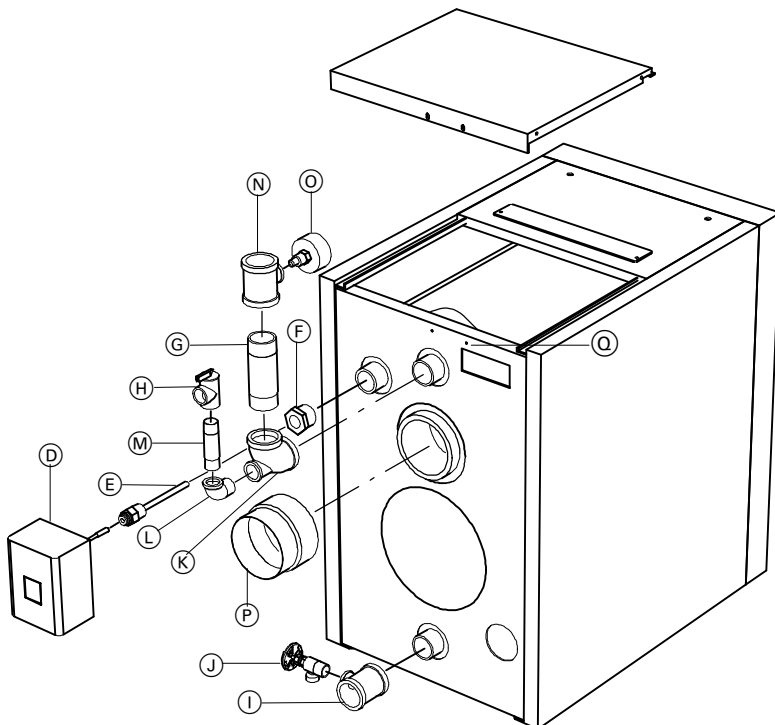

Fig. 11

Legend

- | | |
|---|--|
| (D) Honeywell high limit control | (K) Reducing tee/elbow, 1 1/2" x 3/4" x 1 1/2" |
| (E) Immersion well | (L) Street elbow, 3/4" |
| (F) Hex bushing, 1 1/4" x 3/4" | (M) Nipple, 3/4" x 3 1/2" |
| (G) Nipple, 1 1/2" x 5" | (N) Reducing tee, 1 1/2" x 1 1/2" x 1/2" |
| (H) Pressure relief valve | (O) Temperature and pressure gage |
| (I) Tee, 1 1/2" x 1 1/2" x 3/4" | (P) Flue gas adaptor, Ø 5" |
| (J) Drain valve (sediment faucet), 3/4" | |

IMPORTANT

This boiler is designed for closed loop, forced circulation heating systems only.

1. Flush heating system thoroughly (particularly with existing systems which have been in operation for years).

CAUTION

Failure to flush the heating system could cause system sludge to settle in the boiler, causing overheating and failure. This type of failure is not covered under warranty.

IMPORTANT

We recommend the installation of a spring-loaded flow-check valve in heating circuits without mixing valves. This serves to avoid uncontrolled gravity circulation of heat into the heating system during summer months.

2. Remove screw (Q).
Remove top back panel before starting to connect pipe fittings to boiler water supply connection.
3. Connect system supply to (A) using NPT fittings, as shown in Fig. 11. Connect the system return to (C) using NPT fittings, as shown in Fig. 11.
See installation examples starting on page 52.
4. Install temperature and pressure gage (O) with brass extension coupling in 1/2" opening as shown in Fig. 11. Use thread sealing compound such as Loctite or Teflon tape.

Safety Connections (with Aquastat Control)

Install safety devices on boiler

■ Pressure relief valve

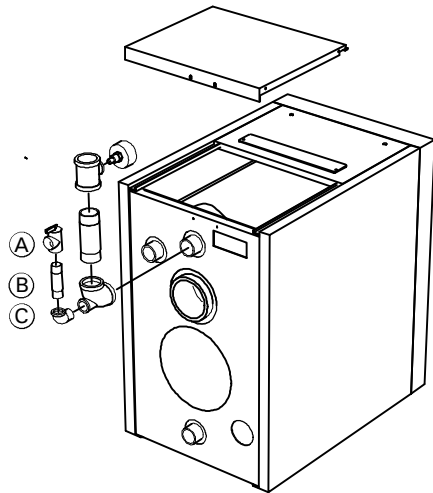

Fig. 12

Legend

- (A) Pressure relief valve
- (B) Nipple, 3/4" x 3 1/2"
- (C) Tee, 1 1/2" x 3/4" x 1 1/2"

1. Install pressure relief valve. Pipe pressure relief valve as illustrated and connect to boiler water supply connection.



Instructions supplied with pressure relief valve.

2. Install discharge pipe on pressure relief valve. The discharge pipe should terminate approximately 6" / 150 mm above a floor drain. The end of the pipe must not be threaded.

Minimum connection diameters:

Pressure relief valve	3/4"
Discharge pipe	3/4"
Piping to precharged expansion tank	
VR1-22 to VR1-33	3/4"

This boiler does **not** require a flow switch.

IMPORTANT

Install the (approved) factory supplied pressure relief valve.

Removal of air from the system must occur via use of air vent(s) in the system supply. To ensure the boiler can be purged of all air, ensure supply/return water lines do not contain restrictive piping where air could be trapped.

⚠ WARNING

Do not install an isolation valve between boiler and pressure relief valve. The discharge pipe for the pressure relief valve must be oriented to prevent scalding of attendants. Pipe pressure relief valve discharge pipe close to floor drain. Never pipe discharge pipe to the outdoors.

■ Boiler control

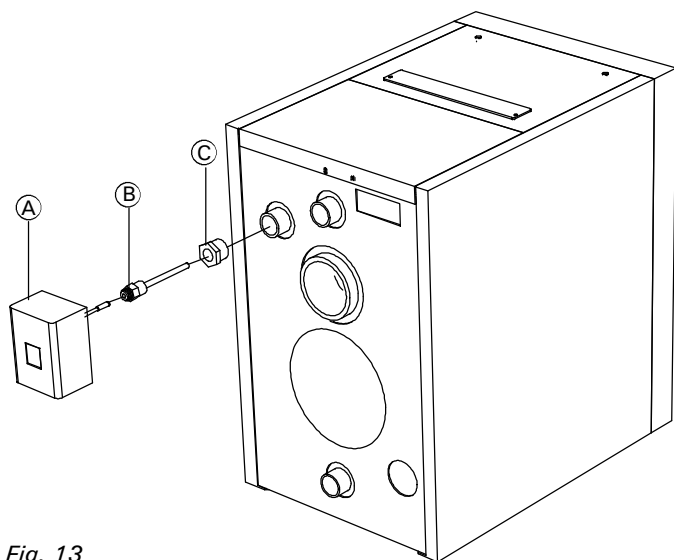

Fig. 13

1. Install supplied high limit control as shown in Fig. 13.

Maximum allowable temperature setting is 240°F / 110°C.



Instructions supplied with Honeywell aquastat.

Legend

- (A) Honeywell high limit control, 7248C1006
- (B) Immersion well
- (C) Hex bushing

Safety Connections (with Aquastat Control) *(continued)*

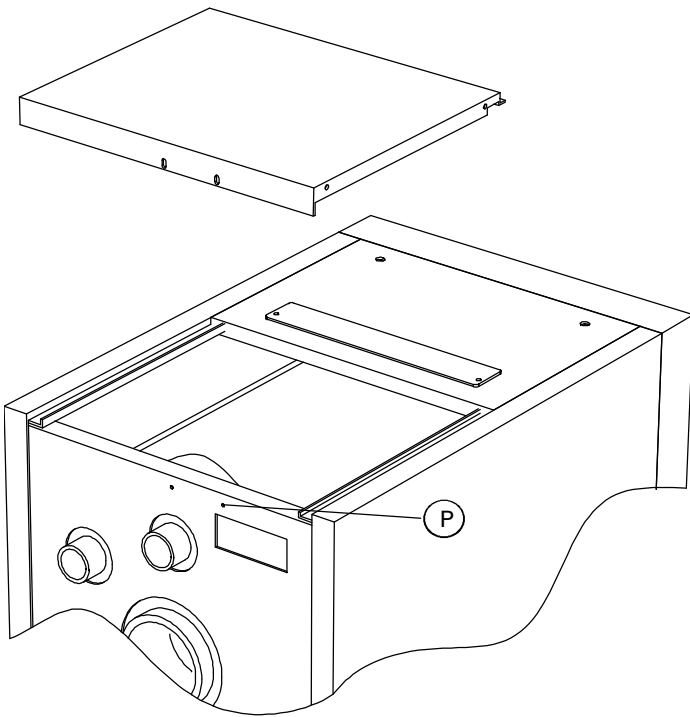



Fig. 14

1. To avoid problems with removing the top panel, we recommend moving the top panel screw approximately 3" to the left or right.

To do this, pre-drill the panels with an $\frac{1}{8}$ " drill bit. To reinstall the top panel, drill a new $\frac{1}{8}$ " pilot hole through the top back panel and into the back panel. Reinstall the screw  into this new mounting hole.

Water Side Connections (with Vitotronic Control)

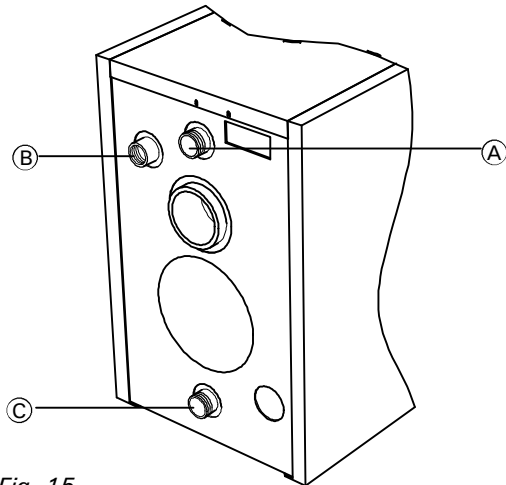

Fig. 15

Legend

- Ⓐ Boiler water supply connection, pressure relief valve 1 ½" NPTM
- Ⓑ Boiler water return with return injector nozzle 1 ½" NPTM
- Ⓒ Safety return; connect precharged expansion tank, boiler drain, and automatic feed 1 ½" NPTM

IMPORTANT

This boiler is designed for closed loop, forced circulation heating systems only.

1. Flush heating system thoroughly (particularly with existing systems which have been in operation for years).

CAUTION

Failure to flush the heating system could cause system sludge to settle in the boiler, causing overheating and failure. This type of failure is not covered under warranty.

IMPORTANT

We recommend the installation of a spring-loaded flow-check valve in heating circuits without mixing valves. This serves to avoid uncontrolled gravity circulation of heat into the heating system during summer months.

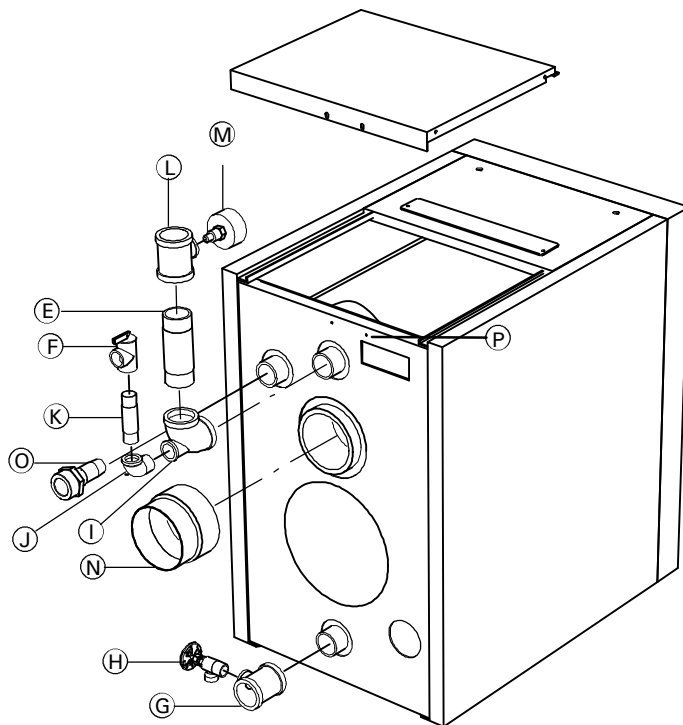

Fig. 16

Legend

- Ⓔ Nipple, 1 ½" x 5"
- Ⓕ Pressure relief valve
- Ⓖ Tee, 1 ½" x 1 ½" x ¾"
- Ⓗ Drain valve (sediment faucet), ¾"
- Ⓘ Reducing tee/elbow, 1 ½" x ¾" x 1 ½"
- Ⓙ Street elbow, ¾"
- Ⓚ Nipple, ¾" x 3 ½"
- Ⓛ Reducing tee, 1 ½" x 1 ½" x ½"
- Ⓜ Temperature and pressure gage
- Ⓝ Flue gas adaptor, Ø 5"
- Ⓞ Return injector

2. Remove screw Ⓔ .
Remove top back panel before starting to connect pipe fittings to boiler water supply connection.
3. Connect system supply to Ⓐ using NPT fittings, as shown in Fig. 16. Connect the system return to Ⓑ using NPT fittings. See installation examples starting on page 52.
4. Install temperature and pressure gage with brass extension coupling Ⓜ in ½" opening as shown in the illustration, as shown in Fig. 16. Use thread sealing compound such as pipe dope or Teflon tape.

Safety Connections (with Vitotronic Control)

Install safety devices on boiler

■ **Pressure relief valve**

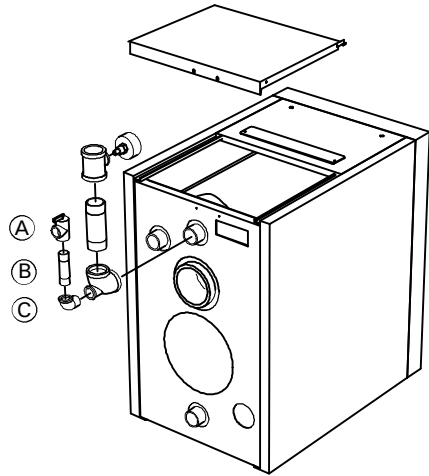
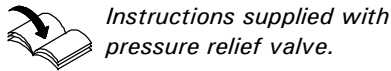

Fig. 17

Legend

- (A) Pressure relief valve
- (B) Nipple, 3/4" x 3 1/2"
- (C) Tee, 1 1/2" x 3/4" x 1 1/2"

1. Install pressure relief valve. Pipe pressure relief valve as illustrated and connect to boiler water supply connection.



2. Install discharge pipe on pressure relief valve. The discharge pipe should terminate approximately 6" / 150 mm above a floor drain. The end of the pipe must **not** be threaded.

Minimum connection diameters:

Pressure relief valve	3/4"
Discharge pipe	3/4"
Piping to precharged expansion tank	
VR1-22 to VR1-33	3/4"

This boiler does **not** require a flow switch.

IMPORTANT

Install the (approved) factory supplied pressure relief valve.

Removal of air from the system must occur via use of air vent(s) in the system supply. To ensure the boiler can be purged of all air, ensure supply/return water lines do not contain restrictive piping where air could be trapped.

⚠ WARNING

Do not install an isolation valve between boiler and pressure relief valve.
The discharge pipe for the pressure relief valve must be oriented to prevent scalding of attendants.
Pipe pressure relief valve discharge pipe close to floor drain. Never pipe discharge pipe to the outdoors.

■ **Boiler return injector**

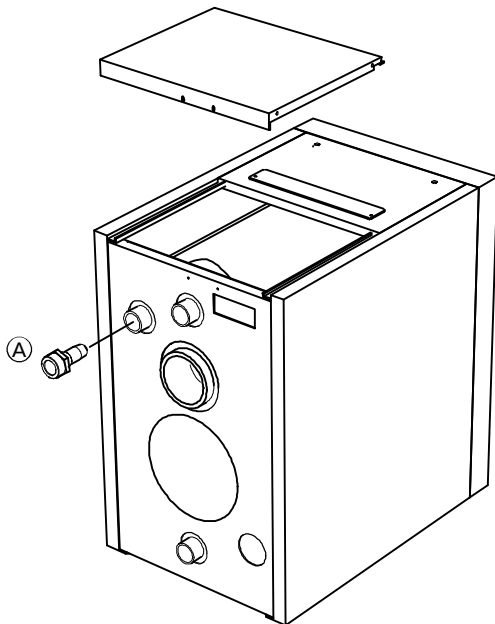

Fig. 18

1. Install bushing/return water injector combination (A).

Safety Connections (with Vitotronic Control) *(continued)*

Fig. 19

1. To avoid problems with removing the top panel, we recommend moving the top panel screw approximately 3" to the left or right. To do this, pre-drill the panel with an $\frac{1}{8}$ " drill bit. To reinstall the top panel, drill a new $\frac{1}{8}$ " pilot hole through the top back panel and into the back panel. Reinstall the screw (P) into this new mounting hole.

Pressure Testing

Perform pressure test on boiler

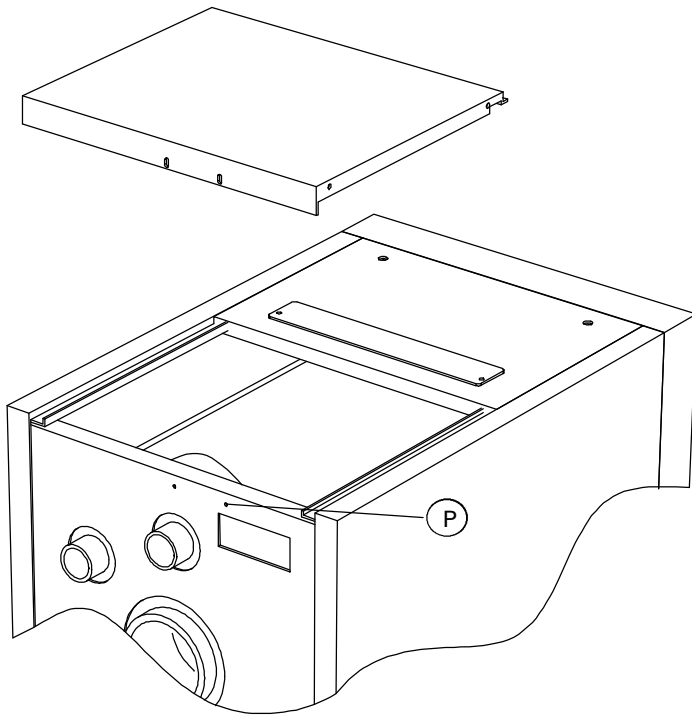
The boiler must be leak tested before being placed in operation. Before boiler is connected to piping or electrical power supply, it must be hydrostatically pressure tested with a maximum of 1 ½ times the maximum operating pressure of the boiler.

1. After installing safety devices, install temporary cap on ¾" nipple extension (nipple for pressure relief valve mounting).
2. Cap supply and return connections.
3. Connect ½" garden hose to boiler drain valve and fill boiler slowly until pressure gage indicates max. 68 psig / 465 kPa.
4. Maintain pressure for 15 minutes. During time of pressure testing, do not leave boiler unattended.
5. Inspect all pipe joint connections, the safety devices (Safety Header, if applicable), and boiler base with flashlight for leaks.
6. After 15 minutes, release water pressure from boiler by opening boiler drain valve slowly, remove caps from supply and return connections as well as ¾" cap from safety nipple, and install pressure relief valve immediately instead of ¾" cap.

After boiler has passed pressure test, proceed with installation.

Max. allowable operating pressure
..... 45 psig / 310 kPa
Max. allowable testing pressure
..... 68 psig / 465 kPa
Max. allowable boiler temperature
..... 248°F / 120°C

 WARNING
Exposing the boiler to pressures and temperatures in excess of those listed will result in damages, and will render warranty null and void.

Burner Installation (Beckett)



*Instructions supplied
with Beckett burner*

Observe all instructions supplied with the burner.

Burner Information

Fuel

This boiler is for use with the Beckett #2 fuel oil burner supplied by Viessmann only. Use only the fuel stated on the rating plate of the burner.

Oil nozzle

The Beckett burner for the VR1-22, -27 and -33 boiler is shipped with factory setting and oil nozzle installed.

For Beckett burner specifications see table on page 55.

Burner calibration

Ensure that the combustion results of the oil-fired burner mounted on this boiler are verified after start-up.

If adjustments are necessary, always verify results with a calibrated flue gas analyzer.

For Beckett burner specifications see table on page 55.



WARNING

**DO NOT USE GASOLINE
CRANKCASE DRAININGS OR ANY
OIL CONTAINING GASOLINE.**

IMPORTANT

This burner is shipped with the oil pump set to operate on a single line system. To operate on a two-line system, the bypass plug must be installed. The burner is shipped configured for use in single line applications. No changes to the oil pump are required for use in single line applications.

Burner Set-up (Beckett)

Burner mounting

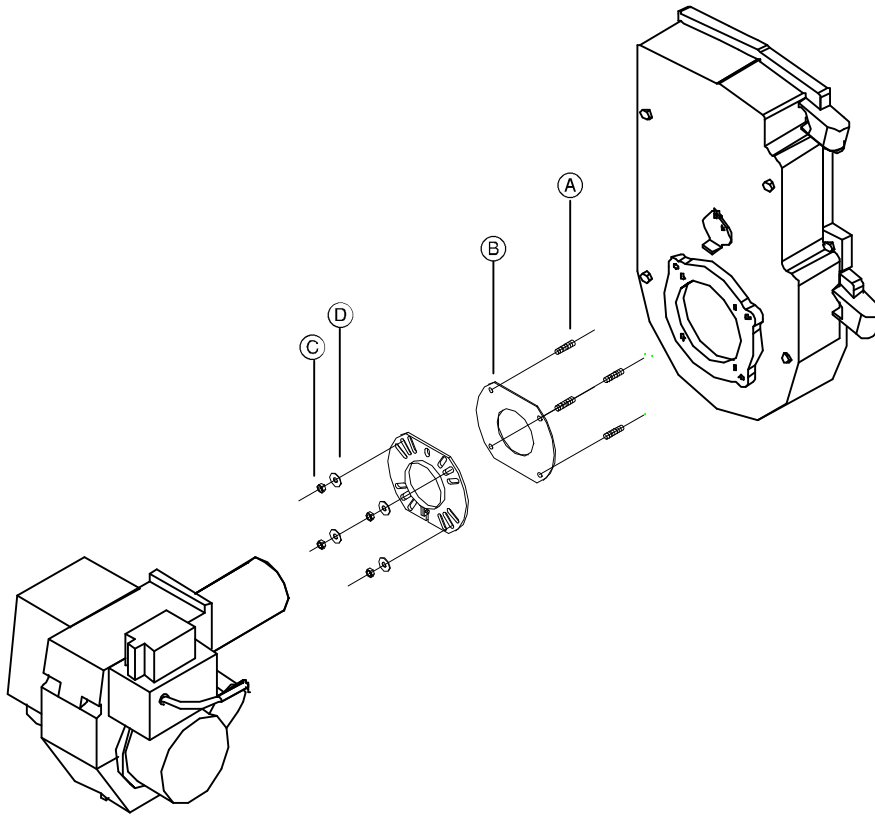

Fig. 20
Burner mounting



Instructions supplied with
Beckett burner.

1. Remove burner from carton. The mounting flange has been installed at the factory.
2. Mount four M8 spacer bolts (A) in threaded holes of combustion chamber door.
3. Slide burner gasket (B) over spacer bolts.
4. Mount burner as shown.
(For proper insertion lengths see table on page 55).
5. Secure burner with M8 nuts (C) and washers (D) provided.

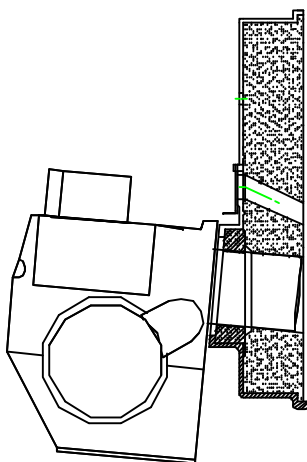

Fig. 21
Burner air tube insertion

Burner Set-up (Beckett) *(continued)***Oil piping**

Fig. 22
Oil piping connection

Legend

- Ⓐ Oil line (see local codes for appropriate arrangement and piping of filter control valves, etc., back to oil tank)
- Ⓑ Flare fitting

IMPORTANT

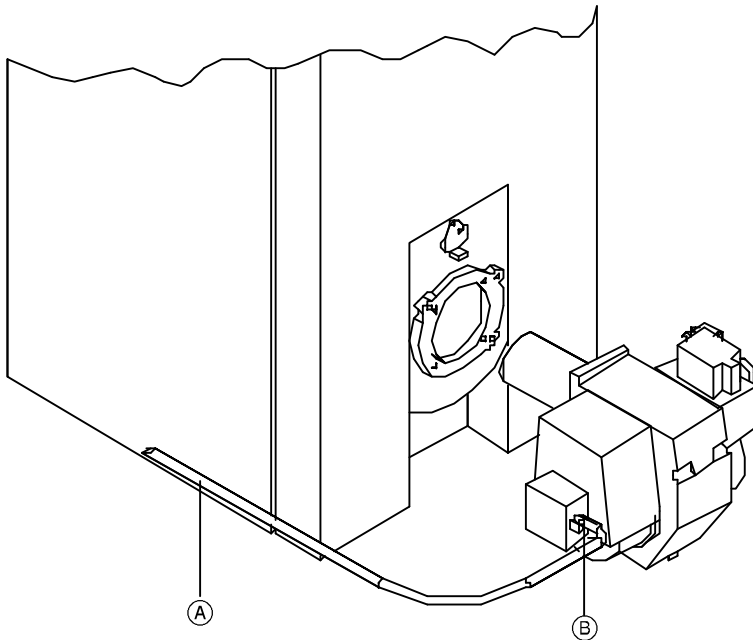
This burner is shipped with the oil pump set to operate on a single line system. To operate on a two-line system, the bypass plug must be installed. The burner is shipped configured for use in single line applications. No changes to the oil pump are required for use in single line applications.

General oil piping requirements

Location and installation of oil tanks, oil piping and burners must follow:

- Local codes and regulations.
- Information provided with burner and fuel pump.
- In Canada, CSA B139, Installation of Oil-Burning Equipment.
- In USA, NFPA 31, Standard for the Installation of Oil-Burning Equipment.

⚠ WARNING

Do not use Teflon tape as an oil pipe sealant. It can cause valves to fail, creating hazards. Do not use compression fittings.

Underground oil line piping must be encased to prevent oil leaking into ground. Check local codes for information.

If any part of fuel oil tank is above burner level, an anti-siphon device must be used to prevent flow of oil in case of oil line break.

Make tank connections with swing joints or copper tubing to prevent breaking in case the tank settles. Make swing joints so they will tighten as tank settles. Non-hardening pipe joint compounds should be used on all threads.

Support oil lines as required by codes.

Oil piping connection at burner

See illustration above for recommended connection at burner, allowing burner mounting door to swing open completely for servicing.

⚠ WARNING

The oil supply inlet pressure to the fuel unit cannot exceed 3 psig. Install a pressure-limiting device in accordance with the above mentioned codes.

Burner Set-up (Beckett) *(continued)*

Electrical connections (with Aquastat control)

! WARNING
 Electric shock hazard. Can cause severe personal injury or loss of life if power source, including service switch on boiler, is not disconnected before installing or servicing.

Installations must follow these codes and requirements:

- National Electrical Code, ANSI/NFPA 70, latest edition and any additional national, state or local codes.
- In Canada, CSA C22.1 Canadian Electrical Code Part 1 and any local codes.

- Wiring must be N.E.C. Class 1. If original wire as supplied with boiler must be replaced, type 105°C wire or equivalent must be used. Supply wiring to boiler and additional control wiring must be 14 ga. or heavier.
- Provide electrical ground at boiler as required by codes.

- ▶ All field supplied nominal 120 VAC voltage wiring must be sheathed in a flexible metal conduit.
- ▶ Disconnect means, overload protection and low water cut-off must be provided as required by local codes.
- ▶ Connect incoming line voltage HOT (L1) wire to terminal L1, and N to terminal L2 of the Honeywell high limit control (see wiring diagram on page 31).

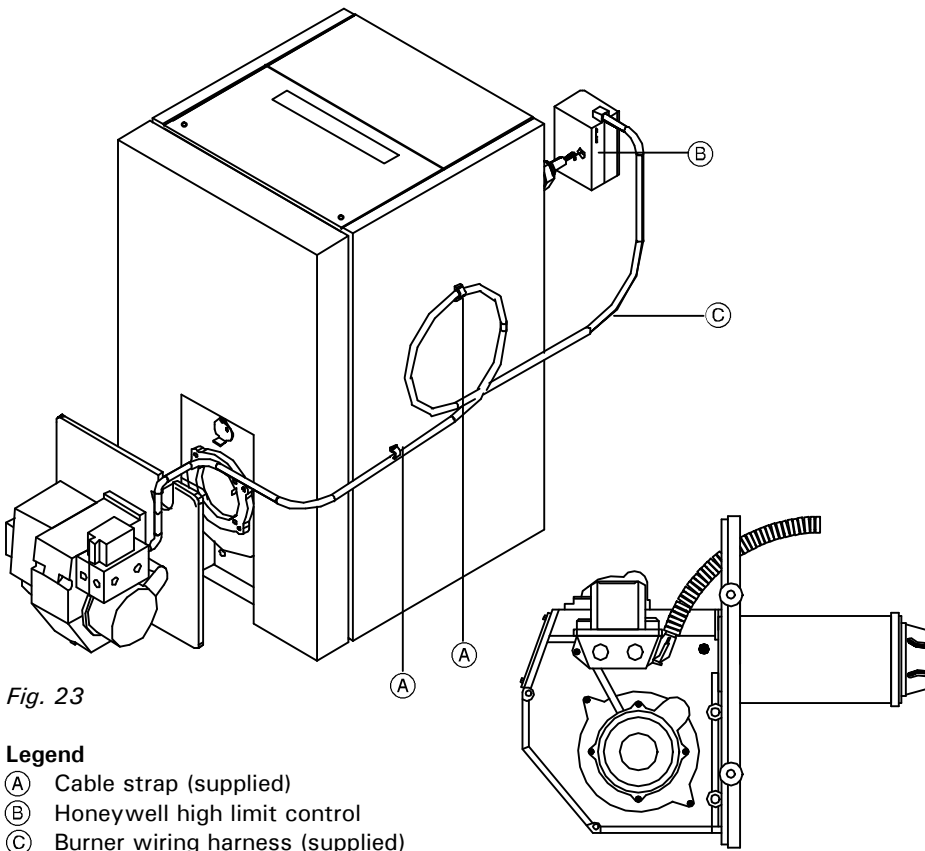

Fig. 23

Legend

- (A) Cable strap (supplied)
- (B) Honeywell high limit control
- (C) Burner wiring harness (supplied)

! WARNING
 Ensure that burner wiring harness is properly attached and secured to the boiler side panel using the supplied cable straps as depicted above. The cable strap must be coiled on the boiler side panel so that no slack is left, allowing the burner/boiler door to be swung open without disconnecting the burner wiring harness from the burner. Failure to heed this warning may result in personal injury.

Burner wiring

IMPORTANT

The R7184 or GeniSys 7505P primary control with valve-on delay (pre-purge) and burner motor-off delay (post-purge - factory default settings can be field adjusted), requires a constant 120 VAC power source supplied to the BLACK wire on the control (see wiring diagram on following page).

1. The cover mounting plate is not a conduit connection point. Pass conduit and attached connector through the front opening in the mounting plate or through one of the knockouts on either side of the cover and attach it directly to the burner-mounted 4x4 electrical junction box.

Room thermostat wiring

1. Install thermostat on inside wall away from influences of drafts, hot or cold water pipes, lighting fixtures, television, sun rays or fireplaces.
2. Follow instructions supplied with room thermostat. If it has a heat anticipator, set heat anticipator in thermostat to match power requirements of equipment connected to it. Boiler wiring diagrams give setting for standard equipment.

Burner Set-up (Beckett) *(continued)*

Electrical connections (with Aquastat control) *(continued)*

! WARNING

Electric shock hazard. Can cause severe personal injury or loss of life if power source, including service switch on boiler, is not disconnected before installing or servicing.

Installations must follow these codes and requirements:

- National Electrical Code, ANSI/NFPA 70, latest edition and any additional national, state or local codes.
- In Canada, CSA C22.1 Canadian Electrical Code Part 1 and any local codes.

- Wiring must be N.E.C. Class 1. If original wire as supplied with boiler must be replaced, type 105°C wire or equivalent must be used. Supply wiring to boiler and additional control wiring must be 14 ga. or heavier.
- Provide electrical ground at boiler as required by codes.

Burner wiring harness (supplied)

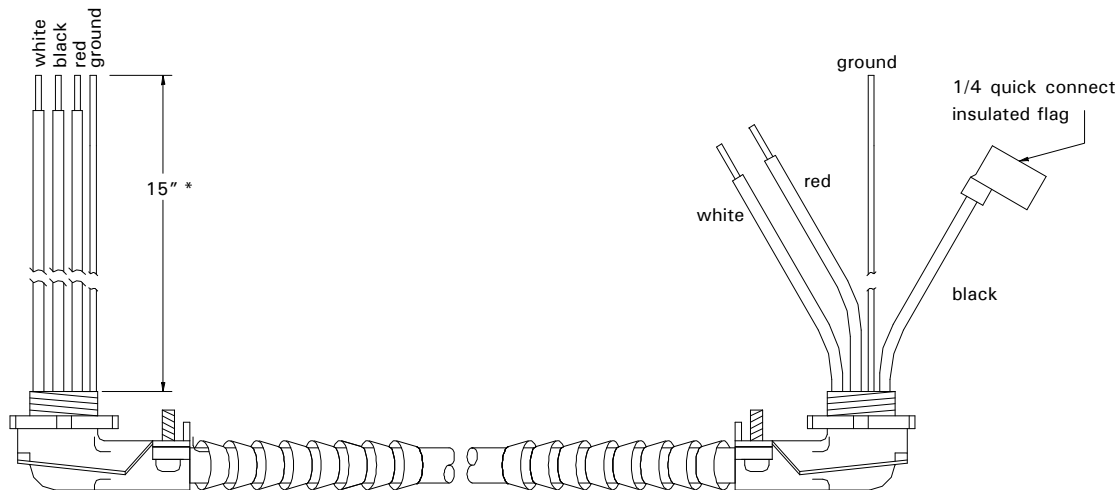

Fig. 24

* If Beckett burner is being installed, cut this length to 6" for connection to burner junction box (located under the burner primary control).

Burner Set-up (Beckett) *(continued)*

Wiring diagram (with Aquastat control)

⚠ WARNING
Electric shock hazard. Can cause severe personal injury or loss of life if power source, including service switch on boiler, is not disconnected before installing or servicing.

Installations must follow these codes and requirements:

- National Electrical Code, ANSI/NFPA 70, latest edition and any additional national, state or local codes.
- In Canada, CSA C22.1 Canadian Electrical Code Part 1 and any local codes.

- Wiring must be N.E.C. Class 1. If original wire as supplied with boiler must be replaced, type 105°C wire or equivalent must be used. Supply wiring to boiler and additional control wiring must be 14 ga. or heavier.
- Provide electrical ground at boiler as required by codes.

- ▶ All field supplied nominal 120 VAC voltage wiring must be sheathed in a flexible metal conduit.
- ▶ Disconnect means, overload protection and low water cut-off must be provided as required by local codes.
- ▶ Connect incoming line voltage HOT (L1) wire to terminal L1, and N to terminal L2 of the Honeywell high limit control (see wiring diagram below).

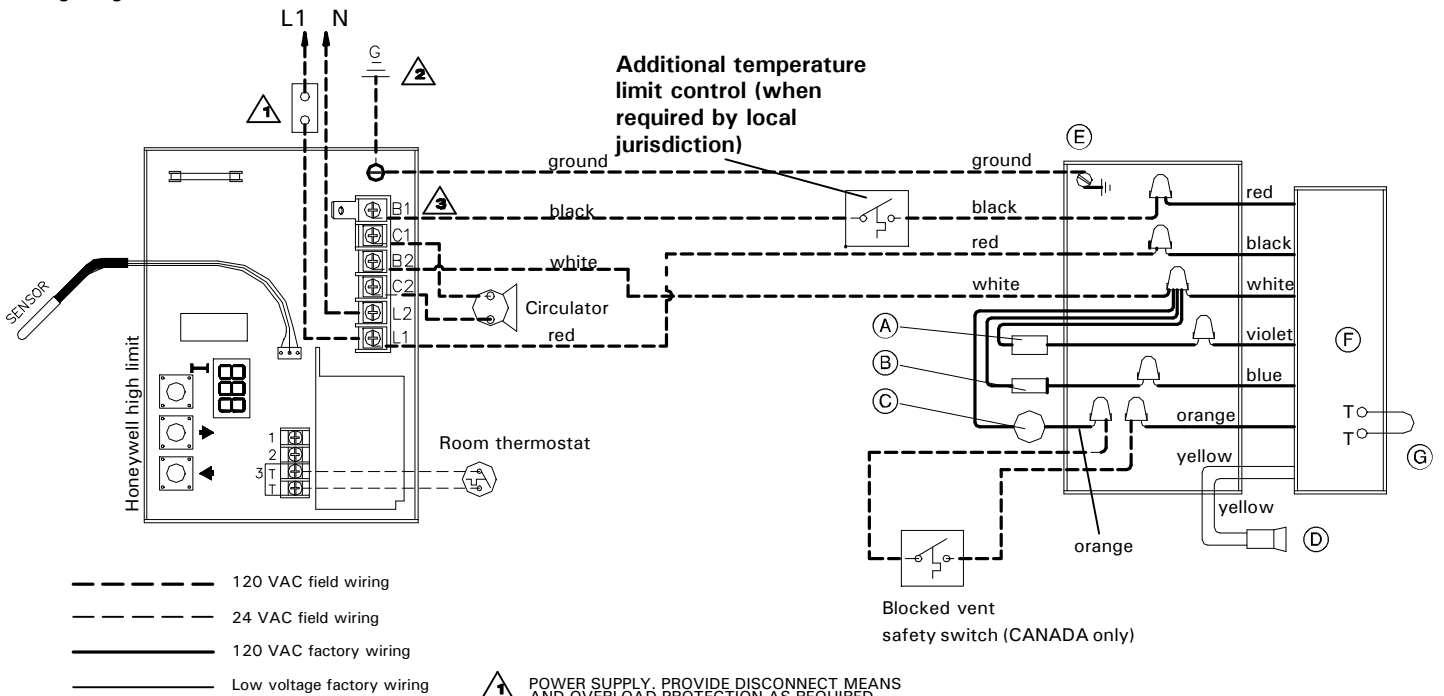

Fig. 25

Legend

- Ⓐ R7184 Series primary control with post-purge (factory default setting: 30 sec. - can be field adjusted; see Beckett burner manual)

- ⚠ 1 POWER SUPPLY. PROVIDE DISCONNECT MEANS AND OVERLOAD PROTECTION AS REQUIRED.
- ⚠ 2 CONTROL CASE MUST BE CONNECTED TO EARTH GROUND. USE GROUNDING SCREW PROVIDED.
- ⚠ 3 B1 IS 1/4 IN. TAB TERMINAL.

⚠ WARNING
Ensure that the burner cycles ON and OFF on proper call for heat before leaving the job site. Failure to do so may lead to boiler runaway situation, which may lead to property damage, personal injury or death.

IMPORTANT

If burner lock-out occurs, verify blocked vent safety switch operation first.

⚠ CAUTION
A field supplied manual reset high limit control must be installed at the outlet pipe of the boiler to interrupt burner operation should the factory supplied high limit control fail. This field supplied high limit control must be set 20°F above the setting of the factory supplied high limit control. The setting of this field supplied high limit control must never be greater than 220°F.

Burner Set-up (Beckett burner with GeniSys primary control) (continued)

Wiring diagram (Vitorond 100 with Beckett burner and Honeywell Aquastat) with outdoor reset module

! WARNING
 Electric shock hazard. Can cause severe personal injury or loss of life if power source, including service switch on boiler, is not disconnected before installing or servicing.

Installations must follow these codes and requirements:

- National Electrical Code, ANSI/NFPA 70, latest edition and any additional national, state or local codes.
- In Canada, CSA C22.1 Canadian Electrical Code Part 1 and any local codes.

- Wiring must be N.E.C. Class 1. If original wire as supplied with boiler must be replaced, type 105°C wire or equivalent must be used. Supply wiring to boiler and additional control wiring must be 14 ga. or heavier.
- Provide electrical ground at boiler as required by codes.

- ▶ All field supplied nominal 120 VAC voltage wiring must be sheathed in a flexible metal conduit.
- ▶ Disconnect means, overload protection and low water cut-off must be provided as required by local codes.
- ▶ Connect incoming line voltage HOT (L1) wire to terminal L1, and N to terminal L2 of the Honeywell high limit control (see wiring diagram below).

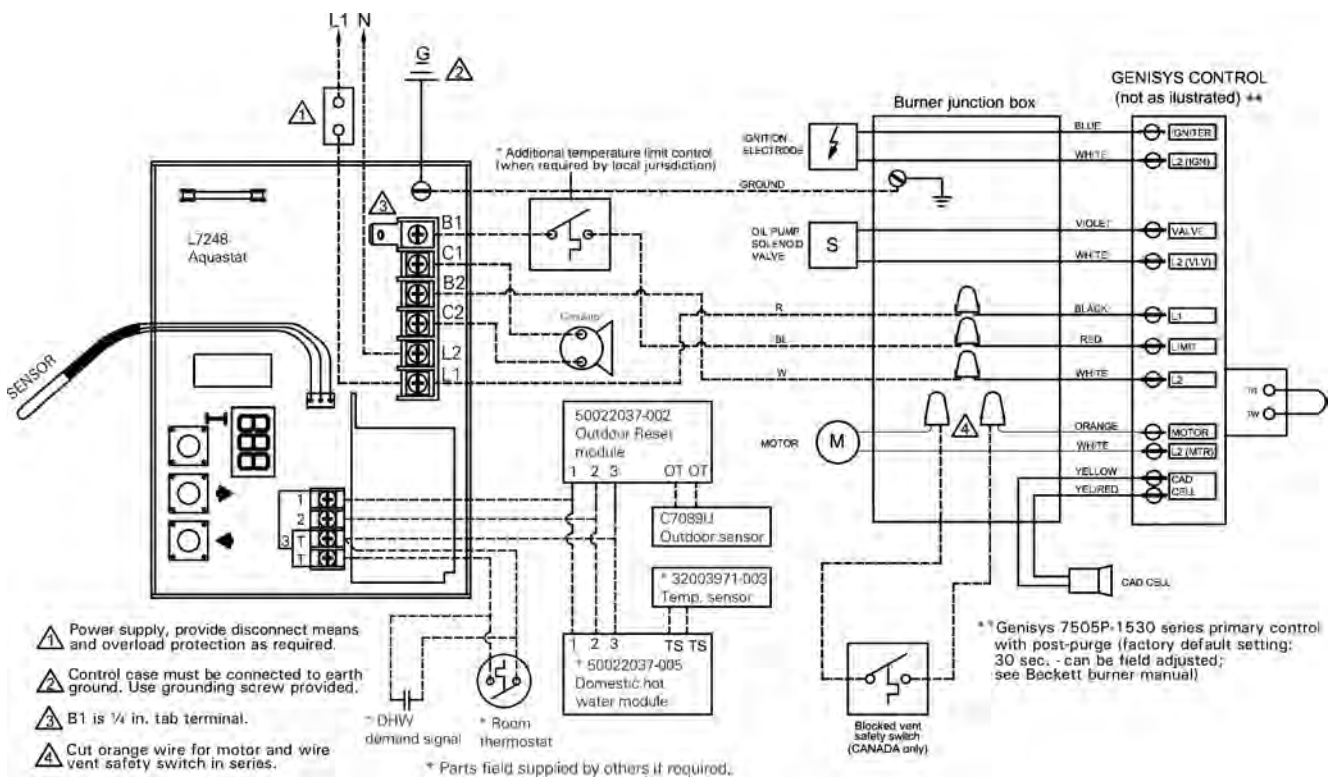

Fig. 26

! WARNING
 Ensure that the burner cycles ON and OFF on proper call for heat before leaving the job site. Failure to do so may lead to boiler runaway situation, which may lead to property damage, personal injury or death.

! CAUTION
 A field supplied manual reset high limit control must be installed at the outlet pipe of the boiler to interrupt burner operation should the factory supplied high limit control fail. This field supplied high limit control must be set 20°F above the setting of the factory supplied high limit control. The setting of this field supplied high limit control must never be greater than 220°F.

IMPORTANT
 If burner lock-out occurs, verify blocked vent safety switch operation first.

5671 043 v1.0

Burner Set-up (Beckett) *(continued)*

Electrical connections (with Vitotronic control)

! WARNING
 Electric shock hazard. Can cause severe personal injury or loss of life if power source, including service switch on boiler, is not disconnected before installing or servicing.

Installations must follow these codes and requirements:

- National Electrical Code, ANSI/NFPA 70, latest edition and any additional national, state or local codes.
- In Canada, CSA C22.1 Canadian Electrical Code Part 1 and any local codes.

- Wiring must be N.E.C. Class 1. If original wire as supplied with boiler must be replaced, type 105°C wire or equivalent must be used. Supply wiring to boiler and additional control wiring must be 14 ga. or heavier.
- Provide electrical ground at boiler as required by codes.

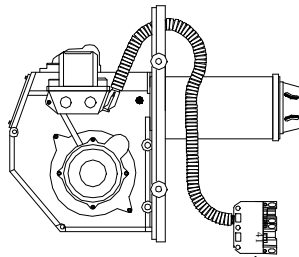

#41 plug-in connector

Burner wiring

IMPORTANT

The R7184 or GeniSys 7505P primary control with valve-on delay (pre-purge) and burner motor-off delay (post-purge - factory default settings can be field adjusted), requires a constant 120 VAC power source supplied to the **BLACK** wire on the control (see wiring diagram on page 38).

1. The cover mounting plate is not a conduit connection point. Pass conduit and attached connector through the front opening in the mounting plate or through one of the knockouts on either side of the cover and attach it directly to the burner-mounted 4x4 electrical junction box.

Electrical connections

1. Run the **41** plug-in connector cable of the Vitotronic control down behind the front panel of the boiler and out through the bottom. (Fig. 26)
2. Connect the female **41** plug of the burner to the male **41** plug of the Vitotronic control. (Fig. 26)

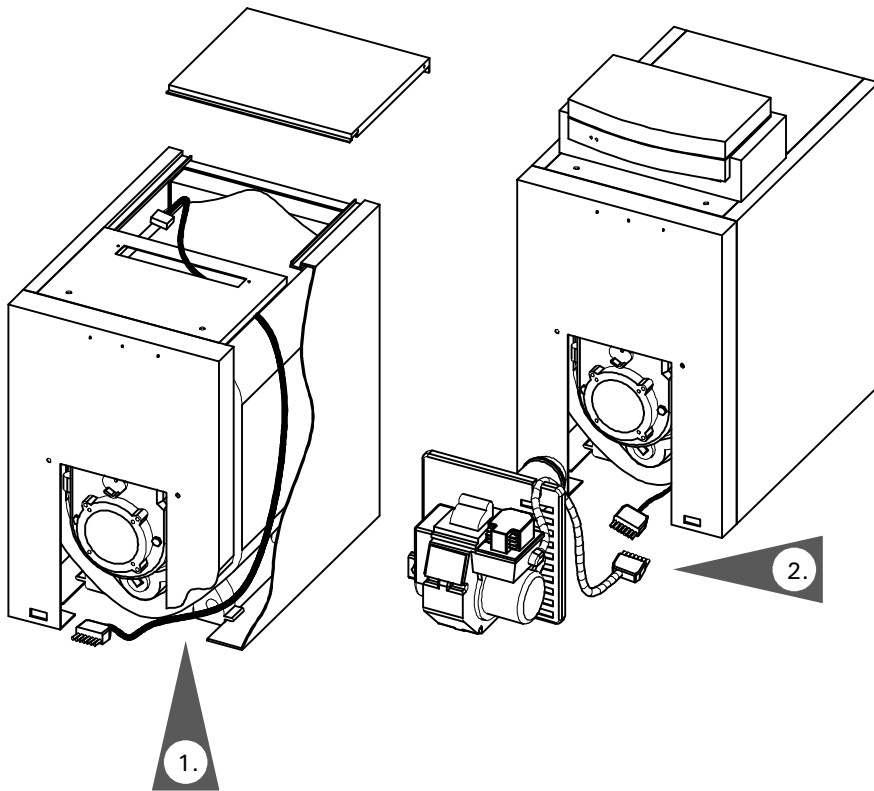

Fig. 27

Burner Set-up (Beckett) *(continued)*

Electrical connections (with Vitotronic control) *(continued)*

Room thermostat wiring

1. Install thermostat on inside wall away from influences of drafts, hot or cold water pipes, lighting fixtures, television, sun rays or fireplaces.
2. Follow instructions supplied with room thermostat. If it has a heat anticipator, set heat anticipator in thermostat to match power requirements of equipment connected to it. Boiler wiring diagrams give setting for standard equipment.

Installation of Vitotronic control

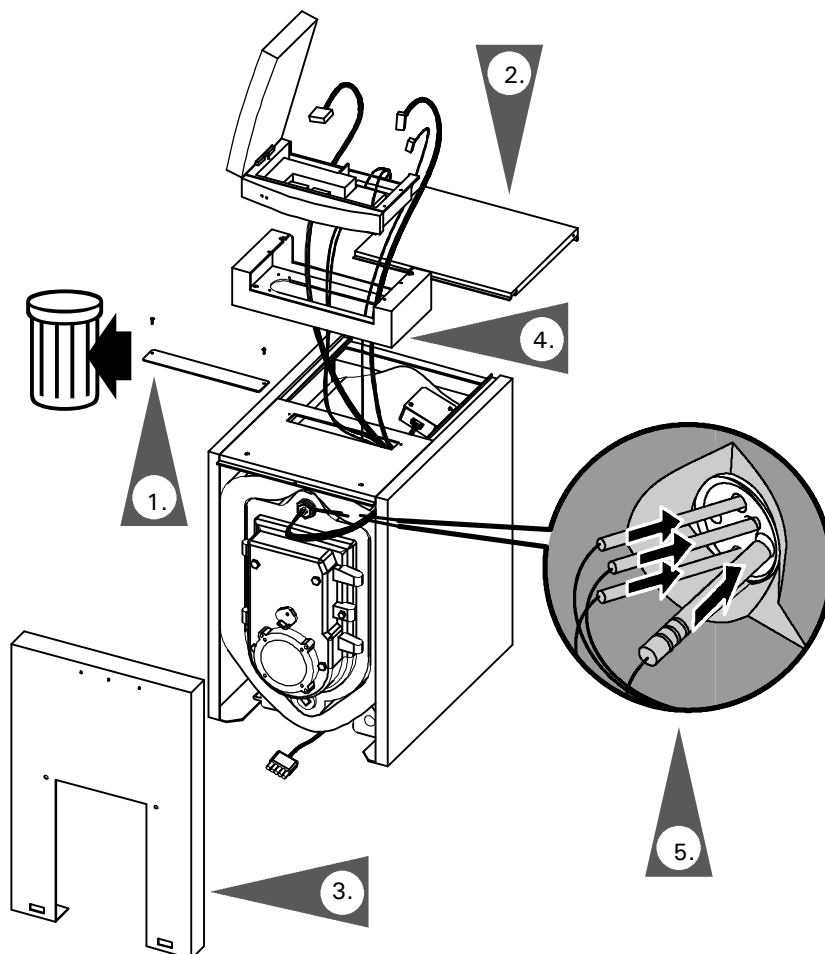

 *Installation Instructions
Boiler Control (for all
connections to control base)*

IMPORTANT

The power supply cable is shipped with the boiler control.

1. Loosen two screws and remove cover plate.
2. Remove top back panel.
3. Remove front panel.
4. Place control console on boiler and fasten with two screws removed in step 1.

WARNING

Do not kink capillaries. Proper operation of sensors is not possible if capillaries are kinked.

IMPORTANT

Boiler temperature sensor **3** is shipped with the boiler control (not applicable to Vitotronic 100, KK10).

5. Carefully push high limit and boiler temperature sensor **3** behind front panel and into sensor wells as far as possible. Lay excess sensor cabling and capillary tubing on insulation.

Burner Set-up (Beckett) *(continued)*

Installation of Vitotronic control *(continued)*

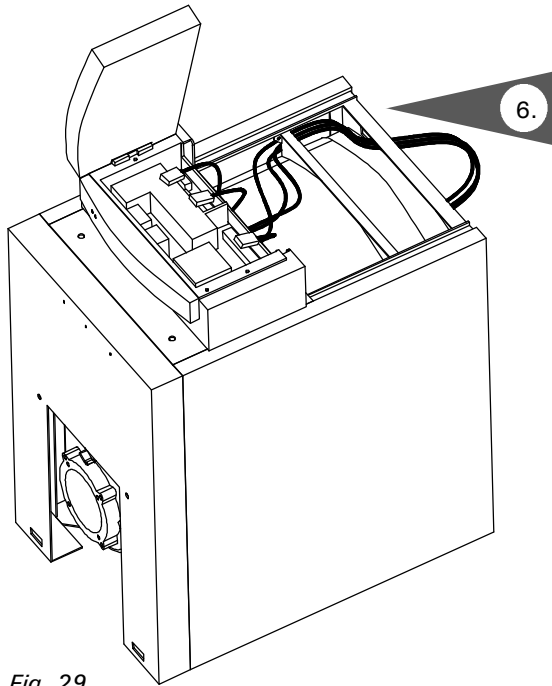

Fig. 29

6. Channel power supply cable or Power/Pump Module cable (for Vitotronic 200) and all other 120 VAC cabling through back opening toward boiler control.
7. Channel low voltage cables (i.e. sensor cables) through cable opening toward boiler control.
8. Coil excess cabling and tuck between side panel and insulation.



CAUTION

Always route all cables and capillaries between nylon backed insulation and metal enclosure panels, never directly on cast iron heat exchanger.

9. Tighten strain reliefs.

Burner Set-up (Beckett) *(continued)*

Installation of Vitotronic control *(continued)*

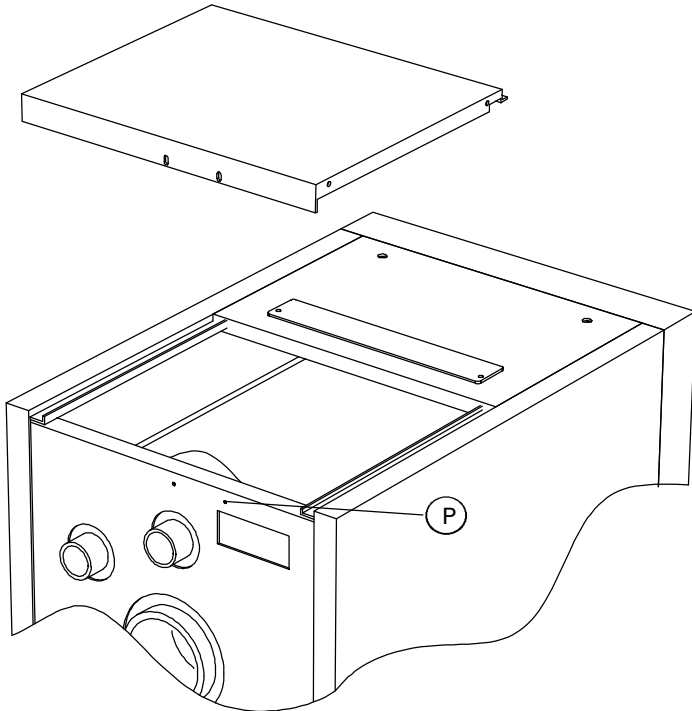
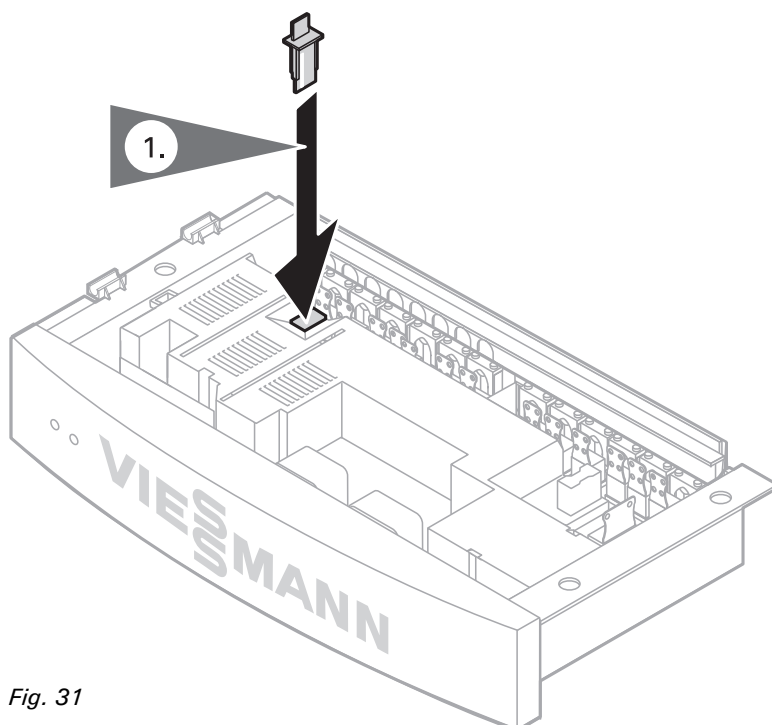

Fig. 30

1. To avoid problems with removing the top panel, we recommend moving the top panel screw approximately 3" to the left or right. To do this, pre-drill the panels with an 1/8" drill bit. To reinstall the top panel, drill a new 1/8" pilot hole through the top back panel and into the back panel. Reinstall the screw (P) into this new mounting hole.

Boiler coding card



IMPORTANT

Only the boiler coding card supplied with the standard equipment of the boiler may be used. The coding card is enclosed in the accessory pack of the boiler.

1. Push boiler coding card through recess in the cover and insert it into plug-in location "X7".

IMPORTANT

If the boiler coding card is not installed the following fault code will be displayed on the boiler control: "87".

Fig. 31

Burner Set-up (Beckett) *(continued)*

Electrical connections (with Vitotronic control)

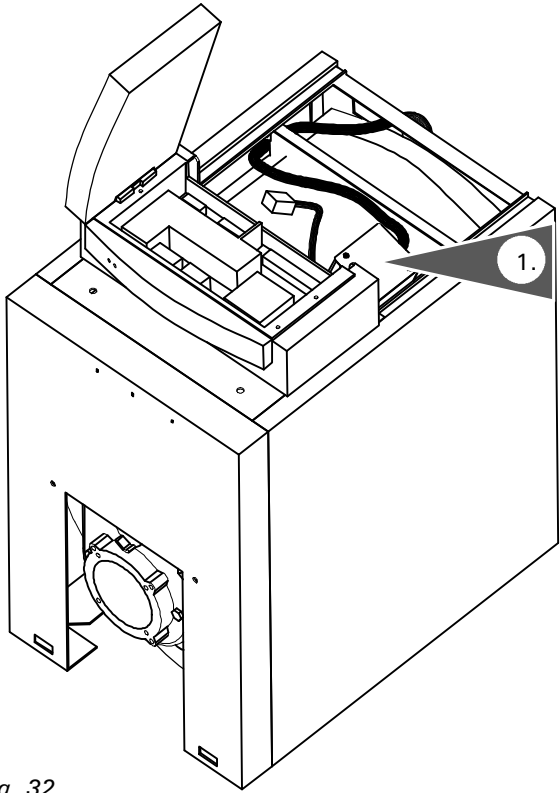

Fig. 32
Installation location of pump junction box

The pump junction box supplies power to field supplied pumps. It is shipped with the boiler and must be installed whenever each of the boilers is installed in conjunction with the following controls:

- Vitotronic 100, KK10
- Vitotronic 100, KW10

If installing Vitotronic 200 or Vitotronic 100- KW10A / KW10B, discard the pump junction box.

1. Place pump junction box underneath top panel near the back of the boiler, as shown in Fig. 31.
2. Connect the RAST-5 plug-in connector 20 of the Pump Junction Box to the main circuit board of the control, as shown in Fig. 31.
3. Feed the power supply cabling of the system pump through the opening at the back of the boiler and connect to terminals in pump junction box. (See Fig. 32).

IMPORTANT

Run BX (armoured cable) or any other approved wire (required by local authority having jurisdiction) from junction box terminal to heating circuit pump.

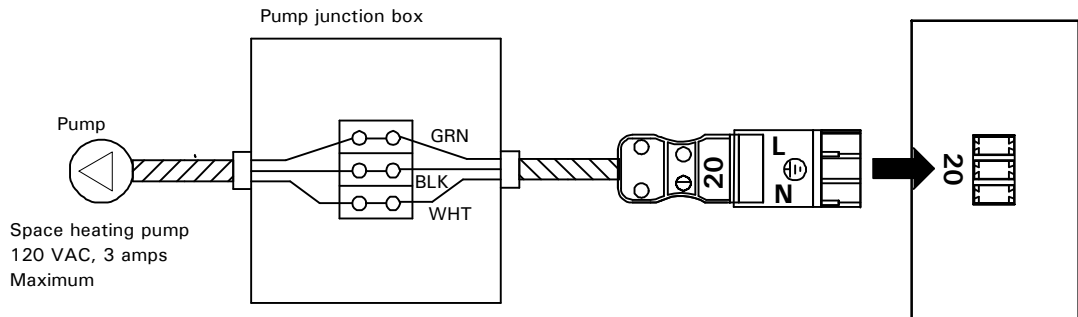
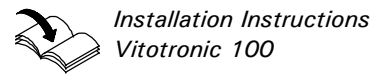

Fig. 33
Pump junction box

Burner Set-up (Beckett) (continued)

Electrical connections (with Vitotronic control) (continued)

! WARNING

Electric shock hazard. Can cause severe personal injury or loss of life if power source, including service switch on boiler, is not disconnected before installing or servicing.

Installations must follow these codes and requirements:

- National Electrical Code, ANSI/NFPA 70, latest edition and any additional national, state or local codes.
- In Canada, CSA C22.1 Canadian Electrical Code Part 1 and any local codes.

- Wiring must be N.E.C. Class 1. If original wire as supplied with boiler must be replaced, type 105°C wire or equivalent must be used. Supply wiring to boiler and additional control wiring must be 14 ga. or heavier.
- Provide electrical ground at boiler as required by codes.

Burner wiring harness (supplied)

Closed end connectors are factory installed on RED, ORANGE and BLUE wires. These RED, ORANGE and BLUE wires may or may not be used in your burner application. See wiring diagram in this manual which is specific to your burner application. Do not remove or cut any of the closed end connectors of the RED, ORANGE or BLUE wires, unless it is necessary to do so. RED wire is live (120VAC) at all times. Do not remove or cut its closed end connector unless it is necessary to do so. Failure to heed the above instructions may cause severe personal injury or loss of life.

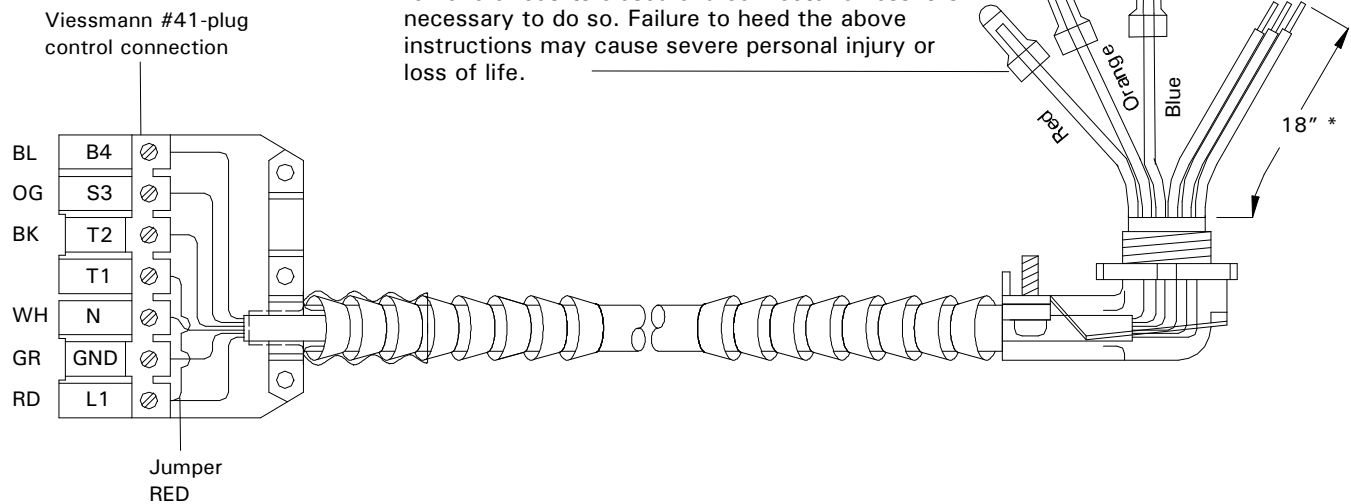

Fig. 34

Legend

BL	Blue
OR	Orange
BK	Black
WH	White
GR	Green
RD	Red

* If Beckett burner is being installed, cut this length to 6" for connection to burner junction box (located under the burner primary control).

Burner Set-up (Beckett) *(continued)*

Wiring diagram (with Vitotronic control)

⚠ WARNING
Electric shock hazard. Can cause severe personal injury or loss of life if power source, including service switch on boiler, is not disconnected before installing or servicing.

Installations must follow these codes and requirements:

- National Electrical Code, ANSI/NFPA 70, latest edition and any additional national, state or local codes.
- In Canada, CSA C22.1 Canadian Electrical Code Part 1 and any local codes.

- Wiring must be N.E.C. Class 1. If original wire as supplied with boiler must be replaced, type 105°C wire or equivalent must be used. Supply wiring to boiler and additional control wiring must be 14 ga. or heavier.
- Provide electrical ground at boiler as required by codes.

Blue and orange wires not used in this application, DO NOT cut or remove closed end connector from the wires.

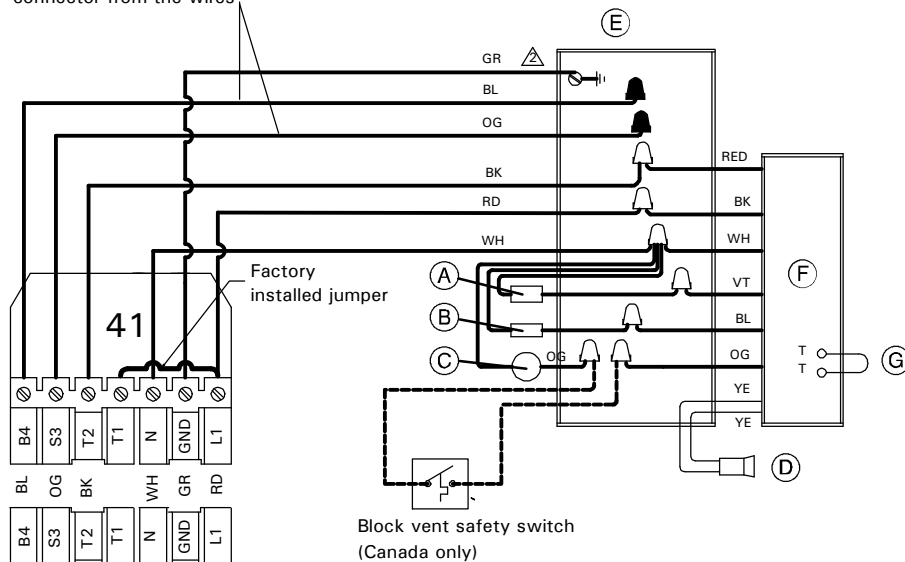

⚠ WARNING
Ensure that the burner cycles ON and OFF on proper call for heat before leaving the job site. Failure to do so may lead to boiler runaway situation, which may lead to property damage, personal injury or death.

IMPORTANT

If burner lock-out occurs, verify blocked vent safety switch operation first.

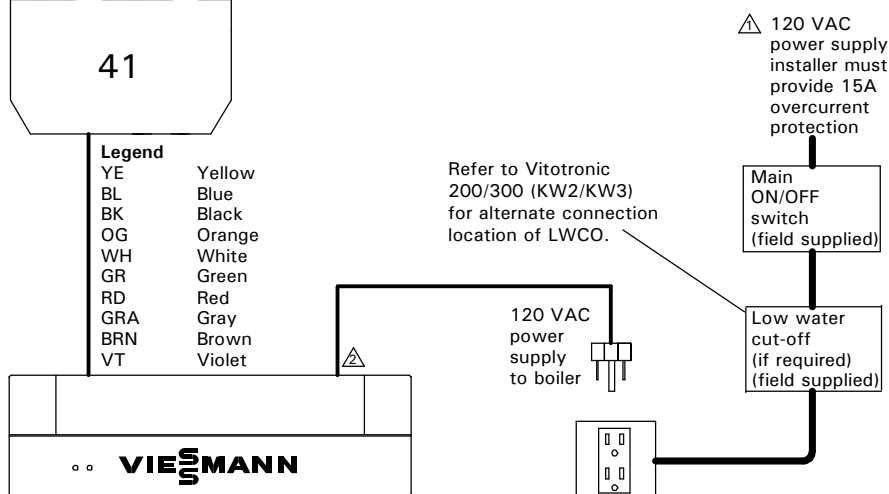

Legend

YE	Yellow
BL	Blue
BK	Black
OG	Orange
WH	White
GR	Green
RD	Red
GRA	Gray
BRN	Brown
VT	Violet

- Legend**
- (A) Oil solenoid valve
 - (B) Ignition transformer
 - (C) Burner motor
 - (D) CAD cell flame detector
 - (E) Burner grounding screw
 - (F) R7184 Series primary control with post-purge (factory default setting: 30 sec. - can be field adjusted; see Beckett burner manual)
 - (G) Factory-installed jumper

Vitotronic Control
 (Refer to corresponding Vitotronic Control manual)

- ⚠ Power supply. Provide disconnect means and overload protection as required.
- ⚠ Control case must be connected to earth ground.

Fig. 35

Burner Set-up (Beckett burner with GeniSys primary control) (continued)

Wiring diagram (Vitorond 100 with Beckett burner, GeniSys control and Vitotronic control)

! WARNING
Electric shock hazard. Can cause severe personal injury or loss of life if power source, including service switch on boiler, is not disconnected before installing or servicing.

- Installations must follow these codes and requirements:*
- National Electrical Code, ANSI/NFPA 70, latest edition and any additional national, state or local codes.
 - In Canada, CSA C22.1 Canadian Electrical Code Part 1 and any local codes.

- Wiring must be N.E.C. Class 1. If original wire as supplied with boiler must be replaced, type 105°C wire or equivalent must be used. Supply wiring to boiler and additional control wiring must be 14 ga. or heavier.
- Provide electrical ground at boiler as required by codes.

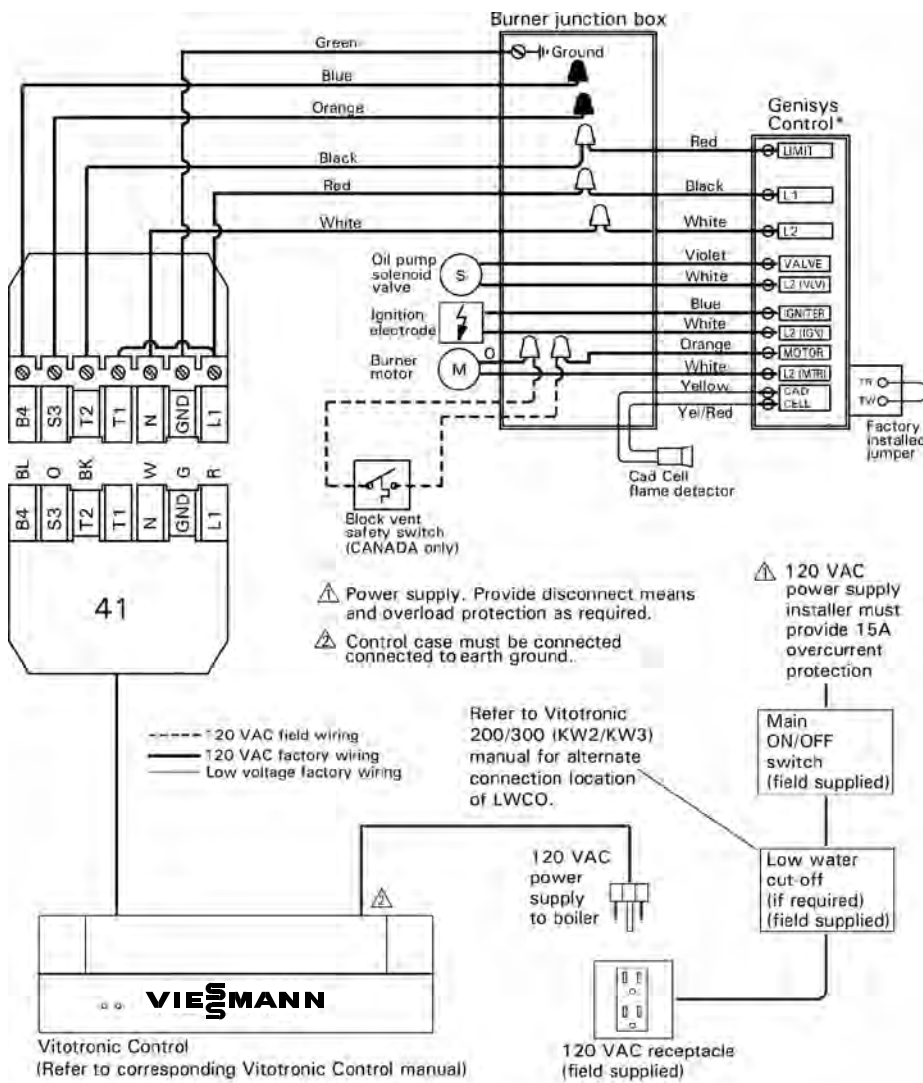

! WARNING
Ensure that the burner cycles ON and OFF on proper call for heat before leaving the job site. Failure to do so may lead to boiler runaway situation, which may lead to property damage, personal injury or death.

IMPORTANT

If burner lock-out occurs, verify blocked vent safety switch operation first.

* Genisys 7505P-1530 series primary control with post-purge (factory default setting: 30 sec. - can be field adjusted; see Beckett burner manual).

Fig. 36

Burner Installation (Riello)



*Instructions supplied
with Riello burner*

Observe all instructions supplied with the burner.

Burner Information

Fuel

This boiler is for use with the Riello #2 fuel oil burner supplied by Viessmann only. Use only the fuel stated on the rating plate of the burner.

Oil nozzle

The Riello burner for the VR1-22 and -33 boiler is shipped with factory setting and oil nozzle installed, and should require only minor adjustments. For VR1-27 boiler, replace installed nozzle with nozzle packaged with burner.

For Riello burner specifications see table on page 56.

Burner calibration

Ensure that the combustion results of the oil-fired burner mounted on this boiler are verified after start-up.

If adjustments are necessary, always verify results with a calibrated flue gas analyzer.

For Riello burner specifications see table on page 56.



WARNING

**DO NOT USE GASOLINE
CRANKCASE DRAININGS OR ANY
OIL CONTAINING GASOLINE.**

IMPORTANT

This burner is shipped with the oil pump set to operate on a single line system. To operate on a two-line system, the bypass plug must be installed. The burner is shipped configured for use in single line applications. No changes to the oil pump are required for use in single line applications.

Burner Set-up (Riello)

Burner mounting

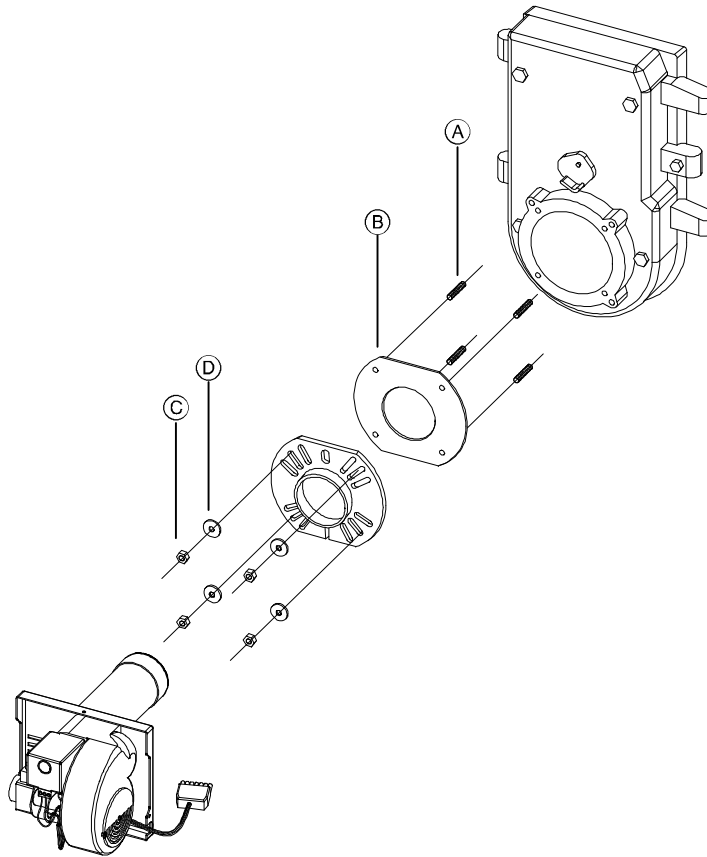

Fig. 37
Burner mounting



*Instructions supplied with
Riello burner.*

1. Remove burner from carton. The mounting flange has been installed at the factory.
2. Mount four M8 spacer bolts (A) in threaded holes of combustion chamber door.
3. Slide burner gasket (B) over spacer bolts.
4. Mount burner as shown.
(For proper insertion lengths see table on page 56).
5. Secure burner with M8 nuts (C) and washers (D) provided.

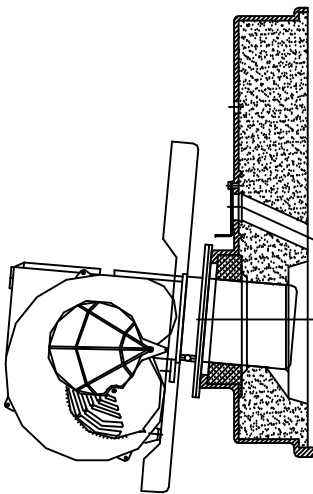



Fig. 38
Burner air tube insertion,

Burner Set-up (Riello) *(continued)*

Oil piping

 *Riello burner instructions*

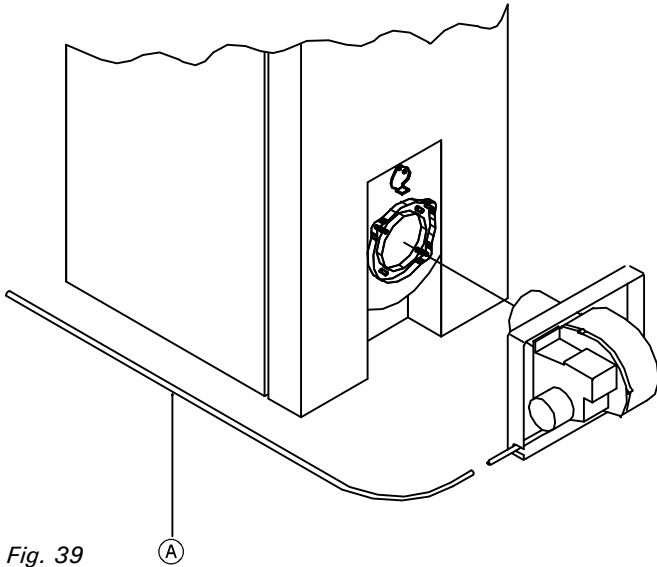

Fig. 39

Legend

Ⓐ Oil line (see local codes for appropriate arrangement and piping of filter control valves, etc., back to oil tank)

IMPORTANT

This burner is shipped with the oil pump set to operate on a single line system. To operate on a two-line system, the bypass plug must be installed. The burner is shipped configured for use in single line applications. No changes to the oil pump are required for use in single line applications.

General oil piping requirements

- Location and installation of oil tanks, oil piping and burners must follow:
- Local codes and regulations.
 - Information provided with burner and fuel pump.
 - In Canada, CSA B139, Installation of Oil-Burning Equipment.
 - In USA, NFPA 31, Standard for the Installation of Oil-Burning Equipment.

⚠ WARNING
 Do not use Teflon tape as an oil pipe sealant. It can cause valves to fail, creating hazards. Do not use compression fittings.

Underground oil line piping must be encased to prevent oil leaking into ground. Check local codes for information.

If any part of fuel oil tank is above burner level, an anti-siphon device must be used to prevent flow of oil in case of oil line break.

Make tank connections with swing joints or copper tubing to prevent breaking in case the tank settles. Make swing joints so they will tighten as tank settles. Non-hardening pipe joint compounds should be used on all threads. Do not use pipe dope or Teflon tape.

Support oil lines as required by codes.

Oil piping connection at burner

See illustration Fig. 37 for recommended connection at burner, allowing burner mounting door to swing open completely for servicing.

⚠ WARNING
 The oil supply inlet pressure to the fuel unit cannot exceed 3 psig. Install a pressure-limiting device in accordance with the above mentioned codes.

5671 043 v1.0

Burner Set-up (Riello)

Electrical connections (with Aquastat control)

! WARNING
Electric shock hazard. Can cause severe personal injury or loss of life if power source, including service switch on boiler, is not disconnected before installing or servicing.

Installations must follow these codes and requirements:

- National Electrical Code, ANSI/NFPA 70, latest edition and any additional national, state or local codes.
- In Canada, CSA C22.1 Canadian Electrical Code Part 1 and any local codes.

- Wiring must be N.E.C. Class 1. If original wire as supplied with boiler must be replaced, type 105°C wire or equivalent must be used. Supply wiring to boiler and additional control wiring must be 14 ga. or heavier.
- Provide electrical ground at boiler as required by codes.

- ▶ All field supplied nominal 120 VAC voltage wiring must be sheathed in a flexible metal conduit.
- ▶ Disconnect means, overload protection and low water cut-off must be provided as required by local codes.
- ▶ Connect incoming line voltage HOT (L1) wire to terminal L1, and N to terminal L2 of the Honeywell high limit control (see wiring diagram on page 44).

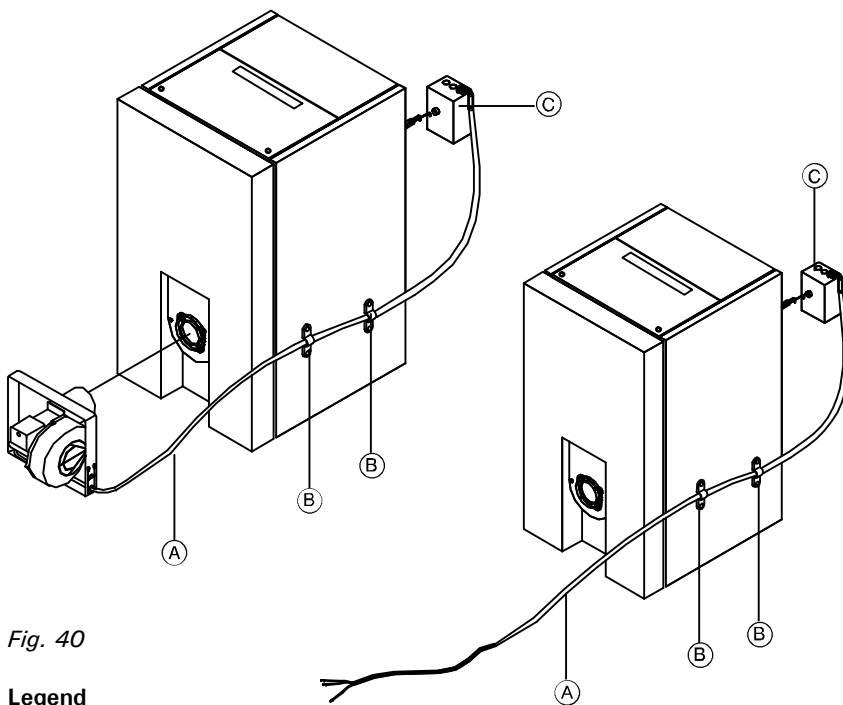

Fig. 40

Legend

- (A) Burner and control harness, (see wiring diagram on pages 44 and 44)
- (B) Cable strap (supplied)
- (C) Honeywell high limit control

Burner wiring

1. Secure control harness (A) using 2 supplied cable straps (B).

! WARNING
Ensure that burner wiring harness is properly attached and secured to the boiler side panel using the supplied cable straps as depicted above. The cable strap must be coiled on the boiler side panel so that no slack is left, allowing the burner/boiler door to be swung open without disconnecting the burner wiring harness from the burner. Failure to heed this warning may result in personal injury.

Room thermostat wiring

1. Install thermostat on inside wall away from influences of drafts, hot or cold water pipes, lighting fixtures, television, sun rays or fireplaces.
2. Follow instructions supplied with room thermostat. If it has a heat anticipator, set heat anticipator in thermostat to match power requirements of equipment connected to it. Boiler wiring diagrams give setting for standard equipment.

Burner Set-up (Riello) *(continued)*

Wiring harness connection to Honeywell high limit and Riello burner subbase (with Aquastat control)

⚠ WARNING
Electric shock hazard. Can cause severe personal injury or loss of life if power source, including service switch on boiler, is not disconnected before installing or servicing.

Installations must follow these codes and requirements:

- National Electrical Code, ANSI/NFPA 70, latest edition and any additional national, state or local codes.
- In Canada, CSA C22.1 Canadian Electrical Code Part 1 and any local codes.

- Wiring must be N.E.C. Class 1. If original wire as supplied with boiler must be replaced, type 105°C wire or equivalent must be used. Supply wiring to boiler and additional control wiring must be 14 ga. or heavier.
- Provide electrical ground at boiler as required by codes.

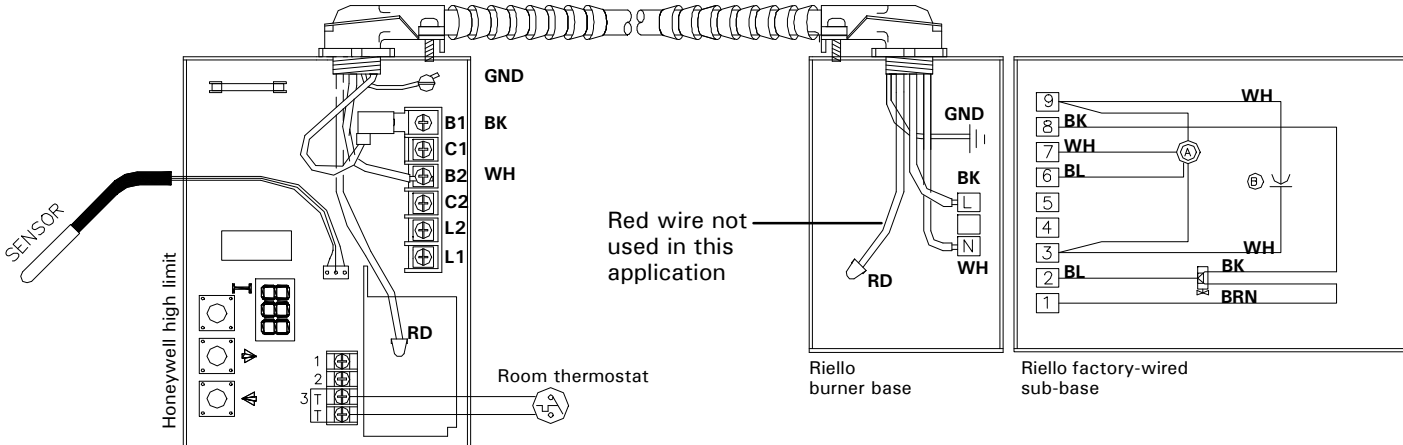

Fig. 41

Legend

- (A) Burner motor
- (B) Capacitor

- RD Red
- BK Black
- BL Blue
- BRN Brown
- GND Ground
- WH White

IMPORTANT

Red wire not used in this application. Use wire nuts to cap both ends (inside high limit control and Riello burner sub-base)

Burner Set-up (Riello) (continued)

Wiring diagram (with Aquastat control) with outdoor reset module

! WARNING
Electric shock hazard. Can cause severe personal injury or loss of life if power source, including service switch on boiler, is not disconnected before installing or servicing.

Installations must follow these codes and requirements:

- National Electrical Code, ANSI/NFPA 70, latest edition and any additional national, state or local codes.
- In Canada, CSA C22.1 Canadian Electrical Code Part 1 and any local codes.

- Wiring must be N.E.C. Class 1. If original wire as supplied with boiler must be replaced, type 105°C wire or equivalent must be used. Supply wiring to boiler and additional control wiring must be 14 ga. or heavier.
- Provide electrical ground at boiler as required by codes.

- ▶ All field supplied nominal 120 VAC voltage wiring must be sheathed in a flexible metal conduit.
- ▶ Disconnect means, overload protection and low water cut-off must be provided as required by local codes.
- ▶ Connect incoming line voltage HOT (L1) wire to terminal L1, and N to terminal L2 of the Honeywell high limit control (see wiring diagram below).

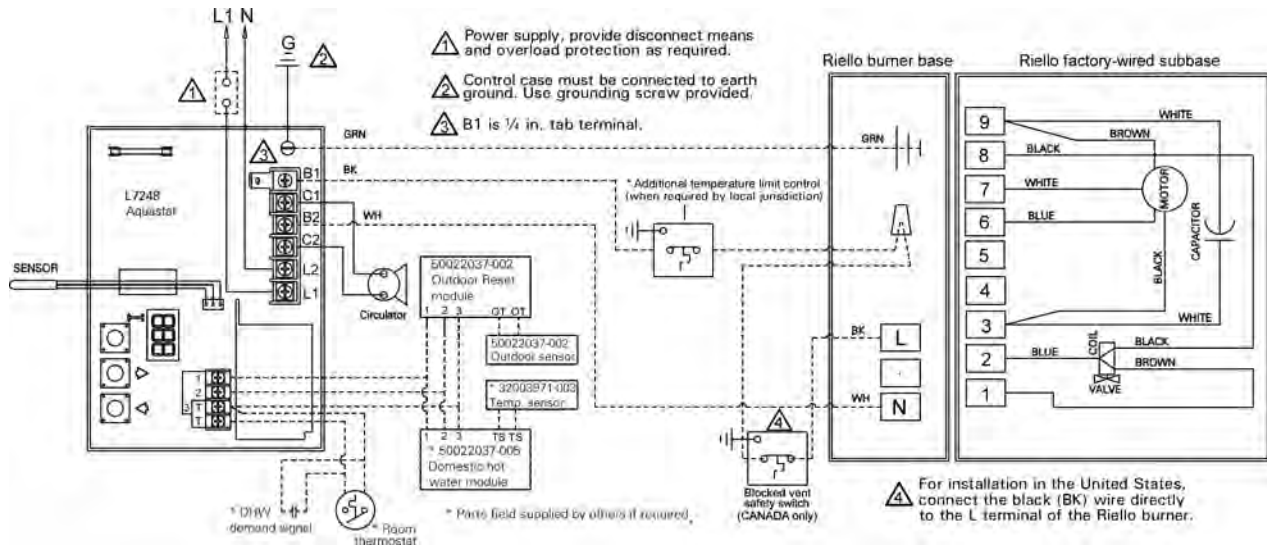

Fig. 42

IMPORTANT

Red wire not used in this application. Use wire nuts to cap both ends (inside high limit control and Riello burner sub-base).

! WARNING
Ensure that the burner cycles ON and OFF on proper call for heat before leaving the job site. Failure to do so may lead to boiler runaway situation, which may lead to property damage, personal injury or death.

! CAUTION
A field supplied manual reset high limit control must be installed at the outlet pipe of the boiler to interrupt burner operation should the factory supplied high limit control fail. This field supplied high limit control must be set 20°F above the setting of the factory supplied high limit control. The setting of this field supplied high limit control must never be greater than 220°F.

Burner Set-up (Riello)

Installation of Vitotronic control

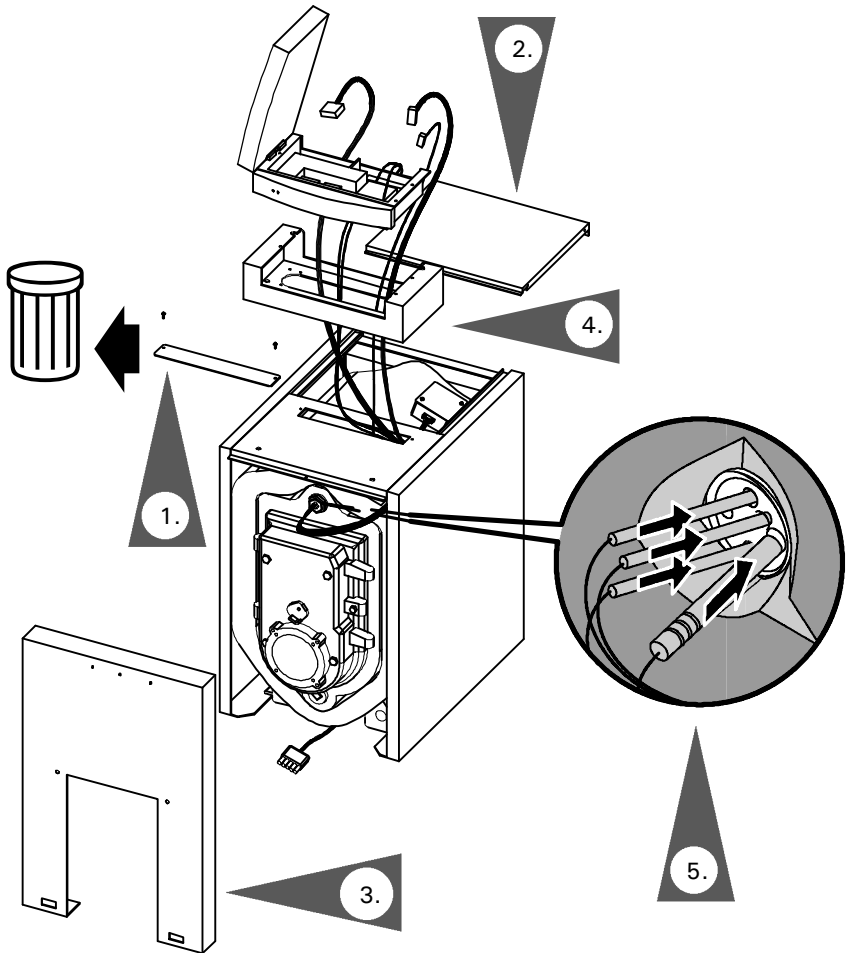



Fig. 43

 *Installation Instructions
Boiler Control (for all
connections to control base)*

IMPORTANT

The power supply cable is shipped with the boiler control.

1. Loosen two screws and remove cover plate.
2. Remove top back panel.
3. Remove front panel.
4. Place control console on boiler and fasten with two screws removed in step 1.

 **WARNING**
Do not kink capillaries. Proper operation of sensors is not possible if capillaries are kinked.

IMPORTANT

Boiler temperature sensor number **3** is shipped with the boiler control (does not apply to Vitotronic 100, KK10).

5. Carefully push high limits thermometer sensor and boiler temperature sensor **3** behind front panel and into sensor wells as far as possible. Lay excess sensor cabling and capillary tubing on insulation.

Burner Set-up (Riello) *(continued)***Installation of Vitotronic control** *(continued)*

Fig. 44

6. Channel power supply cable or Power/Pump Module cable (for Vitotronic 200) and all other 120 VAC cabling through back opening toward boiler control.
7. Channel low voltage cables (i.e. sensor cables) through cable opening toward boiler control.
8. Coil excess cabling and tuck between side panel and insulation.

⚠ WARNING

Always route all cables and capillaries between nylon backed insulation and metal enclosure panels, never directly on cast iron heat exchanger.

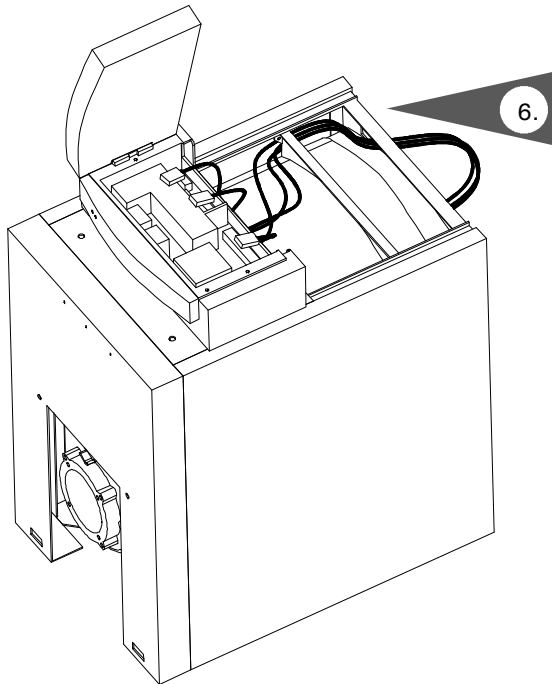
Burner Set-up (Riello) (Vitotronic Control)

Electrical connections (with Vitotronic control)

! WARNING
 Electric shock hazard. Can cause severe personal injury or loss of life if power source, including service switch on boiler, is not disconnected before installing or servicing.

Installations must follow these codes and requirements:

- National Electrical Code, ANSI/NFPA 70, latest edition and any additional national, state or local codes.
- In Canada, CSA C22.1 Canadian Electrical Code Part 1 and any local codes.

- Wiring must be N.E.C. Class 1. If original wire as supplied with boiler must be replaced, type 105°C wire or equivalent must be used. Supply wiring to boiler and additional control wiring must be 14 ga. or heavier.
- Provide electrical ground at boiler as required by codes.

Room thermostat wiring

1. Install thermostat on inside wall away from influences of drafts, hot or cold water pipes, lighting fixtures, television, sun rays or fireplaces.
2. Follow instructions supplied with room thermostat. If it has a heat anticipator, set heat anticipator in thermostat to match power requirements of equipment connected to it. Boiler wiring diagrams give setting for standard equipment.

Electrical connections

1. Run the #41 plug-in connector cable of the Vitotronic control down behind the front panel of the boiler and out through the bottom. (Fig. 43)
2. Connect the female #41 plug of the burner to the male #41 plug of the Vitotronic control. (Fig. 43)

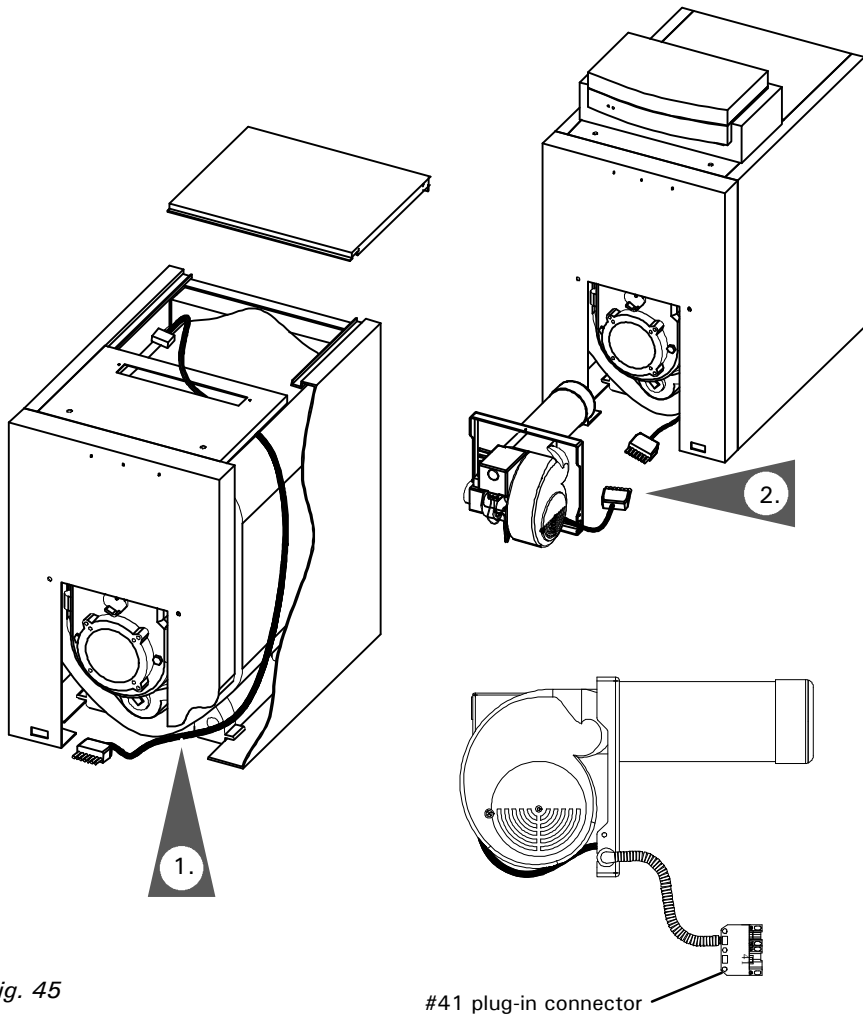

Fig. 45

Burner Set-up (Riello) (continued)

Electrical connections (with Vitotronic control)

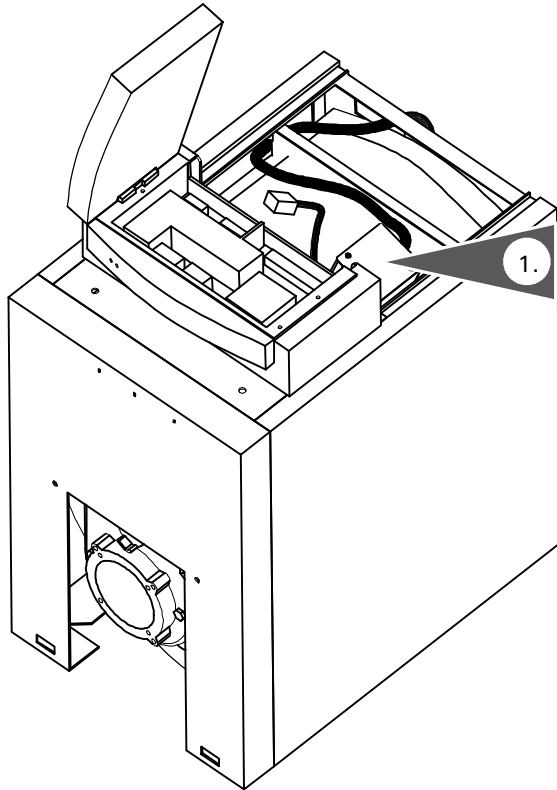

Fig. 46
Installation location of pump junction box

The pump junction box supplies power to field supplied pumps. It is shipped with the boiler and must be installed whenever each of the boilers is installed in conjunction with the following controls:

- Vitotronic 100, KK10
- Vitotronic 100, KW10

If installing Vitotronic 200 or Vitotronic 100- KW10A / KW10B, discard the pump junction box.

Installation instructions

Install the pump junction box as follows:

1. Pump junction box must be placed underneath top panel near the back of the boiler, as shown in Fig. 44.
2. Connect the RAST-5 plug-in connector 20 of the Pump Junction Box to the main circuit board of the control, as shown in Fig. 45.
3. Feed the power supply cabling of the system pump through the opening at the back of the boiler and connect to terminals in pump junction box (See Fig. 45).

IMPORTANT

Run BX (armoured cable) or any other approved wire (required by local authority having jurisdiction) from junction box terminal to heating circuit pump.

 *Installation Instructions
Vitotronic 100*

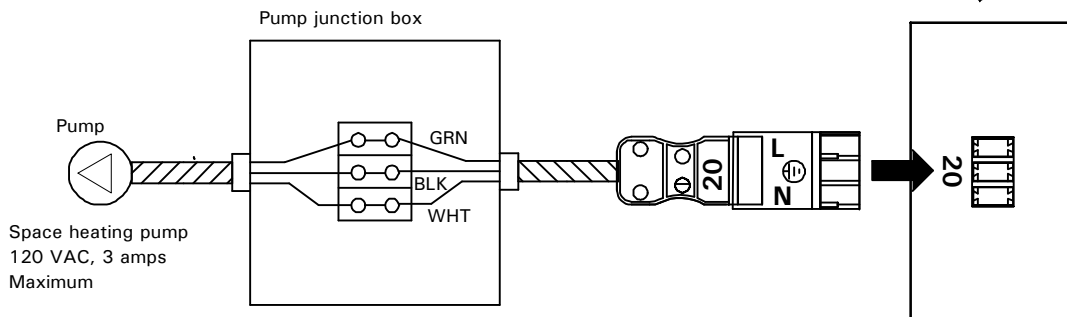

Fig. 47
Pump junction box

Burner Set-up (Riello) *(continued)*

Electrical connections (with Vitotronic control) *(continued)*

⚠ WARNING
Electric shock hazard. Can cause severe personal injury or loss of life if power source, including service switch on boiler, is not disconnected before installing or servicing.

Installations must follow these codes and requirements:

- National Electrical Code, ANSI/NFPA 70, latest edition and any additional national, state or local codes.
- In Canada, CSA C22.1 Canadian Electrical Code Part 1 and any local codes.

- Wiring must be N.E.C. Class 1. If original wire as supplied with boiler must be replaced, type 105°C wire or equivalent must be used. Supply wiring to boiler and additional control wiring must be 14 ga. or heavier.
- Provide electrical ground at boiler as required by codes.

Burner wiring harness (supplied)

Closed end connectors are factory installed on RED, ORANGE and BLUE wires. These RED, ORANGE and BLUE wires may or may not be used in your burner application. See wiring diagram in this manual which is specific to your burner application. Do not remove or cut any of the closed end connectors of the RED, ORANGE or BLUE wires, unless it is necessary to do so. RED wire is live (120VAC) at all times. Do not remove or cut its closed end connector unless it is necessary to do so. Failure to heed the above instructions may cause severe personal injury or loss of life.

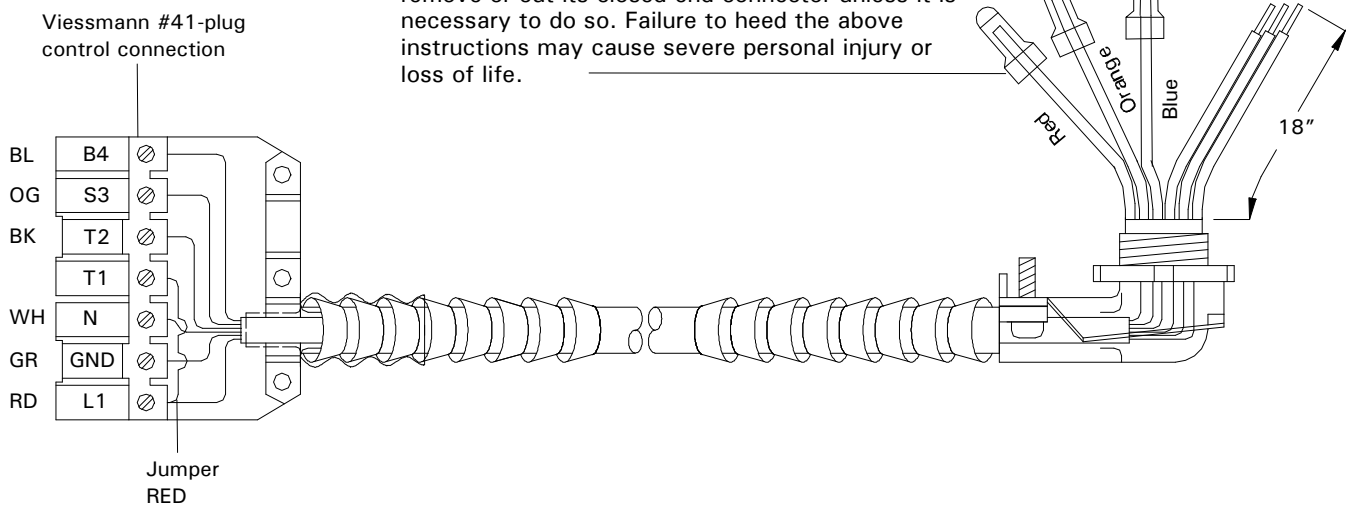

Fig. 48

Legend

BL	Blue
OG	Orange
BK	Black
WH	White
GR	Green
RD	Red

Burner Set-up (Riello) *(continued)*

Wiring diagram (with Vitotronic control) *(continued)*

WARNING
 Electric shock hazard. Can cause severe personal injury or loss of life if power source, including service switch on boiler, is not disconnected before installing or servicing.

WARNING
 RED wire not used in this application. DO NOT cut or remove closed end connector from the wire. (Live 120VAC at all times).

Installations must follow these codes and requirements:

- National Electrical Code, ANSI/NFPA 70, latest edition and any additional national, state or local codes.
- In Canada, CSA C22.1 Canadian Electrical Code Part 1 and any local codes.

- Wiring must be N.E.C. Class 1. If original wire as supplied with boiler must be replaced, type 105°C wire or equivalent must be used. Supply wiring to boiler and additional control wiring must be 14 ga. or heavier.
- Provide electrical ground at boiler as required by codes.

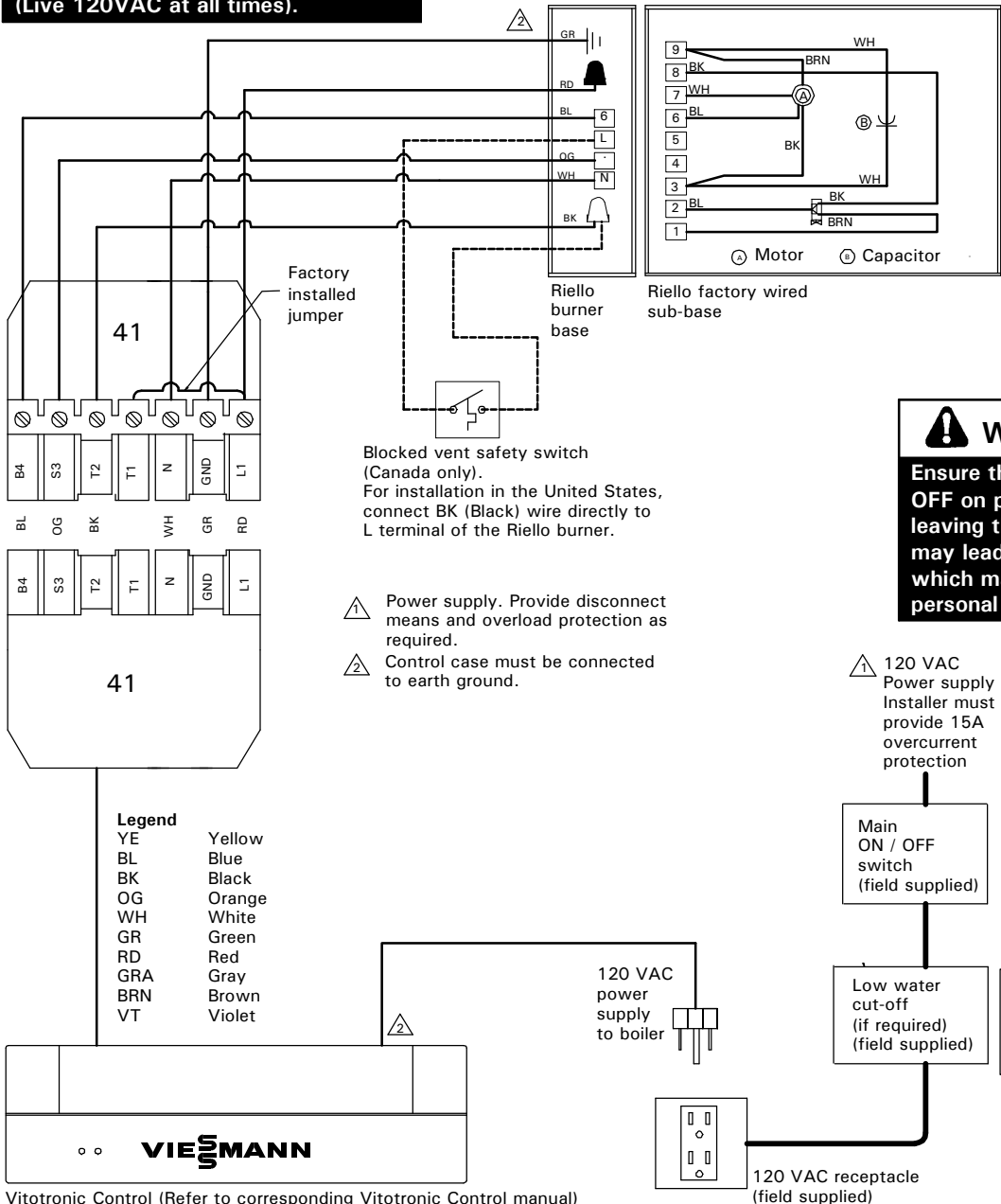

WARNING
 Ensure that the burner cycles ON and OFF on proper call for heat before leaving the job site. Failure to do so may lead to boiler runaway situation, which may lead to property damage, personal injury or death.

- ⚠ Power supply. Provide disconnect means and overload protection as required.
- ⚠ Control case must be connected to earth ground.

⚠ 120 VAC Power supply
 Installer must provide 15A overcurrent protection

Refer to Vitotronic 200 / 300 (KW2 / KW3) manual for alternate connection location of LWCO.

5671 043 v1.0

Vitotronic Control (Refer to corresponding Vitotronic Control manual)
 Fig. 49

Burner Set-up (Riello) (continued)

Installation of Vitotronic control (continued)

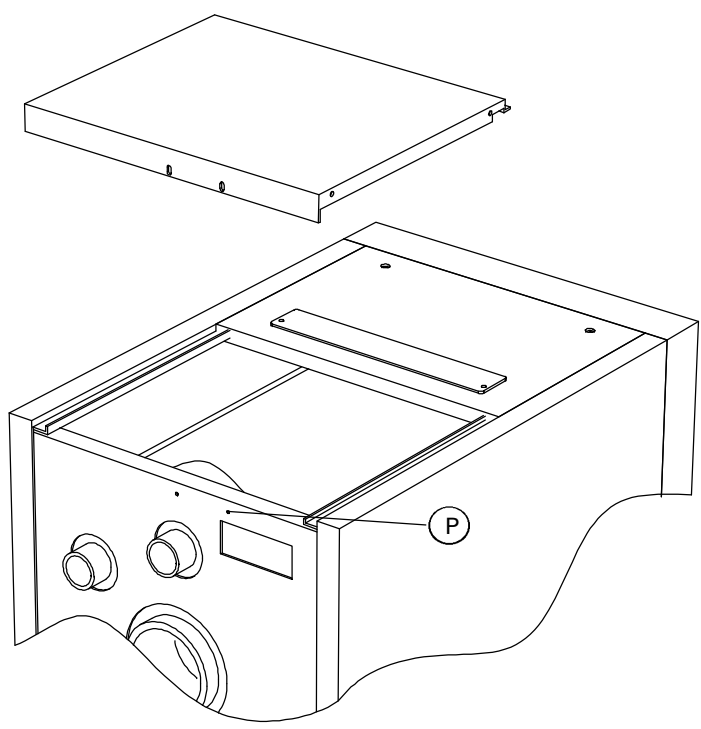

Fig. 50

1. To avoid problems with removing the top panel, we recommend moving the top panel screw approximately 3" to the left or right. To do this, pre-drill the panels with an 1/8" drill bit. To reinstall the top panel, drill a new 1/8" pilot hole through the top back panel and into the back panel. Reinstall the screw (P) into this new mounting hole.

Boiler coding card

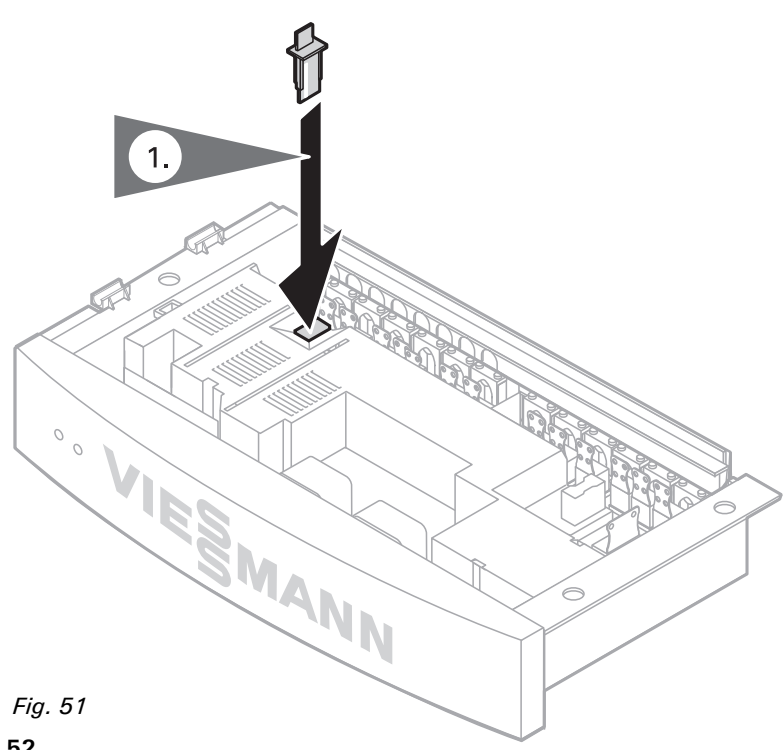

Fig. 51
52

IMPORTANT

Only the boiler coding card supplied with the standard equipment of the boiler may be used. The coding card is enclosed in the accessory pack of the boiler.

1. Push boiler coding card through recess in the cover and insert it into plug-in location "X7".

IMPORTANT

If the boiler coding card is not installed the following fault code will be displayed on the boiler control:
"87".

Initial Start-Up



Burner instructions.

! WARNING

Verify completeness of all discussion points on the following pages before starting-up system.

1. Ensure fresh air intake of boiler room is open and that chimney and all flue pipes are connected, sealed and unobstructed inside.

2. Ensure proper size and operation of expansion tank. Undersized expansion tanks cause fresh water to be added to the system through fill valve. This will cause premature section failure, which is not covered by warranties.

3. Fill heating system with water and bleed out air completely. Ensure complete system is properly vented of air.

4. Perform a pressure test of the boiler and the water piping. Pressure test must not exceed 1 ½ times the maximum operating pressure (45 psi) of the boiler. Pressure relief valve must be removed during pressure test. Any leaks must be corrected.

■ *the max. operating pressure is 45 psig / 310 kPa*

■ *the max. testing pressure is 68 psig / 465 kPa.*

5. Ensure proper and adequate fuel supply exists; open oil shut-off valve.

→ *If the nitrogen pressure of the precharged expansion tank is less than the static pressure of the system, inflate membrane pressure to slightly exceed pressure of system. The static pressure required at the tank is based upon the static height of the system. Normal fill pressure for most residential applications is 12 to 15 psig when the system is cold. A lower pressure gage reading usually indicates loss of water due to leakage. All leaks must be corrected. Refer to instructions packaged with automatic fill valve. Follow local regulations with respect to backflow preventers.*

→ *Water treatment should be considered in areas where it is known that boiler feed water contains a high mineral content and hardness. Contact local water treatment company.*

In areas where freezing might occur, an antifreeze may be added to the system water to protect the system. Please adhere to the specifications given by the antifreeze manufacturer. Do not use automotive silicate-based antifreeze. Ensure a copy of the Material Safety Data Sheet is left on site.

Please observe that an antifreeze/water mixture may require a backflow preventer within the automatic water feed and influence components such as diaphragm expansion tanks, radiation, etc. A 40% antifreeze content will provide freeze-up protection to -10°F / -23°C. Do not use antifreeze other than specifically made for hot water heating systems. System also may contain components which might be negatively affected by antifreeze. Check total system frequently when filled with antifreeze. Follow anti-freeze manufacturer's instructions.

Initial Start-Up *(continued)*

Burner calibration

 *Instructions supplied with Beckett or Riello burner*

Combustion analysis

This oil burner requires combustion measurements performed at the final installation site, using calibrated combustion equipment, to verify factory settings, or to be used as a guide in changing burner settings to suite local conditions.

Examples of local conditions which influence combustion results include: weather conditions, length of horizontal vent pipe, diameter and height of the chimney, side wall venting (power vent), altitude above sea level, quality and heating value of oil used, maximum number of other fuel burning appliances running at the same time. These conditions affect the burner set-up. The burner must be adjusted for acceptable combustion results under local conditions of the installation.

Combustion measurements (CO₂, stack temperature, draft and CO) are taken in the flue pipe between boiler and barometric draft regulator before dilution air (see the installation manual). Overfire draft is measured at the combustion chamber observation port opening. Over-fire draft ranges from 0 to +0.01 "w.c.. Breeching draft is approximately -0.02 "w.c..

Note: This boiler is approved for operation with a breeching draft of up to -0.08 "w.c. (when used without a barometric draft regulator).

The expected CO₂ average range for #2-oil is from 11.0% to 13.0%.

For burner technical data see table on following page.

 **WARNING**
DO NOT USE GASOLINE CRANKCASE DRAININGS OR ANY OIL CONTAINING GASOLINE.

 **WARNING**
Always keep the manual fuel supply valve shut off if the burner is shut down for an extended period of time.

 **WARNING**
Do not tamper with the unit or controls.

 **WARNING**
DO NOT START THE BURNER UNLESS THE COMBUSTION CHAMBER DOOR IS SECURED IN PLACE.

 **WARNING**
DO NOT ATTEMPT TO START THE BURNER WHEN EXCESS OIL HAS ACCUMULATED, WHEN THE UNIT IS FULL OF VAPOR, OR WHEN THE COMBUSTION CHAMBER IS VERY HOT.

 **WARNING**
Do not fire boiler without water.

 **WARNING**
Do not leave any tools inside combustion chamber.

 *For direct vent application, please refer to the Direct Vent System Installation Instructions, Part No. 5351 050.*

Initial Start-Up *(continued)*

Beckett burner calibration

Boiler model	Model No.	VR1-22	VR1-27	VR1-33
Burner model	Beckett	NX-VI 701	NX-VI 702	NX-VI 703
Fuel type	oil	No. 2 fuel oil		
Pump pressure	psig	190	175	175
Oil nozzle	Danfoss	n.a.	0.60x60°AS	n.a.
	Delavan	0.50x60°B	n.a.	0.75x60°A/W
	Hago	0.50x60°B	0.60x60°B	n.a.
Oil nozzle flow rate	GPH@psig	0.65@190	0.75@175	1.00@175
Air tube length	inches	7	7	7
	mm	178	178	178
Air tube insertion	inches	3¼	3¼	3 ⁵ / ₈
	mm	83	83	92
Air tube combination		NX70LP	NX70LP	NX70LJ
Head type		6-slot	6-slot	9-slot
Head setting		2.00	2.50	3.25
Air setting		see head setting		
Static plate		n.a.		
Baffle		n.a.		
Fuel pump		21844	21844	21844
Flange		32073	32073	32073

Initial Start-up

Initial Start-Up *(continued)*

Riello burner calibration*1

Boiler model	Model No.	VR1-22	VR1-27	VR1-33
Burner model	Riello 40 Series	F3	F3	F5
Fuel type	oil	No. 2 fuel oil		
Pump pressure	psig	175	175	175
Oil nozzle	Danfoss	0.5x60°xAS	0.6x60°xAS*3	0.75x60°xAS
	Delavan	0.5x60°xSS	0.6x60°xW	0.75x60°xA 0.75x60°xW*2
	Hago	0.5x60°xSS*2	0.6x60°xES	n.a.
Oil nozzle flow rate	GPH@psig	0.65@175	0.75@175	1.00@175
Air tube length	inches	7	7	6 ⁵ / ₁₆
	mm	178	178	160
Air tube insertion	inches	4 ⁵ / ₈	4 ⁵ / ₈	4 ¹ / ₄
	mm	118	118	108
Turbulator setting		0.0	2.0	0.8
Air gate setting		3.1	3.4	2.9

IMPORTANT

*1 For VR1-27 boiler, replace installed nozzle with nozzle packaged with Riello burner.

*2 Factory-installed nozzle.

*3 Nozzles must be installed by installer.

Note: Riello oil burners are factory set for Vitorond 100, VR1-22, and -33 boilers and should only require minor adjustments. Install appropriate nozzle and set the burner for model VR1-27.

Barometric draft regulator

When a barometric draft regulator is used, adjust the barometric draft regulator such that the over-fire draft is 0.00 to +0.01 "w.c., while the breech draft is approximately -0.02 "w.c.

During operation of the burner, the barometric draft regulator installed in the vent system must move freely.

Installation Examples

General

The schematics on the following pages are to be seen as guidelines only. They further do not display all system varieties, safety devices, or concepts possible. Specific system layouts may be further discussed with the local Viessmann sales representative office.

Clearances

A minimum of 2" circumferential clearance from non-insulated hot water pipes to combustible construction must be maintained. In cases where the pipes are insulated with pipe insulation of appropriate and sufficient thickness and insulation values, the above clearance may be reduced to 0".

Waterside flow

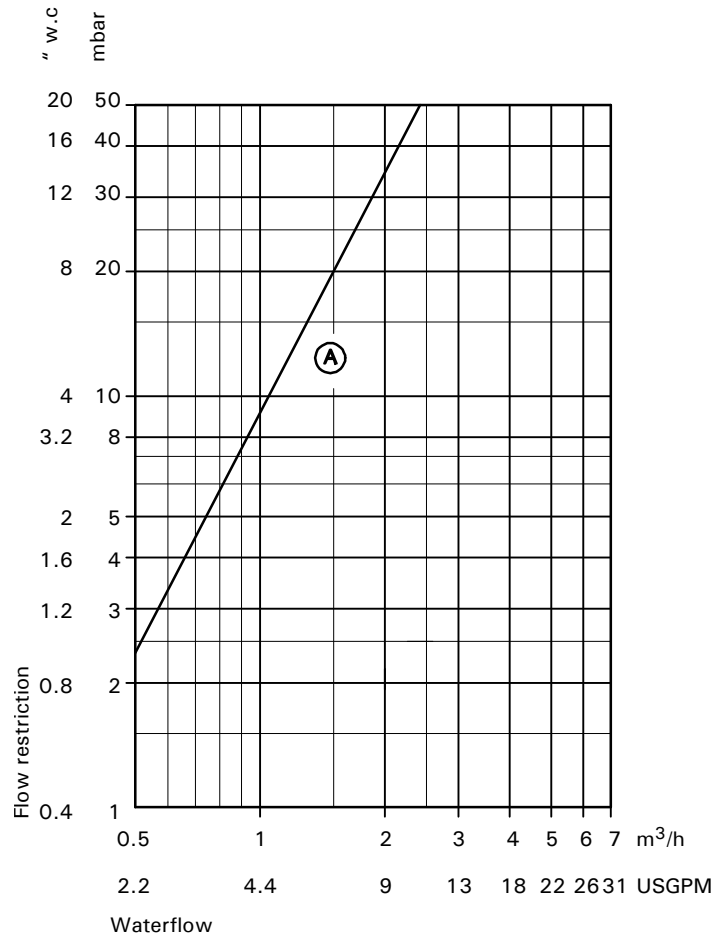

Ⓐ VR1-22 to -33

Flow rates

The relationship between boiler flow rate and temperature rise is according to the formula:

$$\text{Boiler output (Btu/h)} = 500 \times \text{flow (USGPM)} \times \text{Rise (}^\circ\text{F)}$$

The following chart lists typical flow rates for the Vitorond boiler:

Boiler Model	VR1	-22	-27	-33
20°F rise	USGPM	8	9.2	12.2
30°F rise	USGPM	5.3	6.1	8.1

Installation Examples - Aquastat

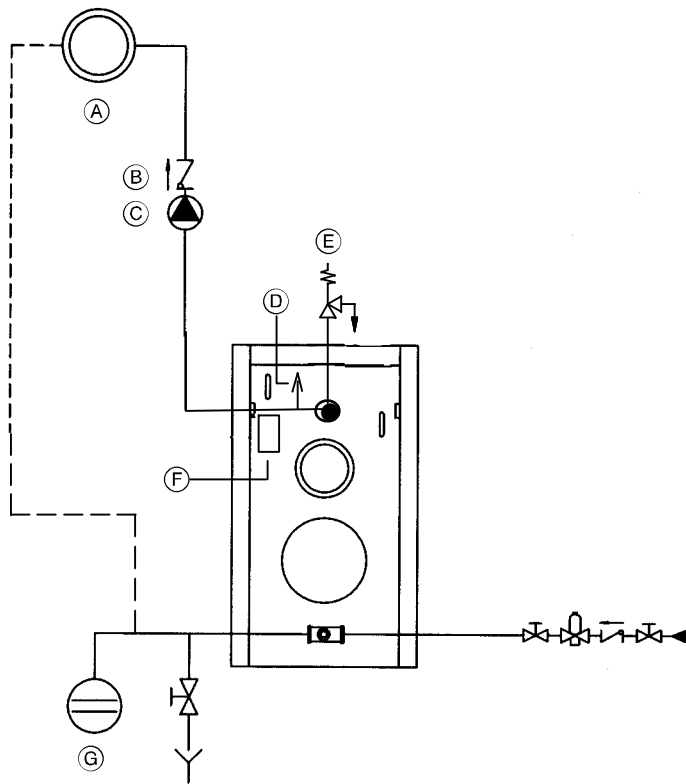

- Ⓐ Heating circuit
- Ⓑ Spring-loaded flow check valve
- Ⓒ Circulation pump
- Ⓓ Automatic air vent
- Ⓔ Pressure relief valve
- Ⓕ High limit control
- Ⓖ Expansion tank

Fig. 52

Special Applications - Aquastat

Boiler in a heating/cooling application

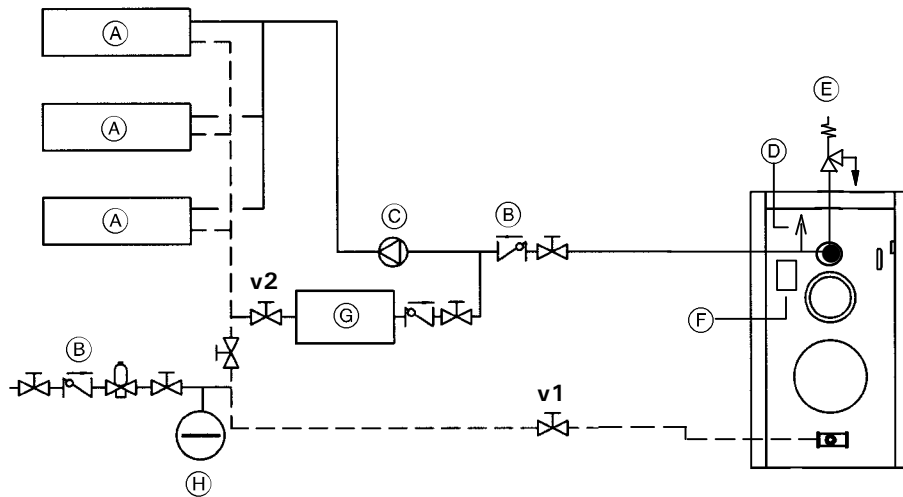

Cooling season starts:
close valve v1 and open valve v2

Heating season starts:
close valve v2 and open valve v1

- (A) Heating/Cooling unit
- (B) Spring-loaded flow check valve
- (C) Circulation pump
- (D) Automatic air vent
- (E) Pressure relief valve
- (F) High limit control
- (G) Water chiller
- (H) Expansion tank

Fig. 53

IMPORTANT

We strongly suggest that the valves pictured above be labelled "v1" and v2."

Low water cut-off

A low water cut-off may be required by local codes. If boiler is installed above radiation level, a low water cut-off device (A) of approved type (field supplied) must be installed in all instances. Do **not** install an isolation valve between boiler and low water cut-off.

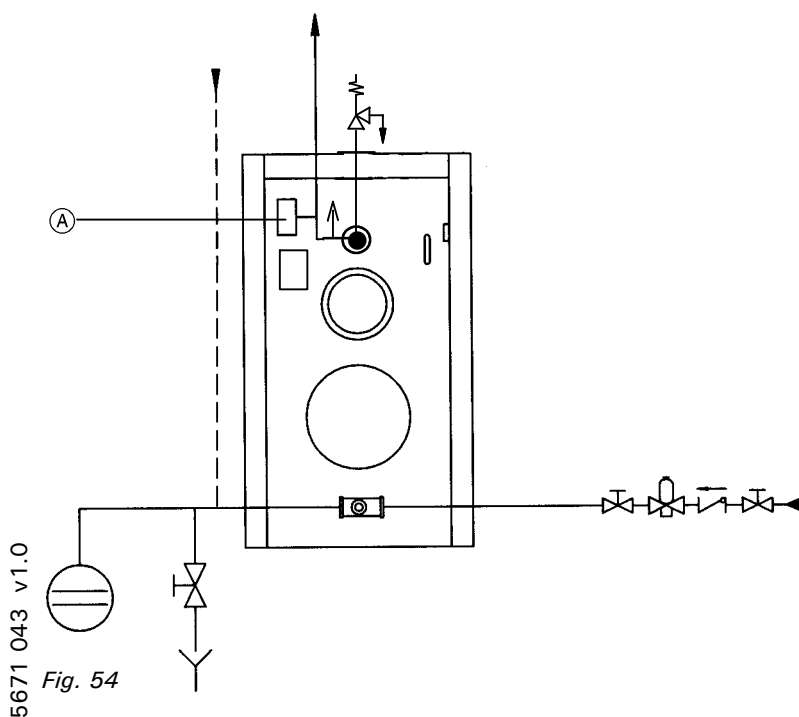

5671 043 v1.0
Fig. 54

Installation Examples - Vitotronic

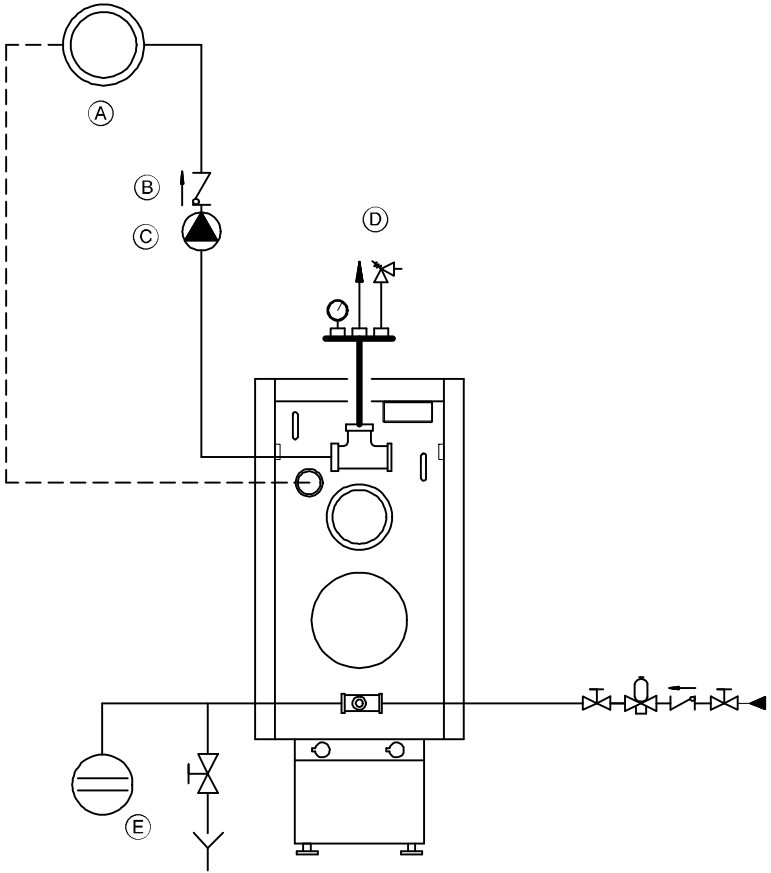

Without mixing valve
e.g. with Vitotronic 100, Model KW10B

- Ⓐ Heating circuit
- Ⓑ Spring-loaded flow check valve
- Ⓒ Circulation pump
- Ⓓ Automatic air vent (field supplied), pressure relief valve, and temperature pressure gage
- Ⓔ Expansion tank

Fig. 55

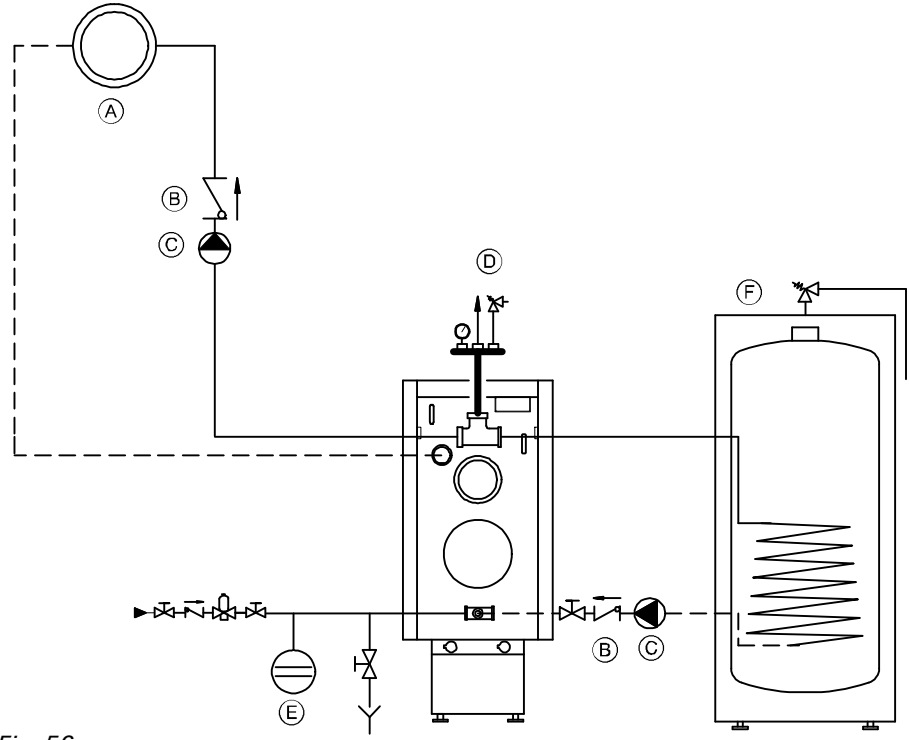

Without mixing valve and with DHW
e.g. with Vitotronic 100, KW10B

- Ⓐ Heating circuit
- Ⓑ Spring-loaded flow check valve
- Ⓒ Circulation pump
- Ⓓ Automatic air vent (field supplied), pressure relief valve, and temperature pressure gage
- Ⓔ Expansion tank
- Ⓕ Domestic hot water storage tank (indirect-fired)

Fig. 56

Installation Examples - Vitotronic (continued)

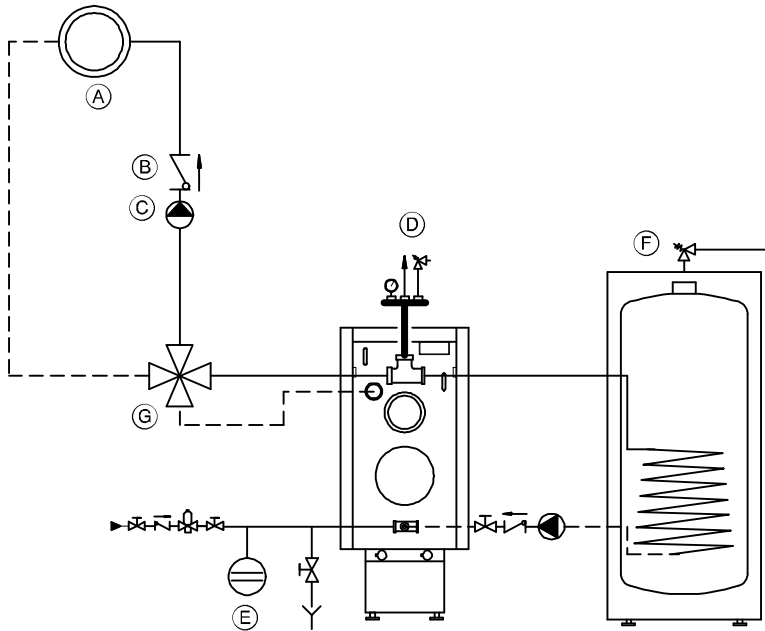

Fig. 57

With one low-temperature circuit with 4-way mixing valve, and with domestic hot water production

e.g. with Vitotronic 200, Model KW2 combined with one Mixing Valve Actuator Accessory Kit

- (A) Heating circuit
- (B) Spring-loaded flow check valve
- (C) Circulation pump
- (D) Automatic air vent (field supplied), pressure relief valve, and temperature pressure gage
- (E) Expansion tank
- (F) Domestic hot water storage tank (indirect-fired)
- (G) 4-Way mixing valve

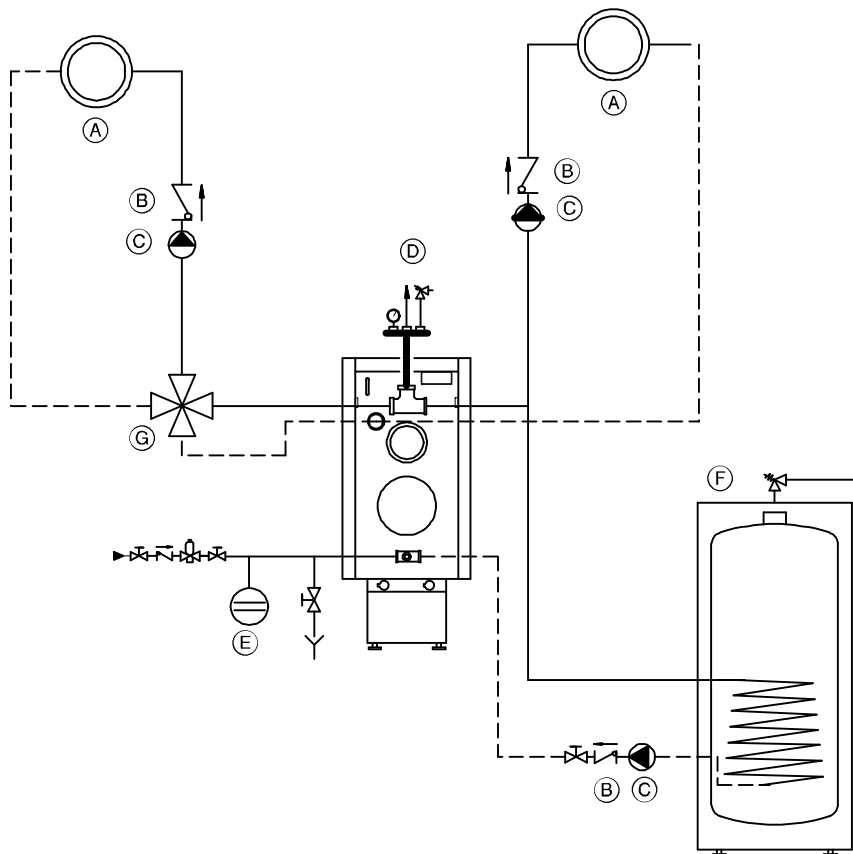

Fig. 58

With one low-temperature circuit with 4-way mixing valve, and one high temperature circuit, and with domestic hot water production

e.g. with Vitotronic 200, Model KW2 combined with one Mixing Valve Actuator Accessory Kit

- (A) Heating circuit
- (B) Spring-loaded flow check valve
- (C) Circulation pump
- (D) Automatic air vent (field supplied), pressure relief valve, and temperature pressure gage
- (E) Expansion tank
- (F) Domestic hot water storage tank (indirect-fired)
- (G) 4-Way mixing valve

Special Applications - Vitotronic

Boiler in a heating/cooling application

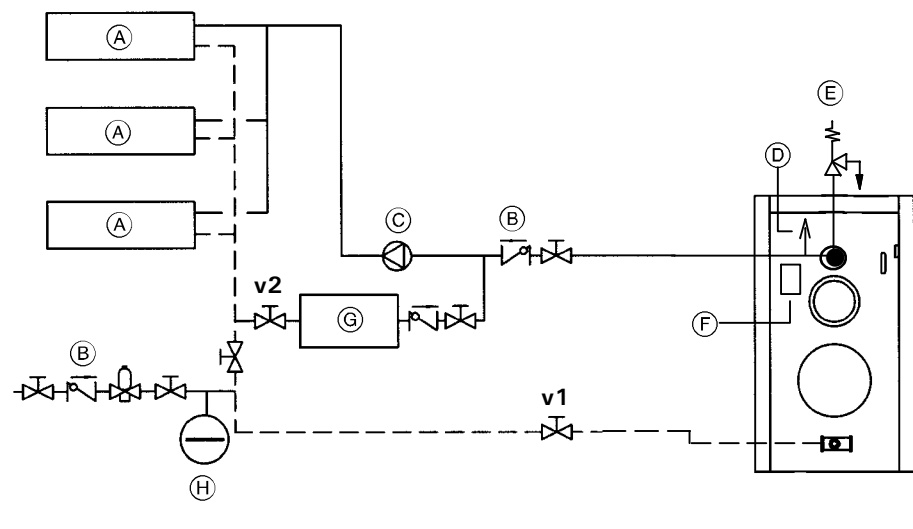

Cooling season starts:
close valve v1 and open valve v2

Heating season starts:
close valve v2 and open valve v1

- (A) Heating/Cooling unit
- (B) Spring-loaded flow check valve
- (C) Circulation pump
- (D) Automatic air vent,
- (E) Pressure relief valve
- (F) High limit control
- (G) Water chiller
- (H) Expansion tank

Fig. 59

IMPORTANT

We strongly suggest that the valves pictured above be labelled "v1" and v2."

Low water cut-off

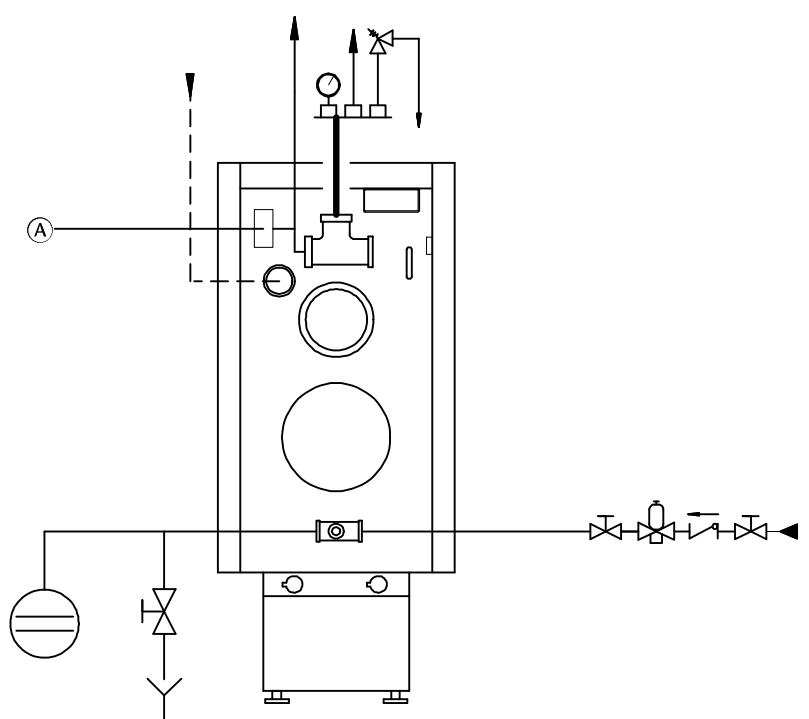

A low water cut-off may be required by local codes. If boiler is installed above radiation level, a low water cut-off device (A) of approved type (field supplied) must be installed in all instances. Do **not** install an isolation valve between boiler and low water cut-off.

Fig. 60

Service Procedure Overview

Service steps



S	1. Shut down heating system	Page 64
S	2. Open combustion chamber door	Page 64
S	3. Clean heat exchanger and flue pipe	Page 65
S	4. Check all gaskets and insulation	Page 65
S	5. Close combustion chamber door	Page 66
S	6. Check heating system and domestic hot water connections	Page 66
S	7. Ensure proper operation of all safety devices	Page 66
S	8. Ensure proper operation of expansion tank, low water cut-off (if applicable) and pumps	Page 67
S	9. Ensure that an adequate supply of combustion air exists in the boiler room	Page 67
S	10. Ensure functionality of the barometric draft regulator of the burner	Page 67
S	11. Calibrate the burner	Page 68

Necessary Tools

Testing/analysis equipment
Calibrated flue gas analyzer

Cleaning supplies
Hand brush
Rags
Vacuum cleaning

Possible replacement parts
Rope sealant for combustion chamber door
Refractory for combustion chamber door

Use only calibrated equipment.

! WARNING

Ensure that warning concerning fiberglass wool and ceramic fiber materials on page 3 has been read and understood before handling insulation.

! WARNING

NEVER ADJUST BURNER BY EYE.

Service Procedure

1. Shut-down heating system

1. Ensure main power supply to equipment, the heating system, and all external controls has been deactivated. Take precautions in both instances to avoid accidental activation.
2. Close main oil supply valve near burner and near tank.

! WARNING

Always keep the manual fuel supply valve shut off if the burner is shut down for an extended period of time.

2. Open combustion chamber door

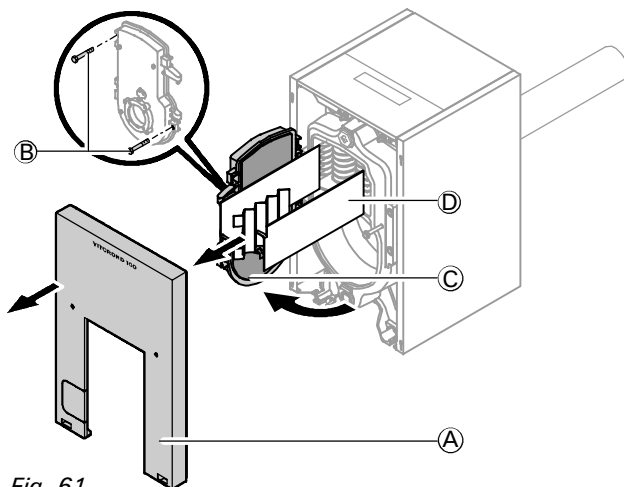

Fig. 61

1. Disconnect power supply.
2. Remove front panel (A) by lifting panel up and out.
3. Remove two bolts (B) of combustion chamber door (C) and open.

! WARNING

Never burn garbage or paper in the unit, and never leave combustible material around it.

Continued on following page.

Service Procedure *(continued)*

2. Open combustion chamber door *(continued)*

4. Remove turbulators ④, if applicable.
See page 70 for details.
5. Remove combustion chamber insert (if applicable).

3. Clean heat exchanger and flue pipe

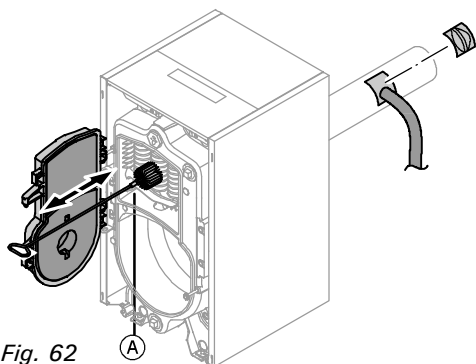

Fig. 62

1. Clean heat exchanger with cleaning brush ① and use vacuum cleaner to remove all sediment.
2. Remove all sediment from flue pipe and flue gas collector using vacuum cleaner.

4. Check all gaskets and insulation

⚠ WARNING

Ensure that warning concerning fiberglass wool and ceramic fiber materials on page 3 has been read and understood before handling insulation.

1. Check all gaskets and the sealant rope of the combustion chamber door for wear or damage.
2. Check the combustion chamber door refractory for wear or damage.
3. Replace worn or damaged parts.

Service Procedure *(continued)*

5. Close combustion chamber door

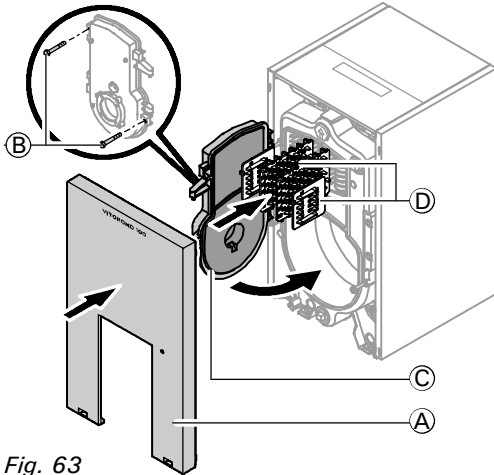

Fig. 63

1. Reinsert flue gas turbulators (D) (if applicable).
2. Reinstall combustion chamber insert (if applicable).
3. Close combustion chamber door (C) and tighten two bolts (B) in an even fashion.

WARNING

Reconnect oil burner and follow instructions found in burner installation/start-up manual.

4. Install front panel (A).
5. Fasten burner hood (if applicable) and lock in place .

WARNING

Do not leave any tools inside combustion chamber.

6. Check heating system and domestic hot water connections

Ensure all connections are pressure tight.

7. Ensure proper operation of all safety devices

Check pressure gage, air vent and pressure relief valve. Ensure pressure relief valve does not leak. Also ensure pressure relief valve operates in accordance with information provided by the manufacturer.

Service Procedure *(continued)*

8. Ensure proper operation of expansion tank, low water cut-off (if applicable) and pumps

Refer to maintenance instructions supplied with diaphragm expansion tanks, low water cut-offs, pumps, etc.

Flush float water type low water cut-offs (if used).

The usual water fill pressure is between 10 and 15 psi with the system cold. A lower pressure gage reading usually indicates loss of water due to leakage. All leaks must be corrected. Refer to instructions packaged with automatic fill valve. Follow local regulations with respect to backflow preventers.

If oil-lubricated pumps are used, ensure proper lubrication.

If motorized zone valves are used, refer to maintenance instructions provided with zone valves.

If an older non-diaphragm expansion tank is used, ensure the correct water level is present.

9. Ensure that an adequate combustion air supply exists in the boiler room

Ensure fresh air intake of boiler room is open. This opening must never be blocked or partially covered.

10. Ensure functionality of the barometric draft regulator of the burner

During operation of the burner, the barometric draft regulator installed in the vent system must move freely.

Service Procedure *(continued)*

11. Calibrate the burner

► For burner technical information see technical data table on pages 55 and 56.

 *Instructions supplied with Beckett or Riello burner*

Combustion analysis

This oil burner requires combustion measurements performed at the final installation site, using calibrated combustion equipment, to verify factory settings, or to be used as a guide in changing burner settings to suite local conditions.

Examples of local conditions which influence combustion results include: weather conditions, length of horizontal vent pipe, diameter and height of the chimney, side wall venting (power vent), altitude above sea level, quality and heating value of oil used, maximum number of other fuel burning appliances running at the same time. These conditions affect the burner set-up. The burner must be adjusted for acceptable combustion results under local conditions of the installation.

Combustion measurements (CO₂, stack temperature, draft and CO) are taken in the flue pipe between boiler and barometric draft regulator before dilution air (see the installation manual). Overfire draft is measured at the combustion chamber observation port opening. Over-fire draft ranges from 0 to +0.01 "w.c.. Breeching draft is approximately -0.02 "w.c..

Note: This boiler is approved for operation with a breeching draft of up to -0.08 "w.c. (when used without a barometric draft regulator).

The expected CO₂ average range for #2-oil is from 11.0% to 13.0%.

 **WARNING**
DO NOT USE GASOLINE CRANKCASE DRAININGS OR ANY OIL CONTAINING GASOLINE.

 **WARNING**
Always keep the manual fuel supply valve shut off if the burner is shut down for an extended period of time.

 **WARNING**
Do not tamper with the unit or controls.

 **WARNING**
DO NOT START THE BURNER UNLESS THE COMBUSTION CHAMBER DOOR IS SECURED IN PLACE.

 **WARNING**
DO NOT ATTEMPT TO START THE BURNER WHEN EXCESS OIL HAS ACCUMULATED, WHEN THE UNIT IS FULL OF VAPOR, OR WHEN THE COMBUSTION CHAMBER IS VERY HOT.

 **WARNING**
Do not fire the boiler without water.

 **WARNING**
Do not leave any tools inside the combustion chamber.

 *For direct vent application, please refer to the Direct Vent System Installation Instructions, Part No. 5351 050.*

Parts List

Model No.	Serial No.
VR1-22	7249048□□□□□□□□
VR1-27	7249049□□□□□□□□
VR1-33	7249050□□□□□□□□

Ordering Replacement Parts:
 Please provide boiler Model and Serial Number from rating plate when ordering replacement parts. Order replacement components from your Viessmann distributor.

Parts

- 202 Top panel, front
- 203 Side panel, left
- 204 Insulation blanket
- 205 Back panel
- 206 Insulation blanket, rear
- 207 Front panel
- 208 Support bracket
- 209 Top panel, rear
- 210 Side panel, right
- 211 Nameplate "Vitorond 100"
- 212 Cover, edgemolding
- 215 Cover plate
- 509 Vitotronic retrofit housing

Other Parts (not illustrated)

- 300 Touch-up spray paint, Vitotec silver
- 301 Touch-up paint stick, Vitotec silver
- 400 Installation fittings for aquastat applications
- 500 Installation fittings for Vitotronic applications
- 600 Installation, Service and Operating Instructions
- 601 Installation Instructions, Direct Vent
- 602 Warranty Sheet, Cast Iron / Residential

Ⓐ Rating plate (location of serial no.)

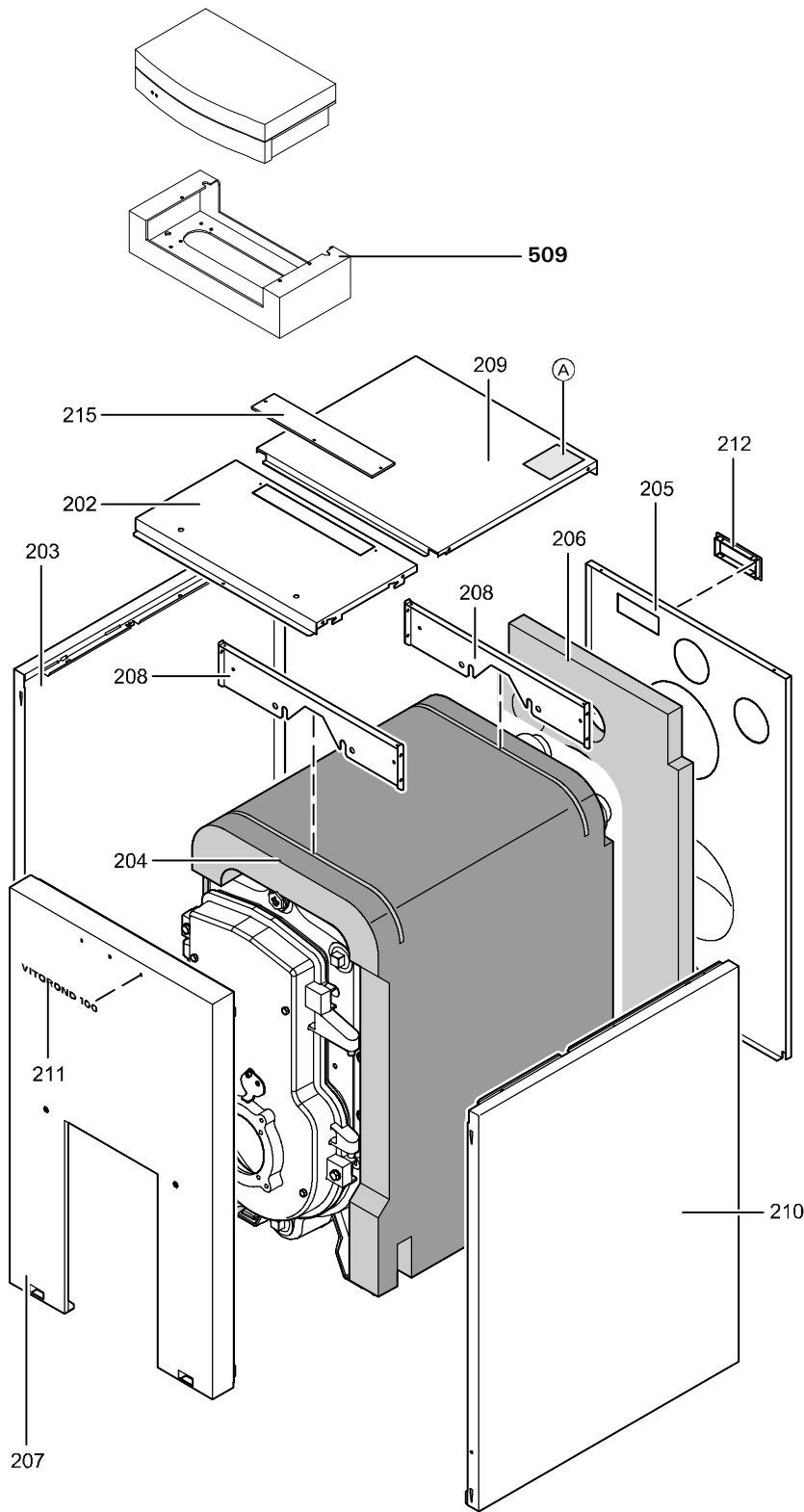

Fig. 64

Additional Information

Parts List *(continued)*

Parts

- 001 5-Point sensor well
- 002 Combustion chamber door refractory
- 003 Combustion chamber door
- 004 Hinge bracket
- 005 Glass-fiber gasket, 16 x 12 L=2000mm
- 006 Glass-fiber gasket, 3x116mm *1
- 008 Observation port cover
- 011 Turbulator insert, x2 2nd pass, VR1-22 *2
- 012 Turbulator insert, x2, VR1-33 *3
- 014 Turbulator insert, x1, VR1-33 *3
- 023 Combustion chamber insert

400 Installation fittings

for aquastat applications

- 401 Sediment faucet, 3/4" NPT
- 402 Pressure relief valve, 30psig
- 403 Vent pipe adaptor, 5"
- 404 Sensor well
- 405 Accessory Pack, burner installation hardware
- 406 Temperature and pressure gage
- 407 Aquastat
- 408 Burner cable 85", 4-wire *4

500 Installation fittings

for Vitotronic applications

- 501 Sediment faucet, 3/4" NPT
- 502 Pressure relief valve, 30psig
- 503 Vent pipe adaptor, 5"
- 504 Junction box *4
- 505 Accessory Pack, burner installation hardware
- 506 Temperature and pressure gage
- 507 Control cable with #41 plug *4
- 508 Burner cable (#41) *4
- 509 Vitotronic retrofit housing *4
- 510 Return injector nozzle

Wear Parts

- 016 Cleaning brush handle 800mm, M10 *5
- 017 Cleaning brush (no handle) *5

- *1 Sold with adhesive
- *2 for VR1-22 only
- *3 for VR1-33 only
- *4 not shown on diagram
- *5 optional - not standard equipment of boiler

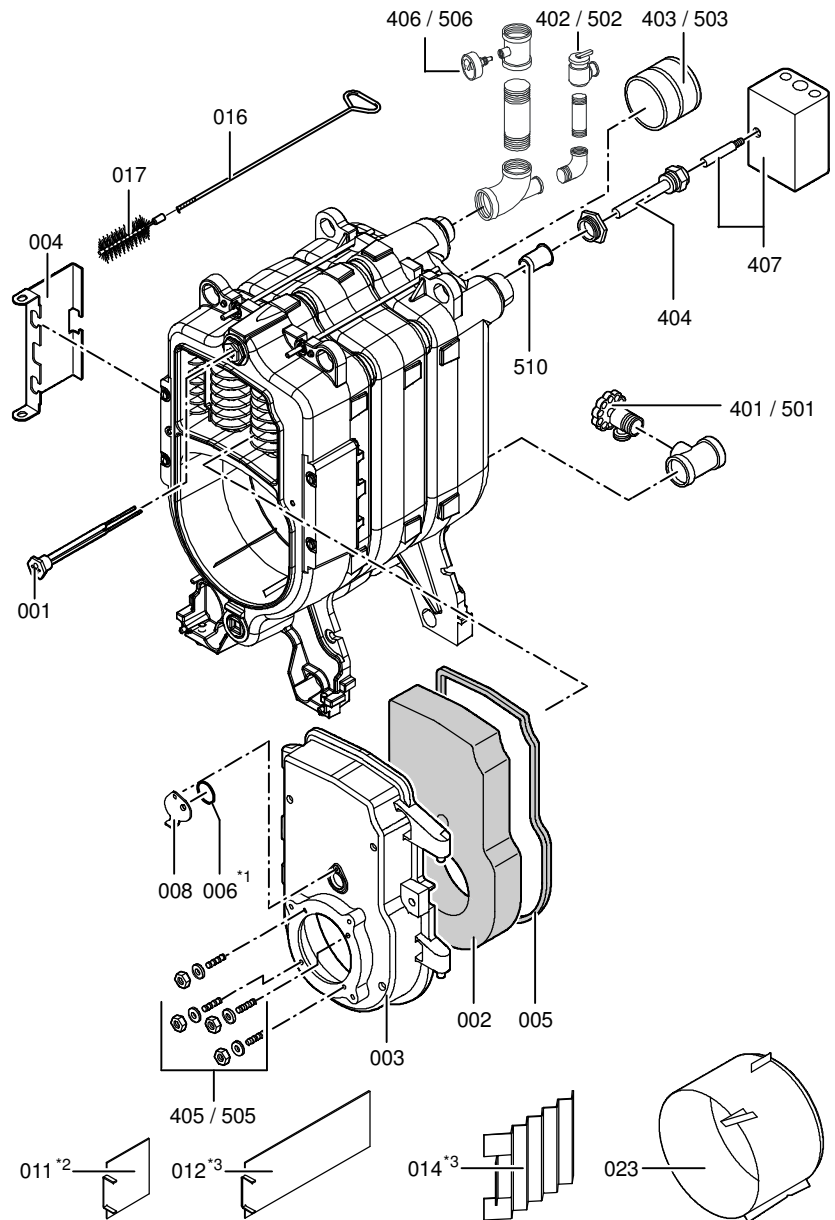

Fig. 65

Parts List *(continued)*

Parts

Installation Set

7838 763

VITOROND 100 VR1 Series

for use with Aquastat control only!

Model No.	Serial No.
VR1-22	7249048□□□□□□□□
VR1-27	7249049□□□□□□□□
VR1-33	7249050□□□□□□□□

Parts

- 401 Electronic aquastat
- 402 Sensor well
- 403 Hex bushing, 1 ¼" x ¾"
- 404 Temperature and pressure gage
- 405 Reduction tee, 1 ½" x 1 ½" x ½"
- 406 Nipple, 1 ½" x 5"
- 407 Reduction tee, 1 ½" x ¾" x 1 ½"
- 408 90° Street elbow, ¾"
- 409 Nipple, ¾" x 3 ½"
- 410 Pressure relief valve, 30 psig
- 411 Reduction tee, 1 ½" x 1 ½" x ¾"
- 412 Sediment faucet
- 413 Vent pipe adaptor, 5"
- 415 Burner cable 85" (4-wire)
- 421 Cable clamps
- 422 Outdoor reset kit

Other Parts (not illustrated)

- 417 Accessory pack (burner installation hardware)
- 500 Installation, Operation and Service Instructions
- 501 Installation Instructions, Direct Vent
- 502 Warranty Sheet
- 503 Cast-Iron, Residential Parts List

- (A) Vitorond boiler see separate Parts List
- (B) Label "Burner information details"

Front View

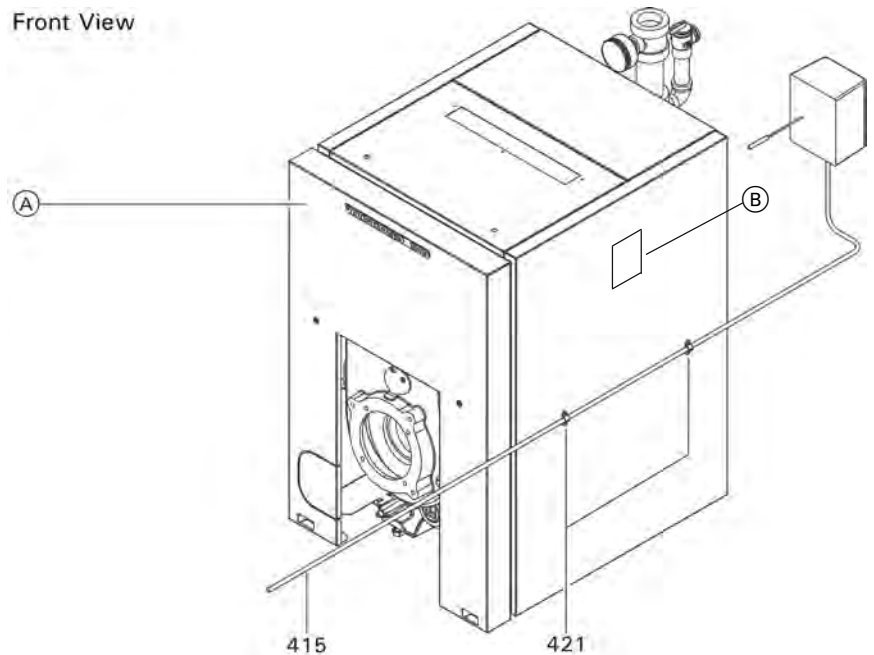

Rear View

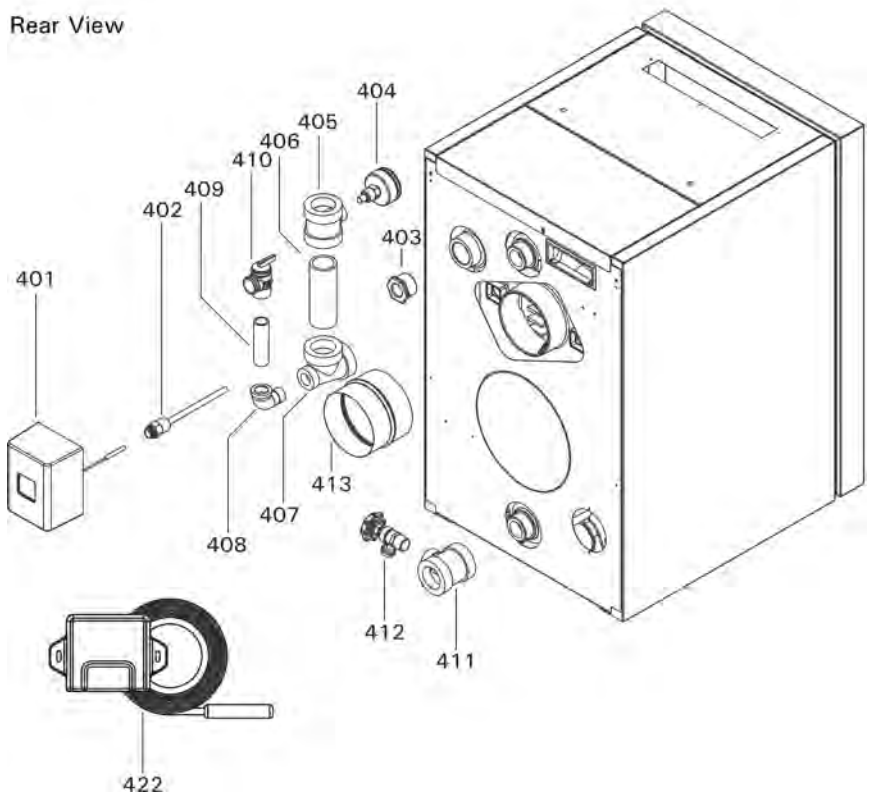

Maintenance Record

	Start-up	Maintenance/Service	Maintenance/Service	Maintenance/Service	Maintenance/Service
on:					
by:					

	Maintenance/Service	Maintenance/Service	Maintenance/Service	Maintenance/Service	Maintenance/Service
on:					
by:					

	Maintenance/Service	Maintenance/Service	Maintenance/Service	Maintenance/Service	Maintenance/Service
on:					
by:					

	Maintenance/Service	Maintenance/Service	Maintenance/Service	Maintenance/Service	Maintenance/Service
on:					
by:					

- Before each heating season begins, have the following service and maintenance done by a licensed, professional heating contractor:
1. Boiler heat exchanger inspected and cleaned.
 2. Vent system inspected for deterioration, leaks, corrosion, proper draft, and proper operation. Check vent system for compliance with local and national code requirements. Repair or replace as required.
 3. Burner checked, and if necessary, adjusted for proper combustion and operation. Check for adequate supply of fresh outside combustion and ventilation air.

 **WARNING**

Neglecting to perform necessary maintenance can cause unsafe operation.

Viessmann Manufacturing Company Inc.
 750 McMurray Road
 Waterloo, Ontario • N2V 2G5 • Canada
TechInfo Line 1-888-484-8643
 1-800-387-7373 • Fax (519) 885-0887
 www.viessmann.ca • info@viessmann.ca

Viessmann Manufacturing Company (U.S.) Inc.
 45 Access Road
 Warwick, Rhode Island • 02886 • USA
TechInfo Line 1-888-484-8643
 1-800-288-0667 • Fax (401) 732-0590
 www.viessmann-us.com • info@viessmann-us.com

Printed on environmentally friendly (recycled and recyclable) paper.



5671 043 v1.0 Technical information subject to change without notice