

# Technical Data Manual

Model Nos. and pricing: see Price List



## Vitorond 100

### VR1 Series

#### Oil-Fired Boiler

of cast iron sectional construction  
for hydronic heating systems  
with modulating boiler water temperatures  
Heating input: 91 to 245 MBH  
27 to 72 kW

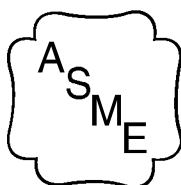

### VITOROND 100

A genuine triple-pass boiler of cast iron sectional design. The high-quality construction and innovative oil heating technology of this boiler provide a high level of operational reliability, high-efficiency operation and reduced emissions.

#### The benefits at a glance:

- **Get the most out of your fuel dollar!**  
Maximum heat extraction with triple-pass design. A.F.U.E.: up to 86.9%.
- **Extremely durable** cast iron heat exchanger for **maximum reliability and service life.**
- **Clean combustion** with Beckett or Riello burner.
- Integrated stainless steel combustion chamber insert for **clean and efficient combustion.**
- Thick 3½" insulation for extremely low standby losses and **fuel savings.**
- **Easy access**  
Full-swing left- or right-hinged combustion chamber door.
- **Low maintenance cost** with service-friendly burner and easy-to-clean flue gas passageways.
- Spacious, wet-base water walls prevent deposits, reduce stress and **increase boiler life.**
- **Direct vent option** (up to VR1-33) eliminates the need for a chimney and combustion air supply opening.
- **Multiple control options:**  
Choose from a standard 24 VAC room thermostat or Vitotronic control options for **additional energy savings.**
- **Additional energy savings and reduced emissions** with modulating boiler water temperatures when using Vitotronic control options.
- Boiler return injector available with Vitotronic controls protects against formation of condensation and enables safe lower-temperature operation for **increased efficiency.**

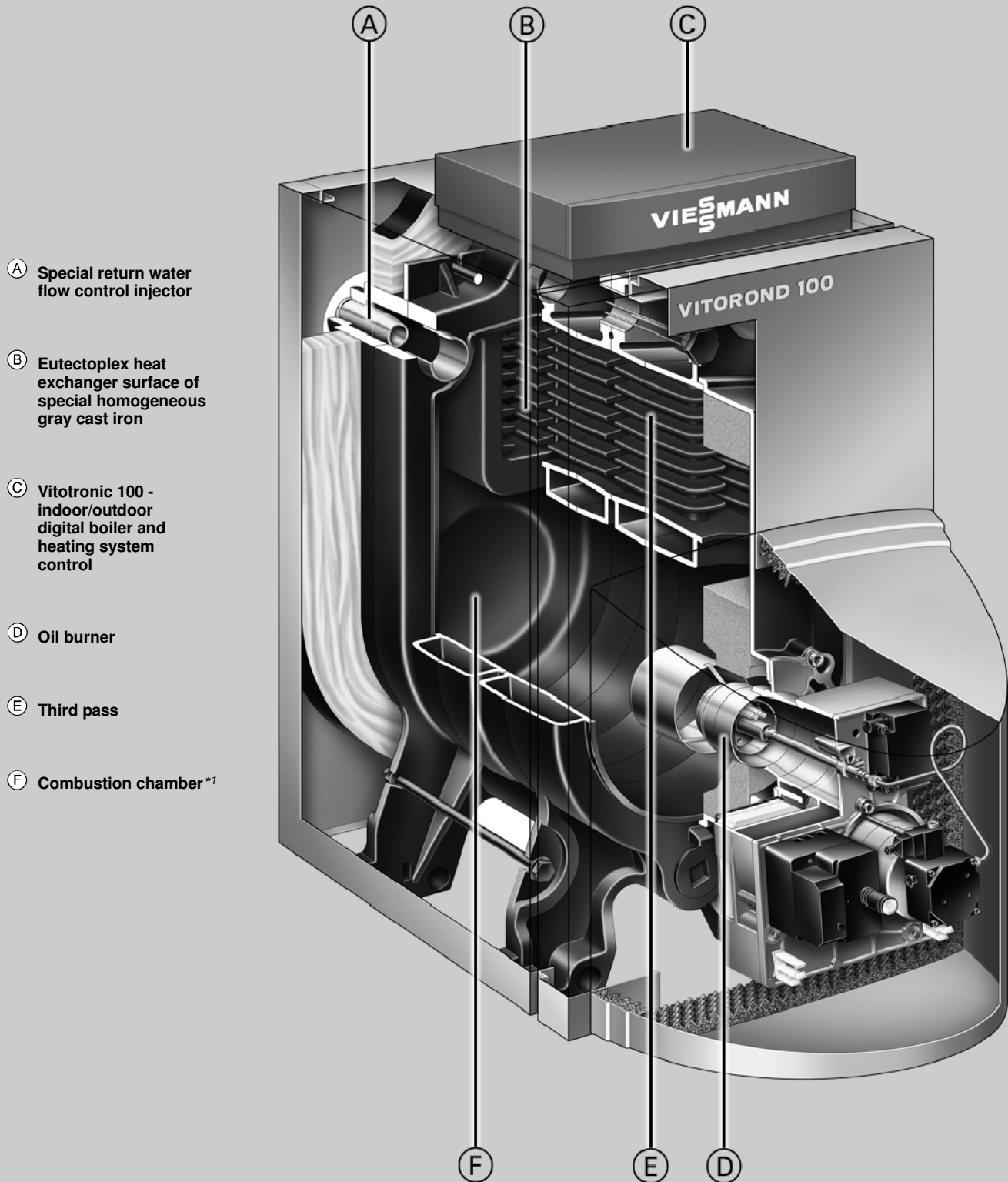

<sup>\*1</sup> Stainless steel combustion chamber insert not shown.  
Boiler/burner and controls combination may not be exactly as illustrated.

# Technical Data

## Technical data

Boiler Model	Model No.	VR1-22	VR1-27	VR1-33	VR1-40	VR1-50	VR1-63
<b>CSA input</b> <sup>*1</sup>	MBH	91	105	140	161	196	245
	kW	27	31	41	47	57	72
	GPH	0.65	0.75	1.0	1.15	1.4	1.75
<b>CSA output</b>	MBH	80	92	122	140	172	215
	kW	23	27	36	41	50	63
<b>Net I = B = R rating</b>	MBH	70	80	106	122	150	187
	kW	21	23	31	36	44	55
<b>A.F.U.E.</b>	%	86.8	86.8	86.8	86.9	86.9	86.9
<b>Boiler dimensions</b>							
Depth (without burner)	inches	25½	31	31	24½	29½	34½
	mm	650	790	790	583	710	837
Width	inches	15½	15½	15½	20	20	20
	mm	391	391	391	512	512	512
Height	inches	30½	30½	30½	37	37	37
	mm	775	775	775	935	935	935
<b>Overall dimensions (with jacket)</b>							
Total depth (includes burner)	inches	38½	44	44	36	37½	42½
	mm	976	1116	1116	914	956	1081
Total width	inches	19¾	19¾	19¾	22¼	22¼	22¼
	mm	500	500	500	565	565	565
Total height (without Vitotronic)	inches	33	33	33	39¾	39¾	39¾
	mm	840	840	840	1010	1010	1010
- Height 1 (control unit in position for operation and programming)	inches	43 <sup>7</sup> / <sub>8</sub>	43 <sup>7</sup> / <sub>8</sub>	43 <sup>7</sup> / <sub>8</sub>	50½	50½	50½
	mm	1115	1115	1115	1285	1285	1285
- Height 2 (control unit in position for servicing)	inches	52¾	52¾	52¾	59½	59½	59½
	mm	1340	1340	1340	1510	1510	1510
Height of boiler stand	inches	9¾	9¾	9¾	9¾	9¾	9¾
	mm	250	250	250	250	250	250
<b>Weight boiler block</b>	lbs	280	353	353	414	527	639
	kg	127	160	160	188	239	290
<b>Total weight, boiler with insulation, burner and boiler control</b>	lbs	442	508	508	564	694	822
	kg	200	230	230	256	315	373
<b>Boiler water content</b>	USG	9.2	11.6	11.6	12.7	16.1	19.3
	ltrs	35	44	44	48	61	73
<b>Max. operating pressure</b> <sup>*2</sup>	psig	30	30	30	30	30	30
	kPa	207	207	207	207	207	207
<b>Boiler water connections</b>							
Supply and return	inches	1½	1½	1½	2	2	2
Safety supply	inches	1½	1½	1½	2	2	2
Drain valve	inches	1½	1½	1½	2	2	2
<b>Gross flue gas temperature</b> <sup>*3</sup> at							
- 104°F / 40°C boiler water temperature	°F	311	311	311	311	311	311
	°C	155	155	155	155	155	155
- 167°F / 75°C boiler water temperature	°F	356	356	356	356	356	356
	°C	180	180	180	180	180	180
<b>Boiler vent connection</b> <sup>*4</sup>	outer Ø inches	5	5	5	6	6	6
<b>Required flue draft</b>	"w.c.	-0.02	-0.02	-0.02	-0.02	-0.02	-0.02

<sup>\*1</sup> Combustion results are based on 11.0% to 13.5% CO<sub>2</sub> with fuel oil #2 and a hot water heating system supply temperature of 167°F / 75°C, return 140°F / 60°C.

<sup>\*2</sup> Max. operating pressure is 45 psig / 310 kPa in all Canadian provinces where a CRN is **not required, and in the U.S.A.**

<sup>\*3</sup> Measured flue gas temperature with combustion air temperature of 68°F / 20°C.

<sup>\*4</sup> A 5" vent pipe adaptor is shipped with models VR1-22 to VR1-33. The vent pipe adaptor is not supplied with boiler models VR1-40 to VR1-63.

► For information regarding direct vent applications, please refer to Direct Vent Systems Installation Instruction Supplement.

► For information regarding other Viessmann System Technology componentry, please reference documentation of the respective product.

Vitorond 100 with Aquastat

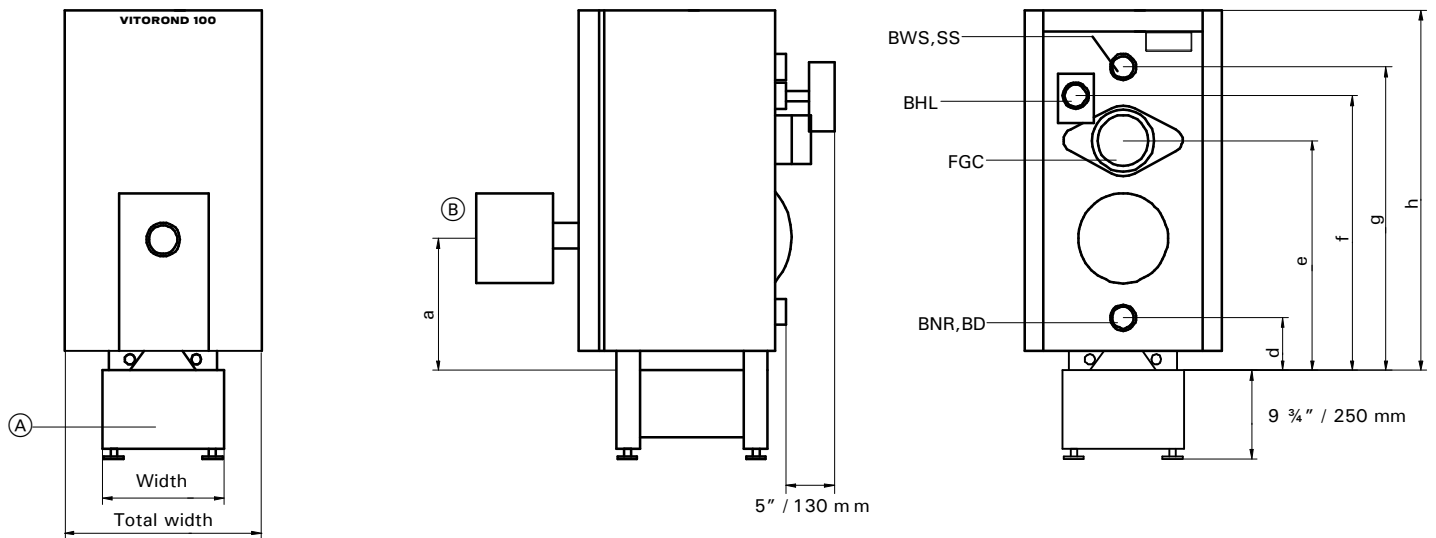

Fig. 1

Legend

- BD Boiler Drain
- BTS Boiler Temperature Sensor
- BWR Boiler Water Return
- BWS Boiler Water Supply
- FGC Flue Gas Collar
- SR Safety Return
- SS Safety Supply
- BHL Boiler High Limit (with outdoor reset module)

- (A) Boiler Stand
- (B) Beckett or Riello Burner

Vitorond 100 with Vitotronic Control

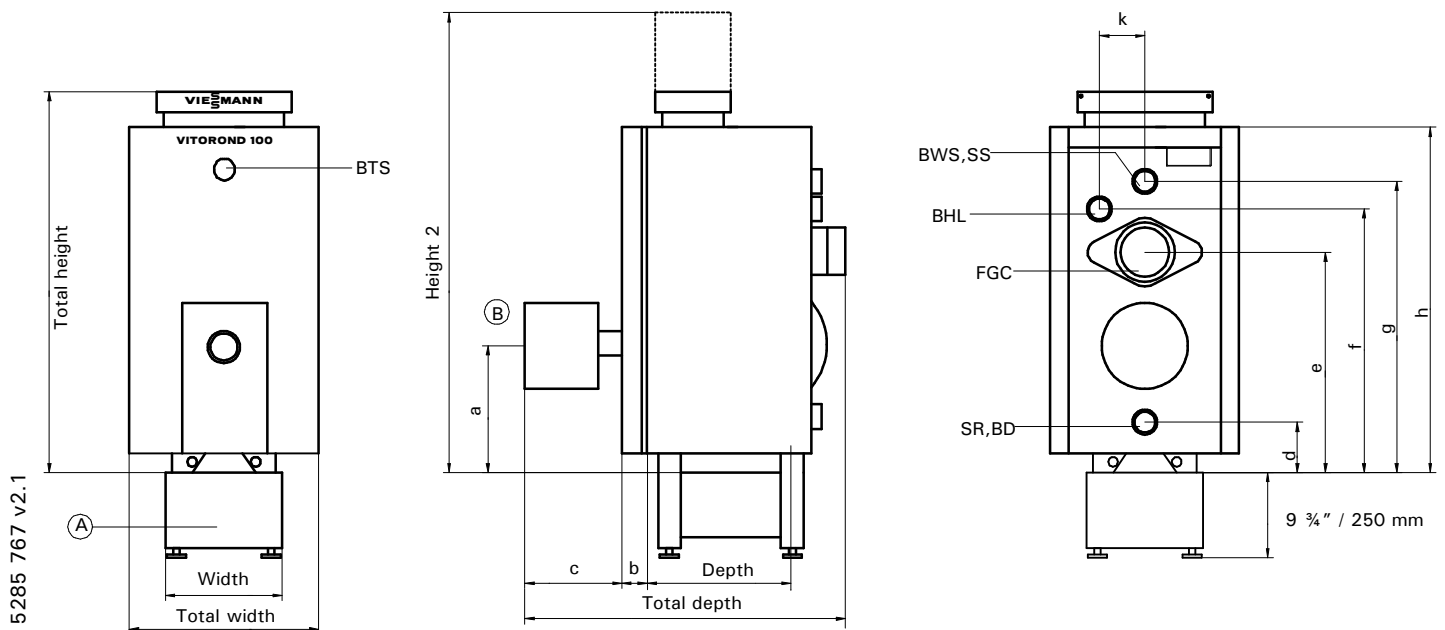

5285 767 v2.1

Fig. 2

## Technical Data

### Dimensions

Boiler Model	VR1	-22	-27	-33	-40	-50	-63
a	inch	13¼	13¼	13¼	13¼	13¼	13¼
	mm	338	338	338	347	347	347
b	inch	3	3	3	3	3	3
	mm	75	75	75	75	75	75
c	inch	12½	12½	12½	12½	9½	9½
	mm	312	312	312	312	247	247
d	inch	5½	5½	5½	4¼	4¼	4¼
	mm	137	137	137	107	107	107
e	inch	23	23	23	27¾	27¾	27¾
	mm	585	585	585	702	702	702
f	inch	26¼	26¼	26¼	32¼	32¼	32¼
	mm	667	667	667	822	822	822
g	inch	28½	28½	28½	34¾	34¾	34¾
	mm	726	726	726	882	882	882
h	inch	33	33	33	39¾	39¾	39¾
	mm	840	840	840	1010	1010	1010
k	inch	5½	5½	5½	6½	6½	6½
	mm	138	138	138	166	166	166

**Minimum Clearances to Combustibles**

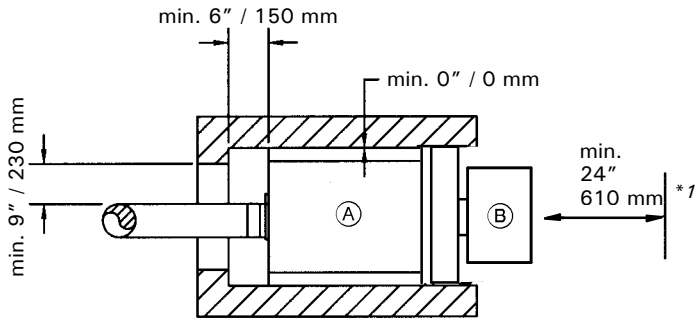

Fig. 3 Top view

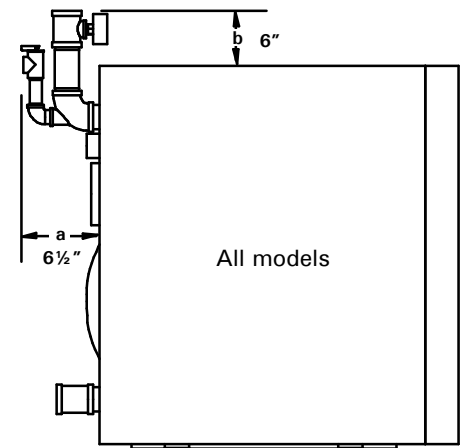

Fig. 5

- (A) Boiler
- (B) Burner - Riello or Beckett

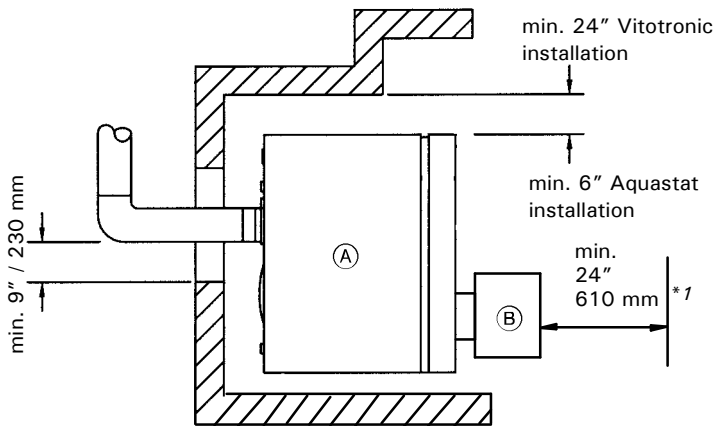

Fig. 4 Side view

**Standard installation**

Boiler Model	VR1	-22	-27	-33	-40	-50	-63
Rear	inches	6	6	6	6	6	6
Sides	mm	150	150	150	150	150	150
	inches	0	0	0	0	0	0
Flue	mm	0	0	0	0	0	0
	inches	9	9	9	9	9	9
	mm	230	230	230	230	230	230
Floor		Combustibles					

**Alcove installation**

Boiler Model	VR1	-22	-27	-33	-40	-50	-63
Rear	inches	6	6	6	6	6	6
Sides	mm	150	150	150	150	150	150
	inches	0	0	0	0	0	0
Flue	mm	0	0	0	0	0	0
	inches	9	9	9	9	9	9
Top*2	mm	230	230	230	230	230	230
	inches	6	6	6	6	6	6
	mm	150	150	150	150	150	150
Floor		Combustibles					

\*1 Front service clearance.

\*2 24" with Vitotronic control.

## Technical Data

### Beckett burner (chimney and direct vent\*1 application)

Boiler Model	Model No.	VR1-22*	VR1-27*	VR1-33*	VR1-40	VR1-50	VR1-63
Burner model	Beckett	NX-VI 501	NX-VI 502	NX-VI 503	NX-VI 504	AFG-VI 601	AFG-VI 601
Fuel type	oil	No. 2 fuel oil					
Pump pressure	psig kPa	190 1207	175 1207	175 1207	175 1207	175 1207	175 1207
Oil nozzle	Danfoss	n.a.	0.60x60°AS	n.a.	0.85x60°AH	n.a.	n.a.
	Delavan	0.50x60°B	n.a.	0.75x60°A/W	0.85x60°A	1.10x45°W	1.35x60°W
	Hago	0.50x60°B	0.60x60°B	n.a.	n.a.	1.10x45°W	1.35x60°B
Oil nozzle flow rate	GPH@psig	0.65@175	0.75@175	1.00@175	1.15@175	1.40@175	1.75@175
Air tube length	inches	7	7	7	7	9	9
	mm	178	178	178	178	230	230
Air tube insertion	inches	3¼	3¼	3 <sup>5</sup> / <sub>8</sub>	4 <sup>7</sup> / <sub>8</sub>	7¼	7¼
	mm	83	83	92	124	184	184

\*1 Direct vent burners available only for sizes VR1-22, -27, -33

► For information regarding direct vent applications, please refer to Direct Vent Systems Installation Instruction Supplement.

### Riello burner (chimney vent application)

Boiler Model	Model No.	VR1-22	VR1-27	VR1-33	VR1-40	VR1-50	VR1-63
Burner model	Riello 40 Series	F3	F3	F5	F5	F5	F10
Fuel type	oil	No. 2 fuel oil					
Pump pressure	psig kPa	175 1207	175 1207	175 1207	175 1207	175 1207	175 1207
Oil nozzle	Danfoss	0.50x60°AS	0.60x60°AS	0.75x60°AS	0.85x60°AH	1.10x60°AH	1.35x60°AH
	Delavan	0.50x60°SS	0.60x60°W	0.75x60°A 0.75x60°W	0.85x60°A 0.85x60°W	1.10x60°A	1.35x60°A 1.35x60°W
	Hago	0.50x60°SS	0.60x60°ES	n.a.	0.85x60°H	1.10x60°H 1.10x60°SS	1.35x45°SS
Oil nozzle flow rate	GPH@psig	0.65@175	0.75@175	1.00@175	1.15@175	1.40@175	1.75@175
Air tube length	inches	7	7	6 <sup>5</sup> / <sub>16</sub>	6 <sup>5</sup> / <sub>16</sub>	6 <sup>5</sup> / <sub>16</sub>	7
	mm	178	178	160	160	160	178
Air tube insertion	inches	4 <sup>5</sup> / <sub>8</sub>	4 <sup>5</sup> / <sub>8</sub>	4¼	4¼	4¼	4¼
	mm	118	118	108	108	108	121
Turbulator setting		0.0	2.0	0.8	1.0	3.0	2.0
Air gate setting		3.1	3.4	2.9	3.5	3.6	2.8

► Boiler standard working pressure: 30 psig; maximum working pressure: 45 psig.

► Wherever possible, vertically vent the boiler with a properly sized chimney which meets all local and national codes.

► Draft at the breech is typically -0.02 to -0.08 "w.c.



**Riello burner (direct vent application)**

<b>Boiler model</b>	Model No.	VR1-22	VR1-27 *1	VR1-33
<b>Burner model</b>	Riello 40 Series	BF3	BF3 *1	BF5
<b>Fuel type</b>	oil	No. 2 fuel oil		
<b>Pump pressure</b>	psig	175	175	140
<b>Oil nozzle</b>	Danfoss	n.a.	n.a.	n.a.
<b>Oil nozzle</b>	Delavan	0.5x60°SS	0.6x60°W *3	0.85x60°W *2
<b>Oil nozzle</b>	Hago	n.a.	n.a.	n.a.
<b>Oil nozzle flow rate</b>	GPH@psig	0.65@175	0.75@175	1.00@140
<b>Air tube length</b>	inches	7	7	6 <sup>5</sup> / <sub>16</sub>
	mm	178	178	160
<b>Air tube insertion</b>	inches	4 <sup>5</sup> / <sub>8</sub>	4 <sup>5</sup> / <sub>8</sub>	4 <sup>1</sup> / <sub>4</sub>
	mm	118	118	108
<b>Turbulator setting</b>		0.0	1.0	1.0
<b>Air gate setting</b>		3.7	5.0	4.0

**IMPORTANT**

\*1 For VR1-27 boiler, replace installed nozzle with nozzle packaged with Riello burner. Riello oil burners are factory set for Vitorond 100, VR1-22, and -33 boilers and should only require minor adjustments. Install appropriate nozzle and set the burner for model VR1-27.  
 \*2 Factory-installed nozzle.  
 \*3 Nozzles must be installed by installer.

**Standard Boiler Equipment**

*Note:*  
 Boiler with controls and burners are purchased separately. Please see Price List for details.

- Boiler shell (insulation preinstalled up to size VR1-33)
  - 30 psig pressure relief valve
  - Drain valve
- Installation fittings
  - Tridicator
  - Honeywell aquastat (with outdoor reset module)
- Beckett burner c/w Viessmann specified oil nozzle
  - Riello burner c/w Viessmann specified oil nozzle

The Boiler Stand must be ordered separately.

**Boiler Control Alternatives**

**Honeywell Aquastat Control**  
 High Limit  
 Model L7248C1006  
 (with outdoor reset module)

**Vitotronic 100, KW10B**  
 enhanced boiler control for modulating temperature heating systems with indoor/outdoor system control

**Vitotronic 200, KW2**  
 for multiple temperature heating systems with or without a mixing valve with indoor/outdoor digital boiler and heating system control

---

# System Design Considerations

## System Design Considerations

### Chimney

For proper operation of the Vitorond boiler, all products of combustion must be safely vented to the outdoors, while ensuring that flue gases do not cool prematurely.

It is critical that the chimney system be properly designed to handle the flue gas temperatures which the Vitorond boiler produces.

Flue gases which cool too quickly and produce condensation lead to damages if the chimney diameter is too large and the chimney system is not well insulated. If a calculated chimney diameter lies between two values, the larger diameter should be selected.

### Intermediate section

The intermediate (vertical and horizontal) section of venting between the boiler vent pipe collar and the chimney must be of the identical diameter as the vent connection of the boiler. Use the shortest possible path between the boiler and the chimney. A maximum of two elbows may be installed in the intermediate section. Avoid the use of two level 90° elbows.

The intermediate section must be sealed pressure tight at the boiler vent pipe collar and at the chimney connection. Ensure any test port for combustion values is sealed as well.

The chimney connection length between the boiler vent pipe collar and the chimney may be installed with insulation. We recommend consulting a reputable chimney installer for advice in project-specific circumstances. Barometric damper must be used!

**NOTE:** Direct Vent exhaust system operates under a positive pressure developed by the burner. Make sure all vent connections and observation ports on the boiler are sealed air tight by tightening screws and using high temperature silicone sealant if necessary.

The vent components must be supplied without any alteration except for the length of the flex pipe which can be cut to the desired length.

### Warranty

Our warranty does not cover damages resulting from the following:

- installation or service by unqualified and not licensed personnel
- corrosion caused by flue gas condensation due to low boiler water and/or return water temperatures
- operation with contaminated fill and supplementary feed water

For detailed warranty information, please read warranty sheet supplied with product.

### Combustion air supply

The boiler must not be located in areas or rooms where chemicals containing chlorine, bromine, fluorine, or other corrosive chemicals are stored. Examples include refrigerants, bleach, paint, paint thinner, hair spray, cleaning solvents, water softener salt, etc. The combustion air must not be contaminated with the above mentioned, or other aggressive or corrosive chemicals.

Boiler should never be installed in areas where excessive dust, high humidity, or risk of frost exist. Ensure adequate ventilation and supply of fresh combustion air.

Consult Viessmann with uncertainties in regard to a suitable boiler installation location.

This boiler/burner unit needs clean fresh air for safe operation and must be installed so that there are provisions for adequate combustion and ventilation air. For oil-fired boilers, use the "Installation Code for Oil Burning Equipment CAN/CSA-B139" (Canada), or NFPA 31 (USA) and/or provisions of local codes.

The sizing methods outlined in the above codes should be used when installing a round duct to supply combustion air from the outside. Observe local jurisdictional requirements.

### System layout

The boiler water temperature limit is factory set to 167°F / 75°C (Vitotronic only).

The boiler water temperature limit can be increased by altering the adjustable high limit to increase the supply water temperature.

To minimize piping losses of the system however, we recommend that the radiation and domestic hot water production in the system be designed for a 158°F / 70°C boiler supply water temperature (new systems).

### Water quality

Treatment for boiler feed water should be considered in areas of known problems, such as where a high mineral content and hardness exist. In areas where freezing might occur, an antifreeze may be added to the system water to protect the system. Please adhere to the specifications given by the antifreeze manufacturer. Do not use automotive silicate based antifreeze. Please observe that an antifreeze/water mixture may require a backflow preventer within the automatic water feed and influence components such as diaphragm expansion tanks, radiation, etc. A 40% antifreeze content will provide freeze-up protection to -10°F / -23°C. Do **not** use antifreeze other than specifically made for hot water heating systems. System also may contain components which might be negatively affected by antifreeze. Check total system frequently when filled with antifreeze. Advise system operator/ultimate owner that system is filled with a glycol mix.

The heating contractor must provide an MSDS (Material Safety Data Sheet) for the antifreeze used to the system operator/ultimate owner.

### Oxygen diffusion barrier underfloor tubing

The boiler warranty does not cover leaks resulting from corrosion caused by the use of underfloor plastic tubing without an oxygen diffusion barrier. Such systems must have the non-oxygen diffusion barrier tubing separated from the boiler with a heat exchanger. Viessmann recommends the use of underfloor plastic tubing with an oxygen diffusion barrier.

### Low water cut-off

A low water cut-off may be required by local codes. If boiler is installed above the radiation level, a low water cut-off device of approved type must be installed in all instances. An approved type low water cut-off device must be provided by the heating contractor. Do not install an isolation valve between the boiler and the low water cut-off.

**General**

The schematics on the following pages are to be seen as guidelines only. They further do not display all system varieties, safety devices, or concepts possible. Specific system layouts may be further discussed with the local Viessmann sales representative office.

**Clearances**

A minimum of 2" circumferential clearance from non-insulated hot water pipes to combustible construction must be maintained. In cases where the pipes are insulated with pipe insulation of appropriate and sufficient thickness and insulation values, the above clearance may be reduced to 0".

**Waterside flow**

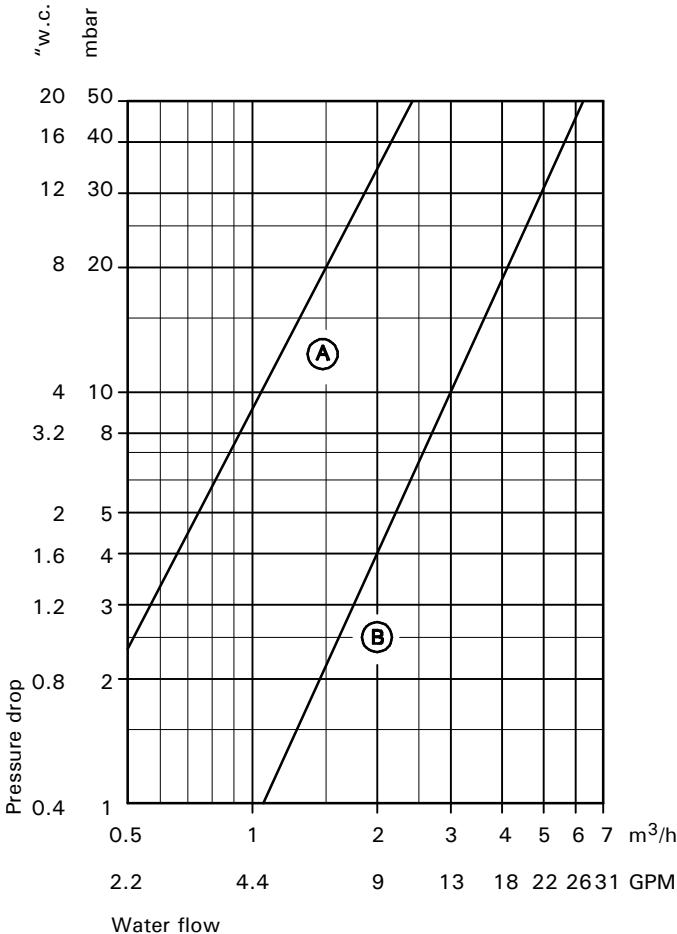

Fig. 6

- (A) VR1-22 to -33
- (B) VR1-40 to -63

**Flow rates**

The relationship between boiler flow rate and temperature rise is according to the formula:

$$\text{Boiler output (Btu/h)} = 500 \times \text{flow (USGPM)} \times \text{Rise (°F)}$$

The following chart lists typical flow rates for the Vitorond boiler:

Boiler Model	VR1	-22	-27	-33
20°F rise	USGPM	8	9.2	12.2
30°F rise	USGPM	5.3	6.1	8.1

Boiler Model	VR1	-40	-50	-63
20°F rise	USGPM	14	17.2	21.5
	m³/h	3.2	3.9	4.9
30°F rise	USGPM	9.3	11.5	14.3
	m³/h	2.1	2.6	3.2

Boiler in a heating/cooling application

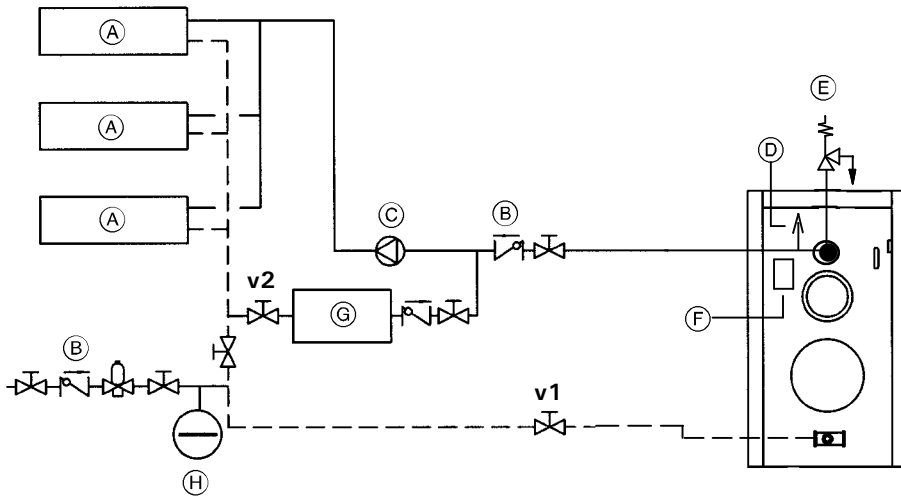

**Cooling season starts:**  
close valve v1 and open valve v2

**Heating season starts:**  
close valve v2 and open valve v1

- (A) Heating/Cooling unit
- (B) Spring-loaded flow check valve
- (C) Circulation pump
- (D) Automatic air vent,
- (E) Pressure relief valve
- (F) High limit control
- (G) Water chiller
- (H) Expansion tank

Fig. 7

**IMPORTANT**

We strongly suggest that the valves pictured above be labelled "v1" and v2."

Low water cut-off

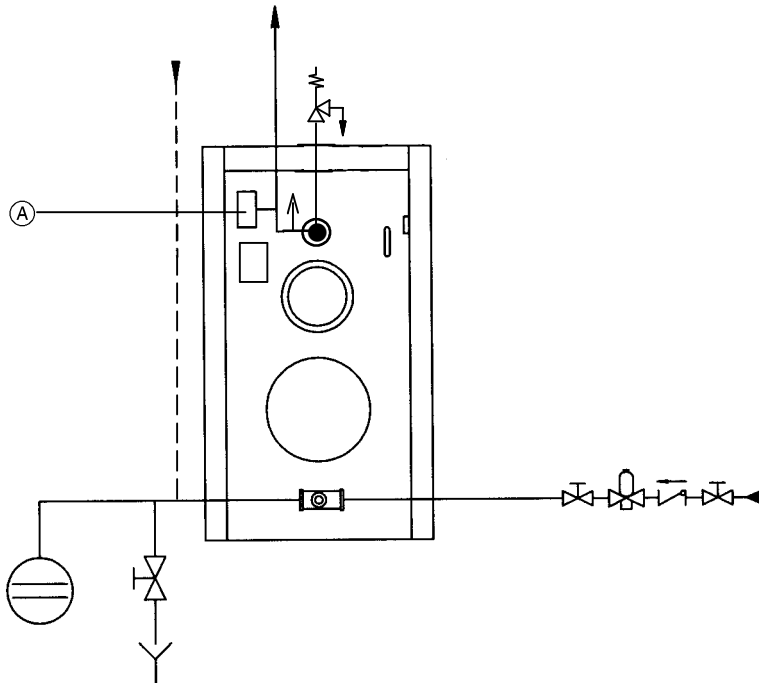

A low water cut-off may be required by local codes. If boiler is installed above radiation level, a low water cut-off device (A) of approved type (field supplied) must be installed in all instances. Do **not** install an isolation valve between boiler and low water cut-off.

Fig. 8

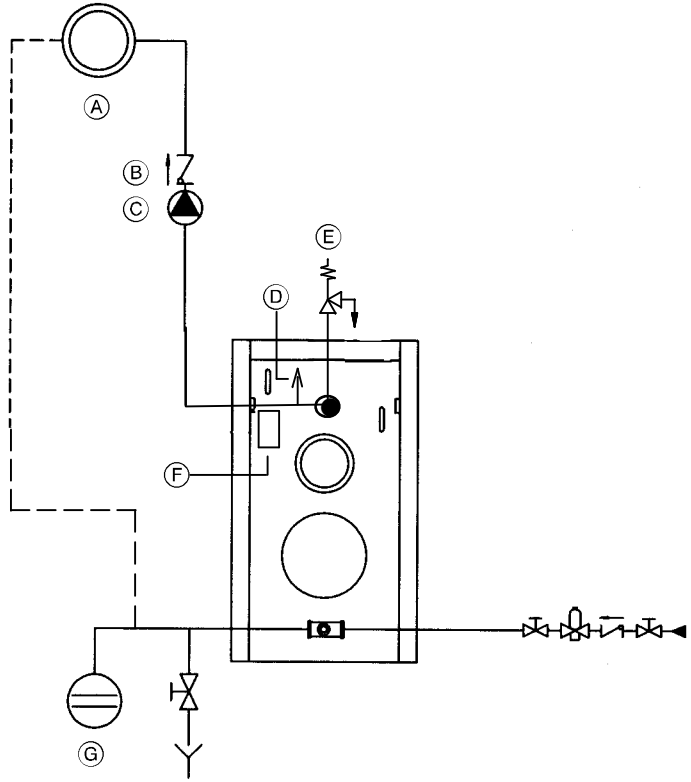

- Ⓐ Heating circuit
- Ⓑ Spring-loaded flow check valve
- Ⓒ Circulation pump
- Ⓓ Automatic air vent
- Ⓔ Pressure relief valve
- Ⓕ High limit control
- Ⓖ Expansion tank

Fig. 9

# Installation Examples - Vitotronic

## Without mixing valve

e.g. with Vitotronic 100, Model KW10B

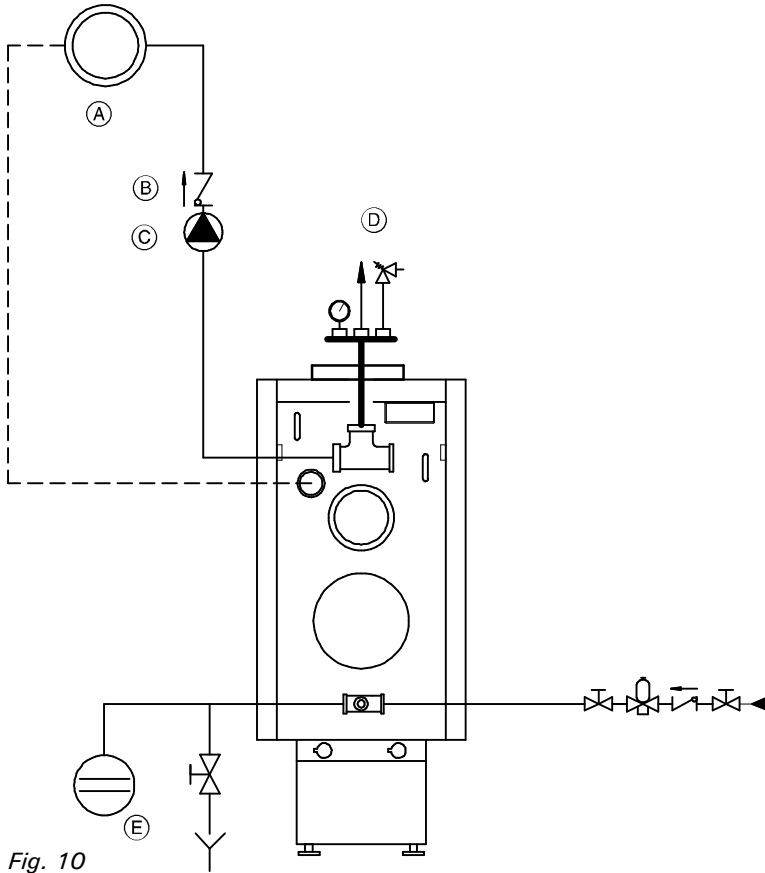

- (A) Heating circuit
- (B) Spring-loaded flow check valve
- (C) Circulation pump
- (D) Automatic air vent (field supplied), pressure relief valve, and temperature pressure gage
- (E) Expansion tank

Fig. 10

## Without mixing valve and with DHW

e.g. with Vitotronic 100, KW10B

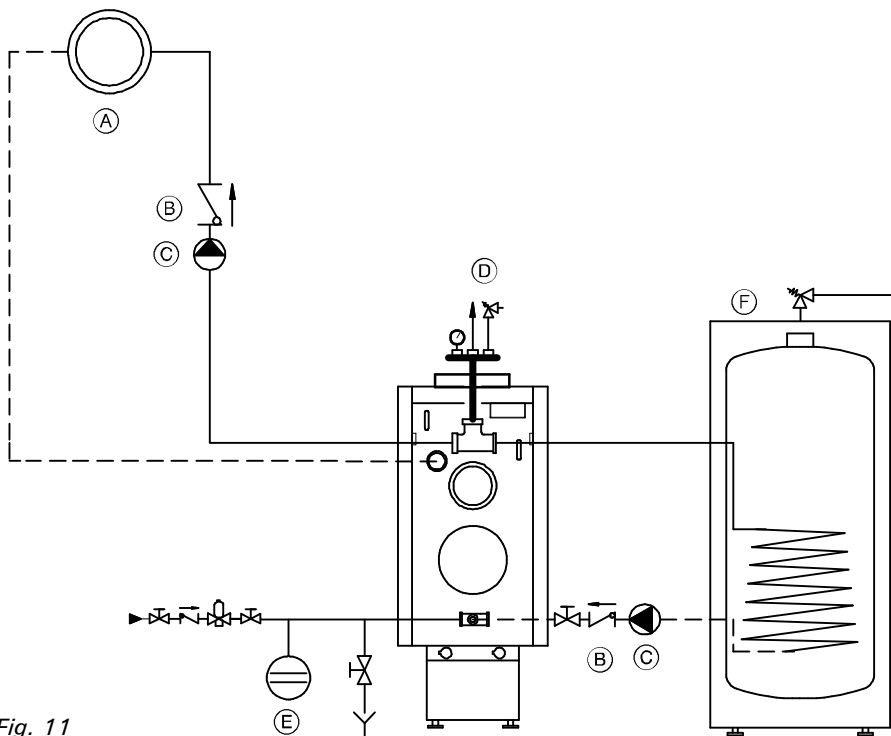

- (A) Heating circuit
- (B) Spring-loaded flow check valve
- (C) Circulation pump
- (D) Automatic air vent (field supplied), pressure relief valve, and temperature pressure gage
- (E) Expansion tank
- (F) Domestic hot water storage tank (indirect-fired)

Fig. 11

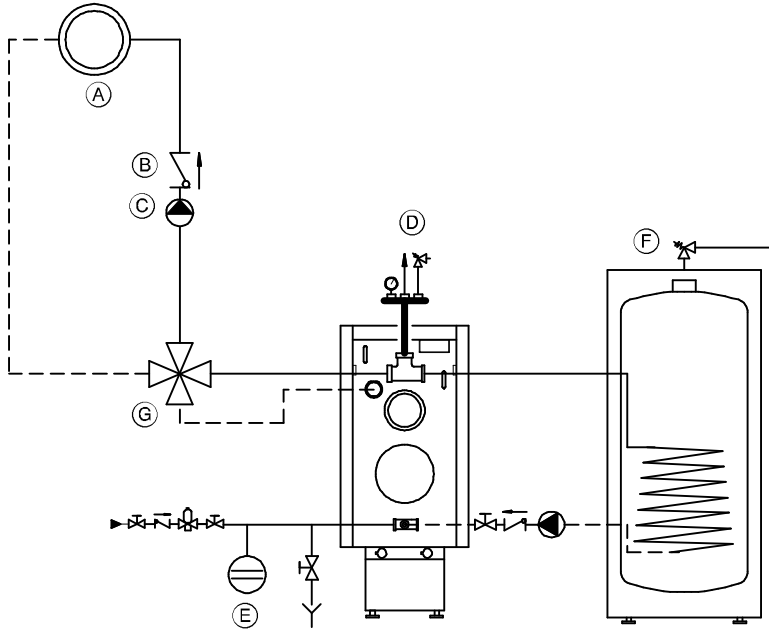

**With one low-temperature circuit with 4-way mixing valve, and with domestic hot water production**  
 e.g. with Vitotronic 200, Model KW2  
 combined with one Mixing Valve Actuator Accessory Kit

- (A) Heating circuit
- (B) Spring-loaded flow check valve
- (C) Circulation pump
- (D) Automatic air vent (field supplied), pressure relief valve, and temperature pressure gage
- (E) Expansion tank
- (F) Domestic hot water storage tank (indirect-fired)
- (G) 4-Way mixing valve

Fig. 12

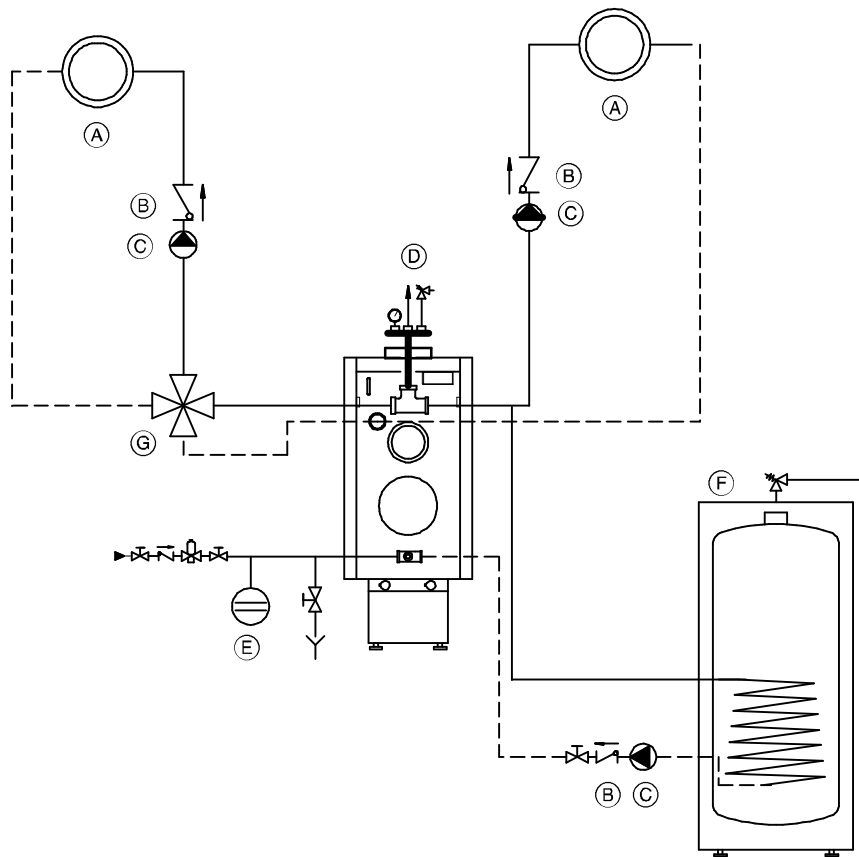

**With one low-temperature circuit with 4-way mixing valve, and one high temperature circuit, and with domestic hot water production**  
 e.g. with Vitotronic 200, Model KW2  
 combined with one Mixing Valve Actuator Accessory Kit

- (A) Heating circuit
- (B) Spring-loaded flow check valve
- (C) Circulation pump
- (D) Automatic air vent (field supplied), pressure relief valve, and temperature pressure gage
- (E) Expansion tank
- (F) Domestic hot water storage tank (indirect-fired)
- (G) 4-Way mixing valve

5285 767 v2.1

Fig. 13

Viessmann Manufacturing Company Inc.  
750 McMurray Road  
Waterloo, Ontario • N2V 2G5 • Canada  
**Technfo Line 1-888-484-8643**  
1-800-387-7373 • Fax (519) 885-0887  
[www.viessmann.ca](http://www.viessmann.ca) • [info@viessmann.ca](mailto:info@viessmann.ca)

Viessmann Manufacturing Company (U.S.) Inc.  
45 Access Road  
Warwick, Rhode Island • 02886 • USA  
**Technfo Line 1-888-484-8643**  
1-800-288-0667 • Fax (401) 732-0590  
[www.viessmann-us.com](http://www.viessmann-us.com) • [info@viessmann-us.com](mailto:info@viessmann-us.com)

