

THIS SPACE FOR DESIGNER/ENGINEER APPROVAL

Job/Customer _____	Date _____	Contractor _____
Model Specified _____	Qty _____	Approved By _____
Designer/Engineer _____	Date _____	Contractor's PO# _____
Submitted By _____	Date _____	Other _____

Hydro-Core Manifolds

Flange Right

600 WOG

ISO 9001



ITEM#	CTN/CASE	RUN A	VALVE	DRAIN	UNION B	FLANGE C	HOSE D	E	F	G	H	I	J
FIP													
48754-0	1/6	1 1/4"	1	1/2	1	1	3/4	8 7/8	7 1/2	4	5 3/8	6 3/16	3 3/4
48764-0	1/6	1 1/2"	1	1/2	1	1	3/4	8 7/8	7 1/2	4	5 1/2	6 3/16	3 3/4
48755-0	1/6	1 1/4"	1 1/4	3/4	1 1/4	1 1/4	3/4	10	8 1/4	4 3/8	6	6 3/8	4 1/8
48765-0	1/6	1 1/2"	1 1/4	3/4	1 1/4	1 1/4	3/4	10	8 1/4	4 3/8	6	6 3/8	4 1/8
48766-0	1/4	1 1/2"	1 1/2	3/4	1 1/2	1 1/2	3/4	10 7/8	8 1/4	5	6 3/8	7 1/2	4 1/8
SWT													
58744-0	1/6	1"	1	1/2	1	1	3/4	9	7 1/2	4	5 1/2	6 3/16	3 3/4
58754-0	1/6	1 1/4"	1	1/2	1	1	3/4	8 7/8	7 1/2	4	5 1/4	6 3/16	3 3/4
58764-0	1/6	1 1/2"	1	1/2	1	1	3/4	8 7/8	7 1/2	4	5 7/16	6 3/16	3 3/4
58774-0	1/4	2"	1	1/2	1	1	3/4	9	8	4	5 7/8	6 3/16	3 3/4
58755-0	1/6	1 1/4"	1 1/4	3/4	1 1/4	1 1/4	3/4	10	8 1/4	4 3/8	5 3/4	6 3/8	4 1/8
58765-0	1/6	1 1/2"	1 1/4	3/4	1 1/4	1 1/4	3/4	10	8 1/4	4 3/8	5 7/8	6 3/8	4 1/8
58775-0	1/4	2"	1 1/4	3/4	1 1/4	1 1/4	3/4	10	8 5/8	4 3/8	6 3/8	6 3/8	4 1/8
58766-0	1/4	1 1/2"	1 1/2	3/4	1 1/2	1 1/2	3/4	10 7/8	8 1/4	5	6 1/4	7 1/2	4 1/8
58776-0	1/4	2"	1 1/2	3/4	1 1/2	1 1/2	3/4	10 7/8	8 5/8	5	6 3/4	7 1/2	4 1/8

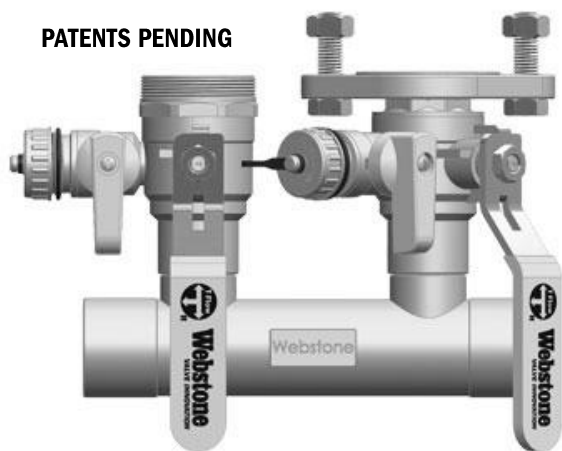

PATENTS PENDING

TEMP	WOG
100	600
150	485
200	395
250	210
300	N/A
350	N/A
366	N/A

FLANGE DIMENSIONS

FLANGE C	KA	KB	KC	KD
1"	1/2	2 11/16	4 3/16	2 1/4
1 1/4"	5/8	2 11/16	4 3/16	2 1/4
1 1/2"	5/8	2 11/16	4 3/16	2 1/4

NO	Description	Material
1	Body	Brass
2	Flange End Cap	Brass
3	Union Cap	Brass
4	Seat	PTFE
5	Ball	Brass HCP
6	Stem	Brass
7	Stem Seal	PTFE
8	Packing Gland	Brass
9	Lever Handle	Stainless Steel
10	Handle Jacket	Vinyl
11	Handle Nut	Stainless Steel
12	Seat	PTFE
13	Ball	Brass HCP
14	Stem	Brass
15	Stem Seal	PTFE
16	Packing Gland	Brass
17	Handle	Aluminum
18	Handle Screw	Brass
19	End Cap	Brass
20	Washer	EPDM
21	Cap And Strap	Brass w/ EPDM Strap
22	Flange Ring	Brass
23	Flange	Brass
24	Nut	Stainless Steel
25	Bolt	Stainless Steel



Quality and Commitment Since 1954

www.webstonevalves.com · P: (800) 225-9529 · F: (800) 336-5133

Webstone product specifications in U.S. customary units are approximate and are provided for reference only. Webstone reserves the right to change or modify product design, construction, specifications or materials without prior notice and without incurring any obligation to make such changes and modifications on Webstone products previously or subsequently sold.

Hydro-CoreRightspec_050811

THIS SPACE FOR DESIGNER/ENGINEER APPROVAL

Job/Customer _____	Date _____	Contractor _____
Model Specified _____	Qty _____	Approved By _____
Designer/Engineer _____	Date _____	Contractor's PO# _____
Submitted By _____	Date _____	Other _____

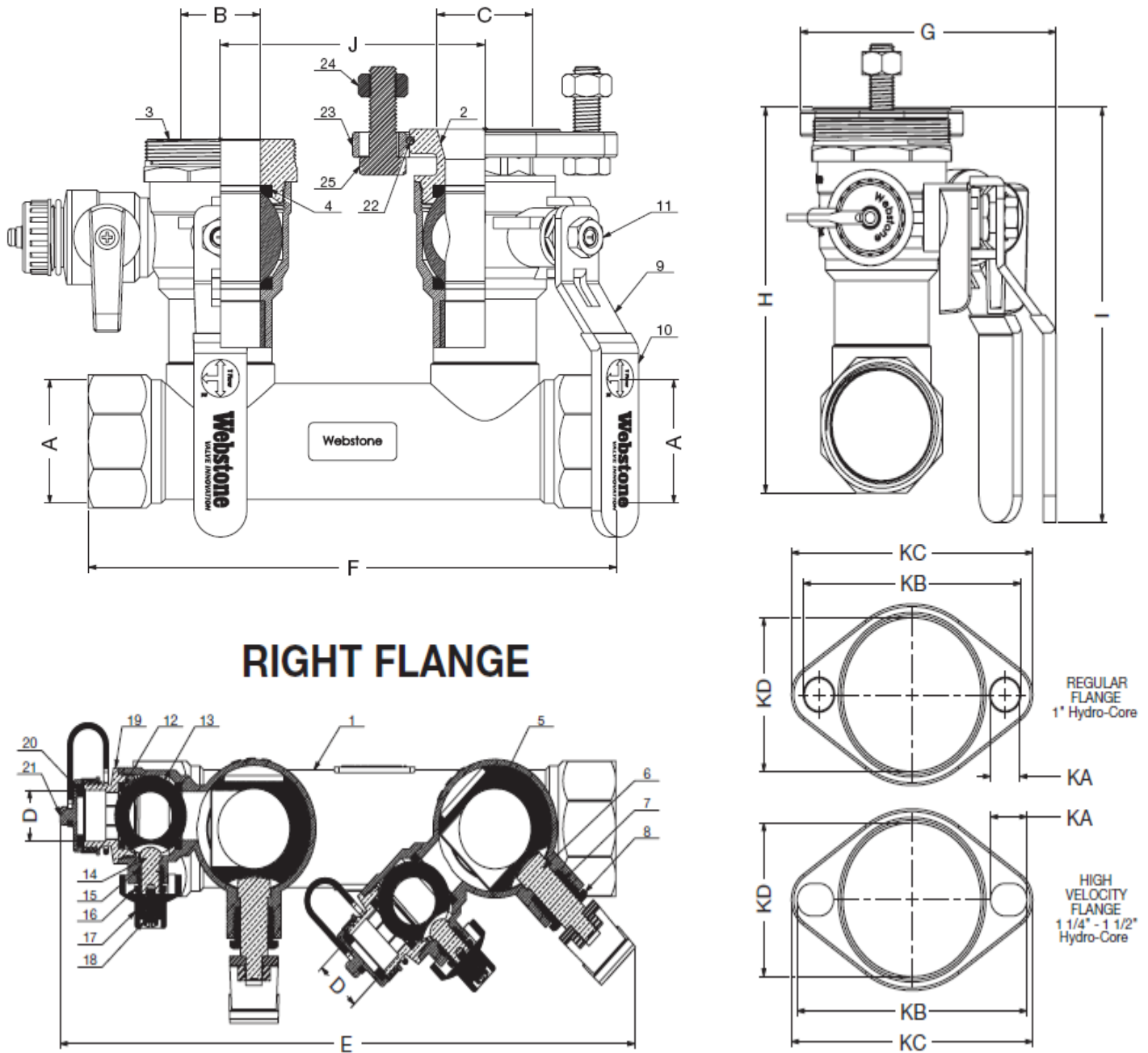

Specifications: Designed for residential, commercial or industrial use with water or a glycol mixture in a closed loop Hydronic system. This approved Webstone valve assembly design can be used in both near boiler piping applications as well as secondary circuit loops and is actuated by blowout proof stems and feature adjustable packing glands. Threaded ends comply with ANSI B1.20.1. Solder joint temperature ratings are per ASME B16.18 Annex A for 95-5 solder. Other solder materials have lower pressure/temperature limits. Do not silver braze or overheat valves when soldering.



Quality and Commitment Since 1954

www.webstonevalves.com · P: (800) 225-9529 · F: (800) 336-5133

Webstone product specifications in U.S. customary units are approximate and are provided for reference only. Webstone reserves the right to change or modify product design, construction, specifications or materials without prior notice and without incurring any obligation to make such changes and modifications on Webstone products previously or subsequently sold.

Hydro-CoreRightspec_050811