

SPIROCOMBI MAGNET

The Ultimate Air & Dirt Separator
Now with magnets and universal connection



Industry-leading
20-year guarantee

SPIROCOMBI MAGNET

Eliminates air and protects
pumps, valves, boilers and heat
exchangers from dirt and debris



Eliminates 100% of the free air,
100% of the entrained air, and
up to 99.6% of the dissolved air
in the system



Separates dirt particles and
ferrous material using powerful
magnets around flowpath

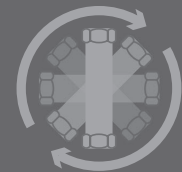

Horizontal or vertical
pipe installation (360°)

Available in sizes:
3/4", 1", 1 1/4", 1 1/2", 2"

Threaded, Sweat and Pressfit

For information and availability:
www.spirotherm.com

SPIROCOMBI MAGNET



SPECIFICATIONS

- Brass body
- Brass vent head
- Non-ferrous float
- Viton seal
- Viton O-ring
- Engineered Spirotube® coalescing media
- Neodymium magnets
- 150 psig maximum working pressure
- 270°F maximum operating temperature
- Blowdown valve included



Model	NPT	VDR075FTM	VDR100FTM	VDR125FTM	VDR150FTM	VDR200FTM
	Sweat	VDR075SWM	VDR100SWM	VDR125SWM	VDR150SWM	VDR200SWM
	Pressfit	VDR075PFM	VDR100PFM	VDR125PFM	VDR150PFM	VDR200PFM
d	Pipe Size	3/4	1	1 1/4	1 1/2	2
H	inches	10.7	10.7	16	16	16
h1	inches	5.9	5.9	9.1	9.1	9.1
D	inches	3.3	3.3	3.3	3.3	3.3
b	inches	4.9	5.1	5.4	5.6	5.8
L	NPT	inches	3.9	3.9	5.0	5.0
L	Sweat	inches	3.9	3.9	6.1	6.1
L	Pressfit	inches	6.5	6.7	8.3	9.3
Weight	(lbs)	6	6.5	11.5	11.5	12.5
Rec. Flow	(GPM)	6	10	15	30	40

dimensions for reference only

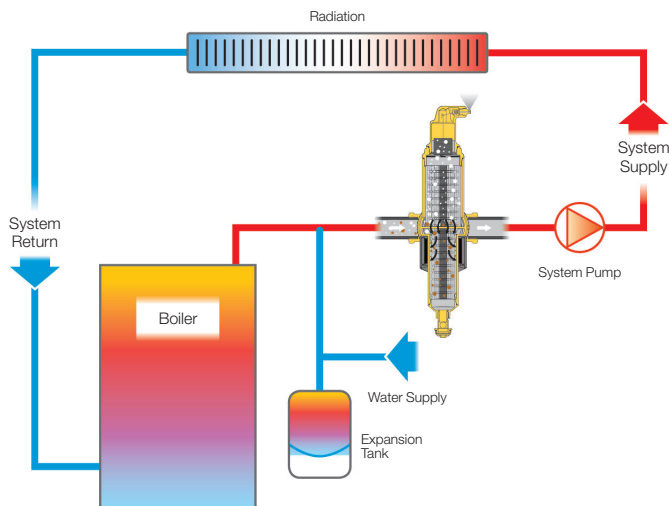
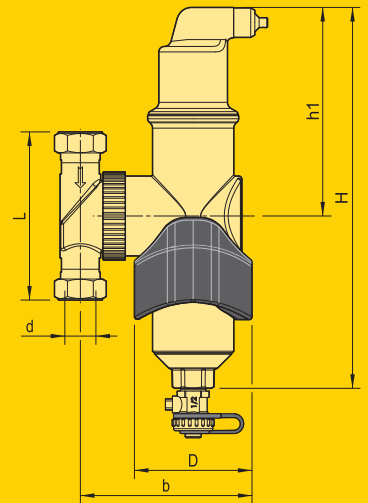

Universal connection accommodates any pipe direction

